



Product specification

Articulated robot

IRB 6600 - 175/2.55
IRB 6600 - 225/2.55
IRB 6600 - 175/2.8
IRB 6650 - 125/3.2
IRB 6650 - 200/2.75
IRB 6650S - 125/3.5
IRB 6650S - 200/3.0
IRB 6600ID - 185/2.55
IRB 6650ID - 170/2.75
M2004



Product Specification

Articulated robot

3HAC 023933-001

Rev.1

IRB 6600 - 175/2.55

IRB 6600 - 225/2.55

IRB 6600 - 175/2.8

IRB 6650 - 125/3.2

IRB 6650 - 200/2.75

IRB 6650S - 125/3.5

IRB 6650S - 200/3.0

IRB 6600ID - 185/2.55

IRB 6650ID - 170/2.75

M2004

The information in this manual is subject to change without notice and should not be construed as a commitment by ABB. ABB assumes no responsibility for any errors that may appear in this manual.

Except as may be expressly stated anywhere in this manual, nothing herein shall be construed as any kind of guarantee or warranty by ABB for losses, damages to persons or property, fitness for a specific purpose or the like.

In no event shall ABB be liable for incidental or consequential damages arising from use of this manual and products described herein.

This manual and parts thereof must not be reproduced or copied without ABB's written permission, and contents thereof must not be imparted to a third party nor be used for any unauthorized purpose. Contravention will be prosecuted.

Additional copies of this manual may be obtained from ABB at its then current charge.

©Copyright 2004 ABB All right reserved.

ABB Automation Technologies AB
Robotics
SE-721 68 Västerås
Sweden

1 Description	5
1.1 Structure	5
1.1.1 Introduction	5
1.1.2 Different robot versions	6
1.1.3 Definition of version designation	7
1.2 Safety/Standards	10
1.2.1 Standards	10
1.2.2 The Active Safety System	11
1.2.3 The Passive Safety System	13
1.2.4 The Internal Safety Concept	14
1.3 Installation	16
1.3.1 Introduction	16
1.3.2 Operating requirements	17
1.3.3 Mounting the manipulator	18
1.4 Calibration and references	23
1.4.1 Fine calibration	23
1.4.2 Absolute Accuracy calibration	24
1.4.3 Robot references	26
1.5 Load diagrams	29
1.5.1 Introduction	29
1.5.2 Diagrams	30
1.5.3 Maximum load and moment of inertia for full and limited axis 5 (center line down) movement	44
1.5.4 Mounting equipment	46
1.5.5 Mounting of hip load	48
1.6 Maintenance and Troubleshooting	54
1.6.1 Introduction	54
1.7 Robot Motion	55
1.7.1 Introduction	55
1.7.2 Performance according to ISO 9283	61
1.7.3 Velocity	62
1.8 Cooling fan for axis 1-3 motor	63
1.8.1 Introduction	63
1.9 Servo Gun	64
1.9.1 Introduction	64
1.9.2 Stationary Gun	65
1.9.3 Robot Gun	66
1.9.4 Stationary and Robot Gun	67
1.9.5 Twin Stationary Guns	68
1.9.6 Stationary Gun and Track Motion	69
1.9.7 Robot Gun and Track Motion	70
1.9.8 Track Motion	71
2 SpotPack and DressPack	73
2.1 Introduction	73
2.1.1 General	73
2.1.2 Chapter Structure	75
2.2 DressPack	76
2.2.1 Introduction	76
2.3 Type H	84
2.3.1 Introduction	84
2.3.2 Configuration result for Type H	87

Table of Contents

2.3.3 Interface description DressPack for Type H	91
2.3.4 Summary Type H	95
2.4 Type S	96
2.4.1 Introduction	96
2.4.2 Configuration result for Type S	99
2.4.3 Interface description DressPack for Type S	103
2.4.4 Summary Type S	110
2.5 Type HS	111
2.5.1 Introduction	111
2.5.2 Configuration result for Type HS	114
2.5.3 Interface description DressPack for Type HS	118
2.5.4 Interface description stationary gun	125
2.5.5 Summary Type HS	127
2.6 Type Se	128
2.6.1 Introduction	128
2.6.2 Configuration result for Type Se	131
2.6.3 Interface description DressPack for Type Se	135
2.6.4 Summary Type Se	143
2.7 Type HSe	144
2.7.1 Introduction	144
2.7.2 Configuration result for Type HSe	147
2.7.3 Interface description DressPack for Type HSe	151
2.7.4 Interface description stationary gun	158
2.7.5 Summary Type HSe	161
2.8 SpotWelding cabinet	162
2.8.1 Introduction	162
2.8.2 Interface description SpotWelding cabinet	170
2.9 Water and Air unit	171
2.9.1 Introduction	171
2.9.2 Interface description Water and Air unit	178
2.10 Connection kits	179
2.10.1 Options	179
3 Specification of Variants and Options	183
3.1 Introduction	183
3.1.1 General	183
3.1.2 Manipulator	183
3.1.3 Equipment	184
3.1.4 Position Switches	187
3.1.5 Floor cables	189
3.1.6 Process DressPack	190
3.1.7 DressPack Floor	190
3.1.8 DressPack Lower and Upper arm	191
3.1.9 Connection Kits	192
3.1.10 Servo Gun	193
3.1.11 SpotPack Floor Cables	194
3.1.12 SpotPack Equipment	195
3.1.13 Documentation	196
4 Accessories	197

1 Description

1.1 Structure

1.1.1 Introduction

Robot family

A new world of possibilities opens up with ABB's IRB 6600 robot family. It comes in nine versions, 175kg /2.55m, 225kg /2.55m, 175kg /2.8m, 125kg/3.2m, 125kg/3.5m, 200kg/2.75m, 200 kg/3.0m , 185kg/2.55m and 170kg/2.75m handling capacities.

The IRB 6600 is ideal for process applications, regardless of industry. Typical areas can be SpotWelding, Material Handling and machine tending.

Software product range

We have added a range of software products - all falling under the umbrella designation of Active Safety - to protect not only personnel in the unlikely event of an accident, but also robot tools, peripheral equipment and the robot itself.

Operating system

The robot is equipped with the operating system BaseWare OS. BaseWare OS controls every aspect of the robot, like motion control, development and execution of application programs, communication etc. See Product Specification IRC5.

Additional functionality

For additional functionality, the robot can be equipped with optional software for application support - for example spot welding, communication features - network communication - and advanced functions such as multi-tasking, sensor control, etc. For a complete description on optional software, see the Product Specification RobotWare Options.

1 Description

1.1.2 Different robot versions

Illustration

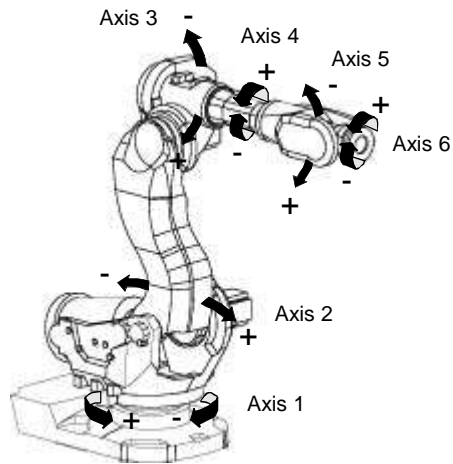

Figure 1 The IRB 6600 manipulator has 6 axes.

1.1.2 Different robot versions

General

The IRB 6600 is available in nine versions.

Standard

The following different standard robot types are available:

Robot type	Handling capacity	Reach (m)
IRB 6600	175 kg	2.55 m
IRB 6600	225 kg	2.55 m
IRB 6600	175 kg	2.8 m
IRB 6650	125 kg	3.2 m
IRB 6650	200 kg	2.75 m
IRB 6650S	125 kg	3.5 m
IRB 6650S	200 kg	3.0 m
IRB 6600ID	185 kg	2.55 m
IRB 6650ID	170 kg	2.75 m

1.1.3 Definition of version designation

IRB 6600 Mounting

Handling capacity (kg)/ Reach (m)

	Prefix	Description
Mounting	-	Floor-mounted manipulator
Handling capacity (kg)	yyy	Indicates the maximum handling capacity (kg)
Reach (m)	x.x	Indicates the maximum Reach (m) at wrist center (m)

Manipulator weight

Robot type	Handling capacity (kg)	Reach (m)	Weight
IRB 6600	175 kg	2.55 m	1700 kg ¹
IRB 6600	225 kg	2.55 m	1780 kg ¹
IRB 6600	175 kg	2.8 m	1780 kg ¹
IRB 6650	125 kg	3.2 m	1780 kg ¹
IRB 6650	200 kg	2.75 m	1780 kg ¹
IRB 6650S	125 kg	3.5 m	2250 kg ¹
IRB 6650S	200 kg	3.0 m	2250 kg ¹
IRB 6600ID	185 kg	2.55 m	1880 kg
IRB 6650ID	170 kg	2.75 m	1880 kg

1. Without DressPack

Other technical data

Data	Description	Note
Airborne noise level	The sound pressure level outside the working space	< 73 dB (A) Leq (acc. to Machinery directive 98/37/EEC)

Power consumption at max load

Type of Movement	IRB 6600/ 6650 IRB 6600ID/ IRB 6650ID	IRB 6650S
ISO Cube	2.6 kW	2.4 KW
Normal robot movements	3.8 kW	-

1 Description

1.1.3 Definition of version designation

Illustration

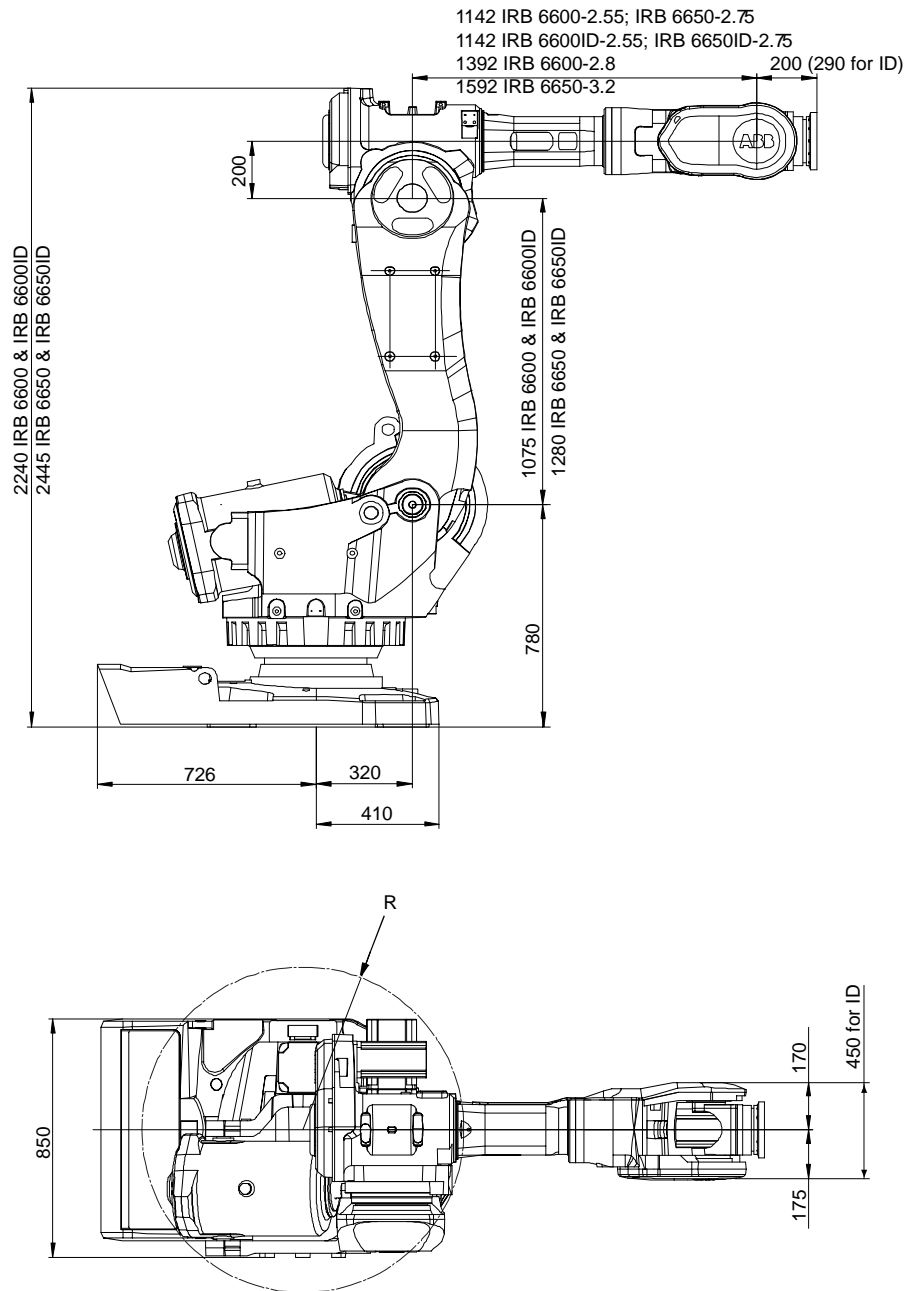

Figure 2 View of the IRB 6600 and IRB 6650 manipulator from the side and above (dimensions in mm). Allow 200 mm behind the manipulator foot for cables.

Pos	Description
R	R 580 for type A. R 595 for type B (front side, motor axis Z). R690 with fork lift.

For DressPack dimensions see chapter 2.2 DressPack



Illustration

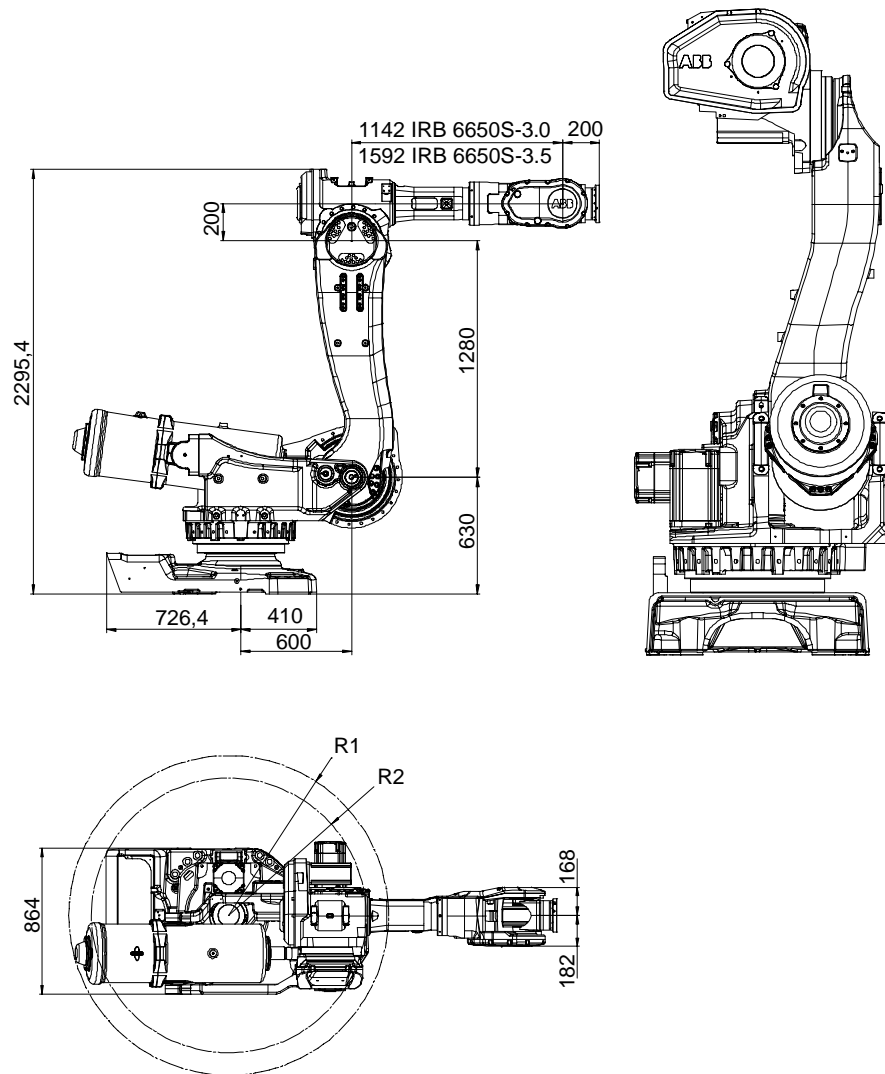

Figure 3 View of the IRB 6650S Manipulator from side and above (dimensions in mm). Allow 200 mm behind the manipulator foot for cables.

Pos	Description
R1	R 946 (Rear side, Balancing device).
R2	R 813 (Front side, Motor axis 2).

1 Description

1.2.1 Standards

1.2 Safety/Standards

1.2.1 Standards

The robot conforms to the following standards:

Standard	Description
EN ISO 12100 -1	Safety of machinery, terminology
EN ISO 12100 -2	Safety of machinery, technical specifications
EN 954-1	Safety of machinery, safety related parts of control systems
EN 60204	Electrical equipment of industrial machines
EN 775	Electrical equipment of industrial machines
EN 61000-6-4 (option)	EMC, Generic emission
EN 61000-6-2	EMC, Generic immunity

Standard	Description
IEC 60204-1	Electrical equipment of industrial machines
IEC 60529	Degrees of protection provided by enclosures

Standard	Description
ISO 10218	Manipulating industrial robots, safety
ISO 9787	Manipulating industrial robots, coordinate systems and motions

Standard	Description
ANSI/RIA 15.06/1999	Safety Requirements for Industrial Robots and Robot Systems.
ANSI/UL 1740-1998 (option)	Safety Standard for Robots and Robotic Equipment
CAN/CSA Z 434-03 (option)	Industrial Robots and Robot Systems - General Safety Requirements

The robot complies fully with the health and safety standards specified in the EEC's Machinery Directives.

The Service Information System (SIS)

The service information system gathers information about the robot's usage and determines how hard the robot is used. The usage is characterised by the speed, the rotation angles and the load of every axis.

With this data collection, the service interval of every individual robot of this generation can be predicted, optimizing and planning ahead service activities. The collection data is available via the teach pendant or the network link to the robot.

The Process Robot Generation is designed with absolute safety in mind. It is dedicated to actively or passively avoid collisions and offers the highest level of safety to

the operators and the machines as well as the surrounding and attached equipment. These features are presented in the active and passive safety system.

The time the robot is in operation (brakes released) is indicated on the FlexPendant. Data can also be monitored over network, using e.g. WebWare.

1.2.2 The Active Safety System

General

The active safety system includes those software features that maintain the accuracy of the robot's path and those that actively avoid collisions which can occur if the robot leaves the programmed path accidentally or if an obstacle is put into the robot's path.

The Active Brake System (ABS)

All robots are delivered with an active brake system that supports the robots to maintain the programmed path in General Stop (GS), Auto Stop (AS) and Superior Stop (SS).

The ABS is active during all stop modes, braking the robot to a stop with the power of the servo drive system along the programmed path. After a specific time the mechanical brakes are activated ensuring a safe stop.

The stopping process is in accordance with a class 1 stop. The maximal applicable torque on the most loaded axis determines the stopping distance.

In case of a failure of the drive system or a power interruption, a class 0 stop turns out. Emergency Stop (ES) is a class 0 stop. All stops (GS, AS, SS and ES) are reconfigurable.

While programming the robot in manual mode, the enabling device has a class 0 stop.

The Self Tuning Performance (STP)

The Process Robot Generation is designed to run at different load configurations, many of which occur within the same program and cycle.

The robot's installed electrical power can thus be exploited to lift heavy loads, create a high axis force or accelerate quickly without changing the configuration of the robot.

Consequently the robot can run in a "power mode" or a "speed mode" which can be measured in the respective cycle time of one and the same program but with different tool loads. This feature is based on QuickMove™.

1 Description

1.2.2 The Active Safety System

The respective change in cycle time can be measured by running the robot in NoMotionExecution with different loads or with simulation tools like RobotStudio.

The Electronically Stabilised Path (ESP)

The load and inertia of the tool have a significant effect on the path performance of a robot. The Process Robot Generation is equipped with a system to electronically stabilize the robot's path in order to achieve the best path performance.

This has an influence while accelerating and braking and consequently stabilizes the path during all motion operations with a compromise of the best cycle time. This feature is secured through TrueMove™.

Over-speed protection

The speed of the robot is monitored by two independent computers.

Restricting the working space

The movement of each axis can be restricted using software limits.

As options there are safeguarded space stops for connection of position switches to restrict the working space for the axes 1-3.

Axes 1-3 can also be restricted by means of mechanical stops.

Collision detection (option)

In case of an unexpected mechanical disturbance, such as a collision, electrode sticking, etc., the robot will detect the collision, stop on the path and slightly back off from its stop position, releasing tension in the tool.

1.2.3 The Passive Safety System

General

The Process Robot Generation has a dedicated passive safety system that by hardware construction and dedicated solutions is designed to avoid collisions with surrounding equipment. It integrates the robot system into the surrounding equipment safely.

Compact robot arm design

The shape of the lower and upper arm system is compact, avoiding interference into the working envelope of the robot.

The lower arm is shaped inward, giving more space under the upper arm to re-orientate large parts and leaving more working space while Reach (m)ing over equipment in front of the robot.

The rear side of the upper arm is compact, with no components projecting over the edge of the robot base even when the robot is moved into the home position.

Moveable mechanical limitation of main axes (option)

All main axes can be equipped with moveable mechanical stops, limiting the working range of every axis individually. The mechanical stops are designed to withstand a collision even under full load.

Position switches on main axes (option)

All main axes can be equipped with position switches. The double circuitry to the cam switches is designed to offer personal safety according to the respective standards.

1 Description

1.2.4 The Internal Safety Concept

1.2.4 The Internal Safety Concept

General

The internal safety concept of the Process Robot Generation is based on a two-channel circuit that is monitored continuously. If any component fails, the electrical power supplied to the motors shuts off and the brakes engage.

Safety category 3

Malfunction of a single component, such as a sticking relay, will be detected at the next MOTOR OFF/MOTOR ON operation. MOTOR ON is then prevented and the faulty section is indicated. This complies with category 3 of EN 954-1, Safety of machinery - safety related parts of control systems - Part 1.

Selecting the operating mode

The robot can be operated either manually or automatically. In manual mode, the robot can only be operated via the teach pendant, i.e. not by any external equipment.

Reduced speed

In manual mode, the speed is limited to a maximum of 250 mm/s (600 inch/min.). The speed limitation applies not only to the TCP (Tool Center Point), but to all parts of the robot. It is also possible to monitor the speed of equipment mounted on the robot.

Three position enabling device

The enabling device on the teach pendant must be used to move the robot when in manual mode. The enabling device consists of a switch with three positions, meaning that all robot movements stop when either the enabling device is pushed fully in, or when it is released completely. This makes the robot safer to operate.

Safe manual movement

The robot is moved using a joystick instead of the operator having to look at the teach pendant to find the right key.

Emergency stop

There is one emergency stop push button on the controller and another on the teach pendant. Additional emergency stop buttons can be connected to the robot's safety chain circuit.

Safeguarded space stop

The robot has a number of electrical inputs which can be used to connect external safety equipment, such as safety gates and light curtains. This allows the robot's safety functions to be activated both by peripheral equipment and by the robot itself.

Delayed safeguarded space stop

A delayed stop gives a smooth stop. The robot stops in the same way as at a normal program stop with no deviation from the programmed path. After approx. 1 second the power supplied to the motors is shut off.

Hold-to-run control

“Hold-to-run” means that you must depress the start button in order to move the robot. When the button is released the robot will stop. The hold-to-run function makes program testing safer.

Fire safety

Both the manipulator and control system comply with UL's (Underwriters Laboratories Inc.) tough requirements for fire safety.

Safety lamp (option)

As an option, the robot can be equipped with a safety lamp mounted on the manipulator. This is activated when the motors are in the MOTORS ON state.

1 Description

1.3.1 Introduction

1.3 Installation

1.3.1 Introduction

General

All versions of IRB 6600 are designed for floor mounting. Depending on the robot version, an end effector with max. weight of 125 to 225 kg including payload, can be mounted on the mounting flange (axis 6). See Load diagram for IRB 6600 generation robots on 1.5.2 Diagrams.

Extra Loads

Extra loads (valve packages, transformers) can be mounted on the upper arm with a maximum weight of 50 kg. An extra load of 500 kg can also be mounted on the frame of axis 1. See Holes for mounting extra equipment on IRB 6600/6650 and IRB 6600ID/6650ID . No extra loads for IRB 6600ID/6650ID.

Working Range

The working range of axes 1-3 can be limited by mechanical stops. Position switches can be supplied on axes 1-3 for position indication of the manipulator.

External Mains Transformer

For mains voltage 200V and 220V an external transformer will be included.

1.3.2 Operating requirements

Protection standards

Standard and Foundry Manipulator IP67

Cleanroom standards

Cleanroom class 100 for manipulator according to:

Standards	Description
DIN EN ISO 14644	Cleanrooms and associated controlled environments
US Federal Standard 209	e-Air-clean-classes

Explosive environments

The robot must not be located or operated in an explosive environment.

Ambient temperature

Description	Standard/Option	Temperature
Manipulator during operation	Standard	+5°C (41°F) to +50°C (122°F)
For the controller	Standard	+5°C (41°F) to +45°C (113°F)
For the controller	Option	+5°C (41°F) to +52°C (126°F)
Complete robot during transportation and storage	Standard	-25°C (-13°F) to +55°C (131°F)
For short periods (not exceeding 24 hours)	Standard	up to +70°C (158°F)

Relative humidity

Description	Relative humidity
Complete robot during transportation and storage	Max. 95% at constant temperature
Complete robot during operation	Max. 95% at constant temperature

1 Description

1.3.3 Mounting the manipulator

1.3.3 Mounting the manipulator

Maximum Load

Maximum load in relation to the base coordinate system.

	Endurance load in operation all IRB 6600/ 6650/ 6600ID/ 6650ID	Max. load at emergency stop all IRB 6600/ 6650/ 6600ID/ 6650ID
Force xy	± 10.1 kN	± 20.7 kN
Force z	18.0 ±13.8 kN	18.0 ± 22.4 kN
Torque xy	± 27.6 kNm	± 50.6 kNm
Torque z	± 7.4 kNm	± 14.4 kNm

	Endurance load in operation IRB 6650S	Max. load at emergency stop IRB 6650S
Force xy	± 10.6kN	± 20.9 kN
Force z	28.2 ± 7.7kN	28.2 ± 16.4 kN
Torque xy	28.2 kN	50.5 kNm
Torque z	7.9 kN	13.6 kNm



When using Base spacers (opt. 571-1) the Torque xz on the floor is for IRB 6600/6650/6600ID/6650ID, 30,4 kNm and for IRB 6650S, 31 kNm for Endurance load in operation and for IRB 6600/6650/6600ID/6650ID, 55,7 kNm and for IRB 6650S, 55,6 kNm for Max. load at emergency stop. The other values above are the same as without Base spacers.

Fastening holes robot base

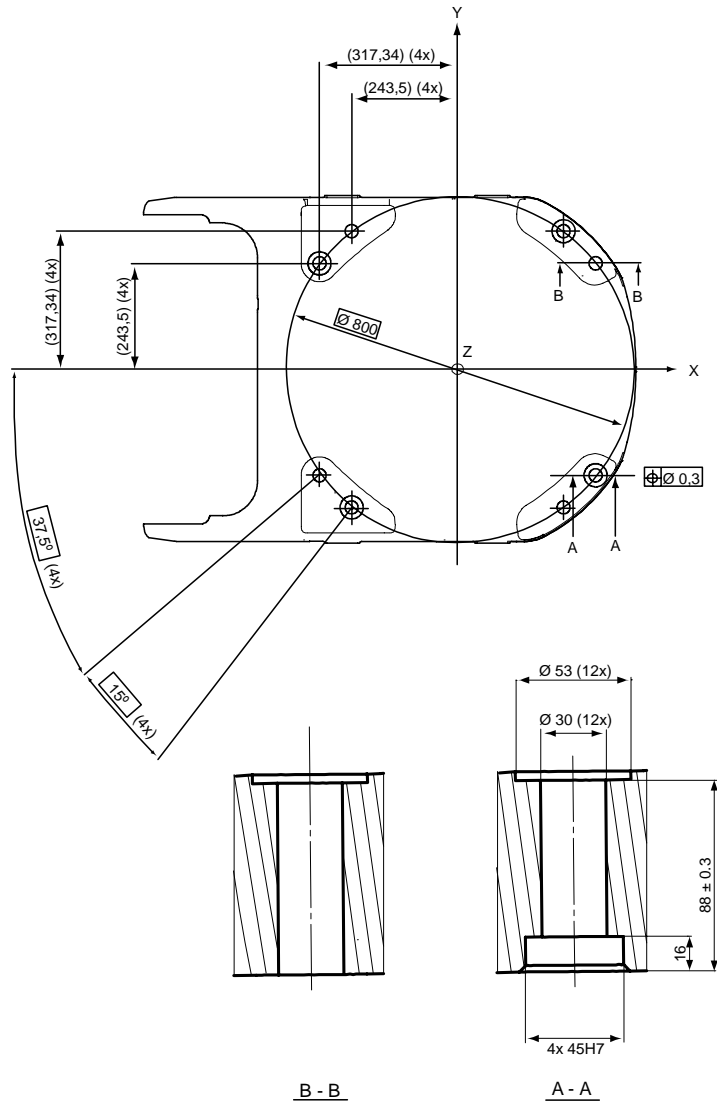

Figure 4 Hole configuration (dimensions in mm).

Recommended screws for fastening the manipulator to a base plate:

M24 x 140 8.8 with 4 mm flat washer. Torque value 775 Nm.



Only two guiding pins shall be used. The corresponding holes in the base plate shall be circular and oval according to Figure 5 and Figure 8.

Regarding AbsAcc performance, the chosen guide holes according to Figure 5 and Figure 8 are recommended.

1 Description

1.3.3 Mounting the manipulator

Base plate drawing

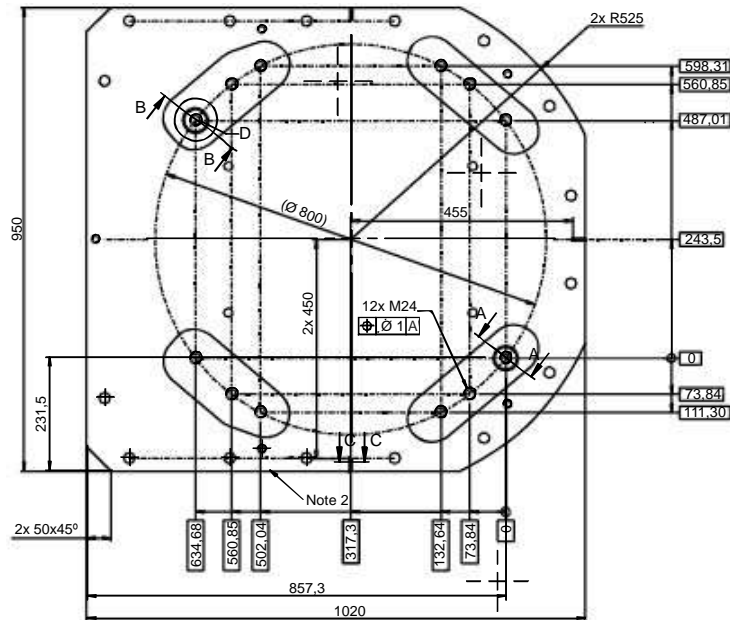
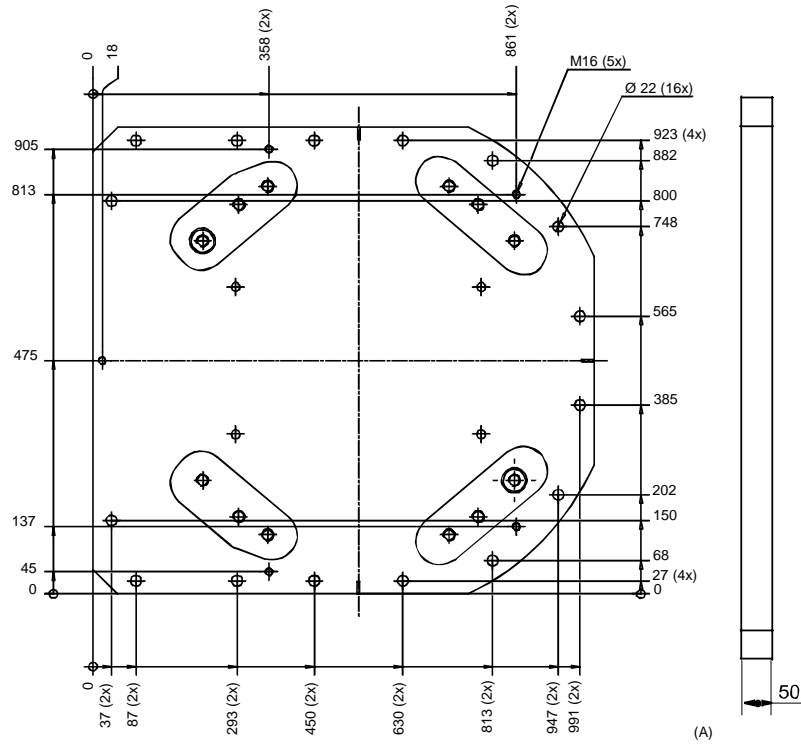

Figure 5 Option Base plate (dimensions in mm).

Pos	Description
A	Color: RAL 9005 Thickness: 80 - 100 µm

Illustration

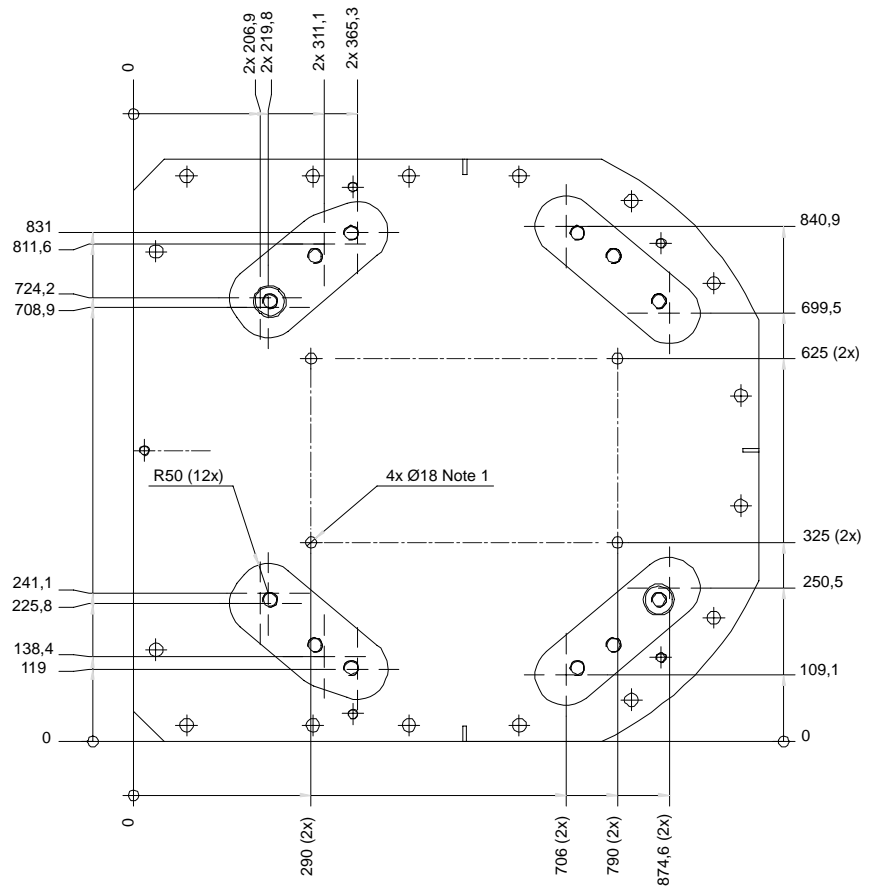

Figure 6 Option Base plate (dimension in mm).

1 Description

1.3.3 Mounting the manipulator

Two guiding sleeves required, dimensions see Figure 7

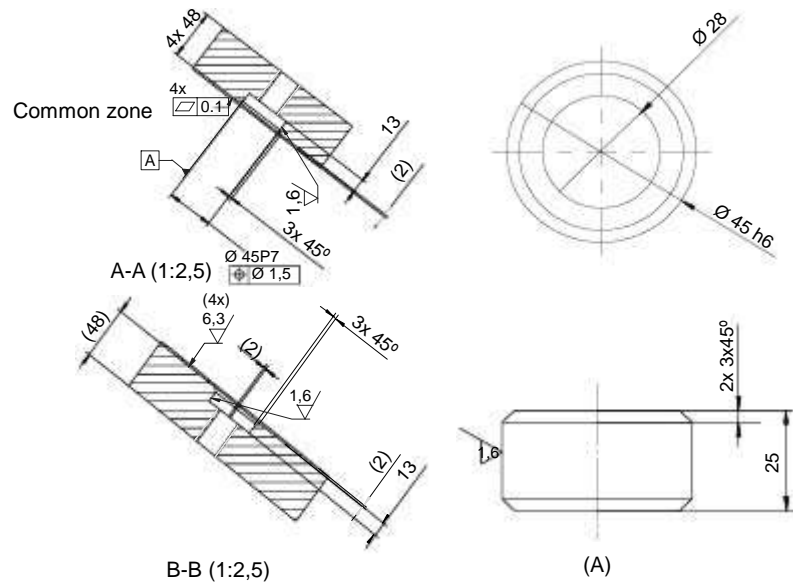

Figure 7 Sections of base plate and guide sleeve (dimensions in mm).

Pos	Description
A	Guide sleeve protected from corrosion

Illustration

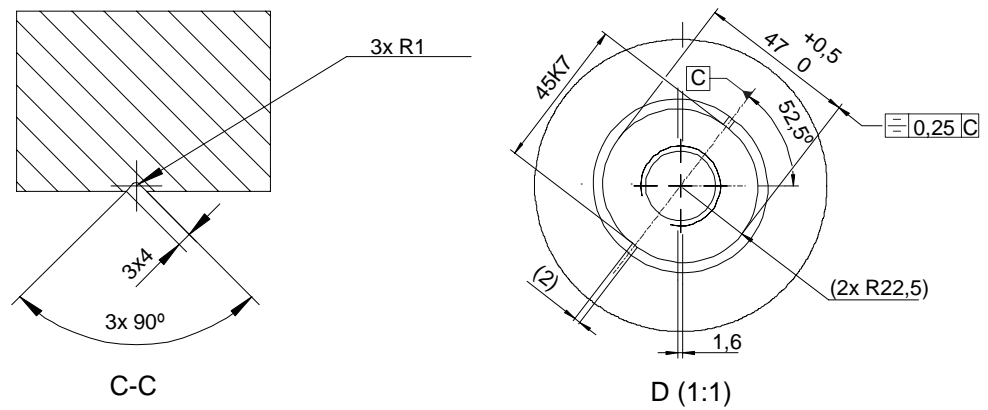

Figure 8 Sections of base plate (dimensions in mm).

1.4 Calibration and references

1.4.1 Fine calibration

General

Fine calibration is made using the Calibration Pendulum, please see separate manual Calibration Pendulum instruction.

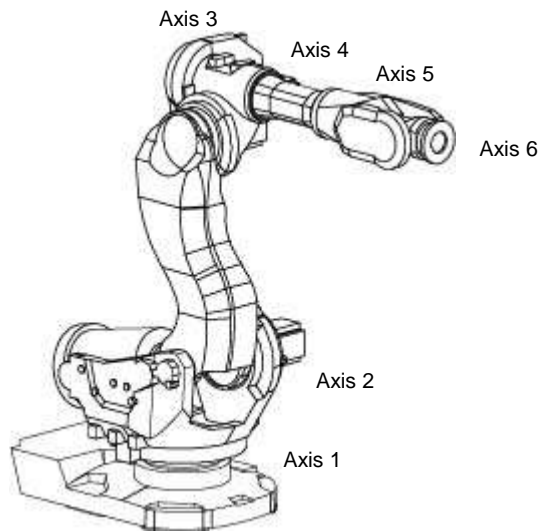

Figure 9 All axes in zero position.

Calibration

Calibration	Position
Calibration of all axes	All axes are in zero position
Calibration of axis 1 and 2	Axis 1 and 2 in zero position
	Axis 3 to 6 in any position
Calibration of axis 1	Axis 1 in zero position
	Axis 2 to 6 in any position

1 Description

1.4.2 Absolute Accuracy calibration

1.4.2 Absolute Accuracy calibration

General

Requires RobotWare option Absolute Accuracy, please see Product Specification RobotWare for more details.

The calibration concept

Absolute Accuracy (AbsAcc) is a calibration concept, which ensures a TCP absolute accuracy of better than ± 1 mm in the entire working range (working range of bending backward robots, eg IRB 6600, are limited to only forward positions).

Absolute accuracy compensates for:

- Mechanical tolerances in the robot structure
- Deflection due to load

Absolute accuracy calibration is focusing on positioning accuracy in the cartesian coordinate system for the robot. It also includes load compensation for deflection caused by the tool and equipment. Tool data from robot program is used for this purpose. The positioning will be within specified performance regardless of load.

Calibration data

The user is supplied with robot calibration data (compensation parameter file, absacc.cfg) and a certificate that shows the performance (Birth certificate). The difference between an ideal robot and a real robot without AbsAcc can be typically 8 mm, resulting from mechanical tolerances and deflection in the robot structure.

Absolute Accuracy option

Absolute Accuracy option is integrated in the controller algorithms for compensation of this difference and does not need external equipment or calculation.

Absolute Accuracy is a RobotWare option and includes an individual calibration of the robot (mechanical arm).

Absolute Accuracy is a TCP calibration in order to Reach (m) a good positioning in the Cartesian coordinate system.

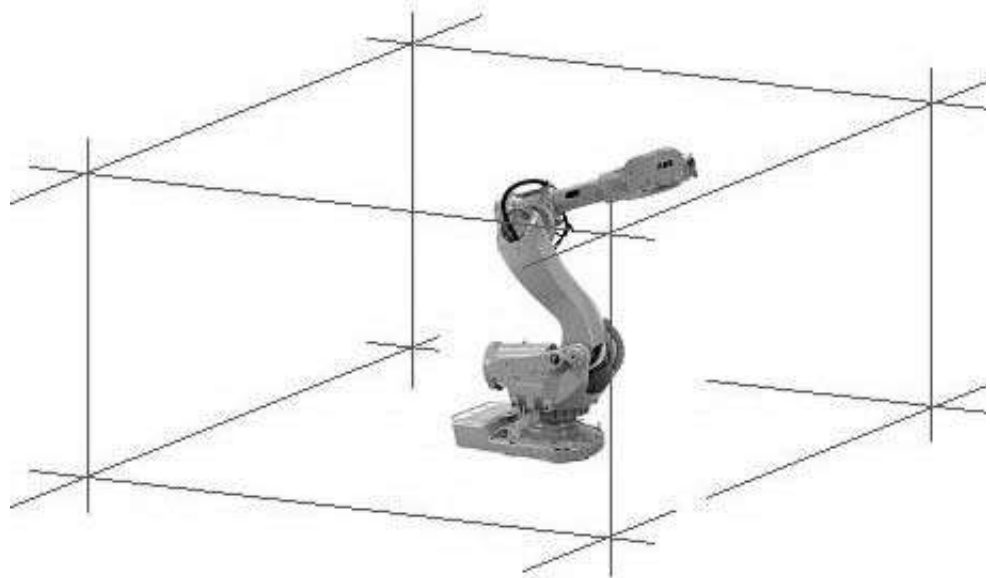

Figure 10 The Cartesian coordinate system

Production data

Typical production data regarding calibration are:

Robot	Positioning accuracy (mm)		
	Average	Max	% Within 1 mm
IRB 6600 - 175/2.55 225/2.55 175/2.80 125/3.20 200/2.75	0,50	1,20	97
IRB 6650 - 125/3.20 200/2.75	0,50	1,20	97
IRB 6650S - 125/3.50 200/3.00	0,50	1,20	97
IRB 6600ID - 185/2.55 IRB 6650ID - 170/2.75	*)	*)	*)

*) For detailed data and data missing in the table, please contact ABB for more information.

1 Description

1.4.3 Robot references

1.4.3 Robot references

General

The holes shown in Figure 11 to Figure 16 are used for measuring the robot position when integrated in a production cell.



Figure 11 Four $\varnothing 12$ H8 (depth 12) on radius 400 mm from axis 1 center on robot base.



Figure 12 One $\varnothing 12$ H8 (depth 12) in +x- direction from axis 1 center of robot base.

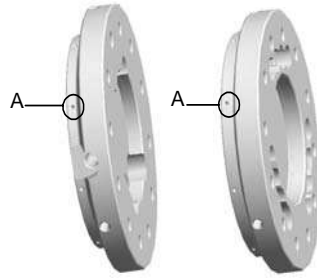

Figure 13 Seven holes A, on a radius of x mm from axis 6 center on the two standard tool flanges.

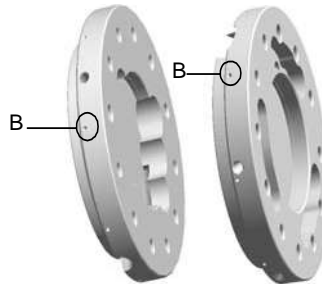

Figure 14 Seven holes B, on a radius of x mm from axis 6 center on the two insulated tool flanges.

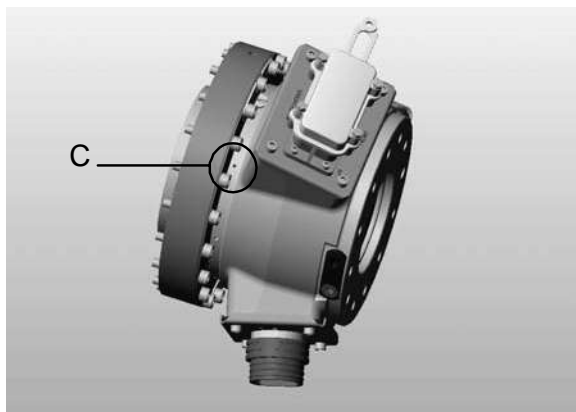

Figure 15 Seven holes C, on a radius of x mm from axis 6 center on the flange for IRB 6600ID/IRB 6650ID.

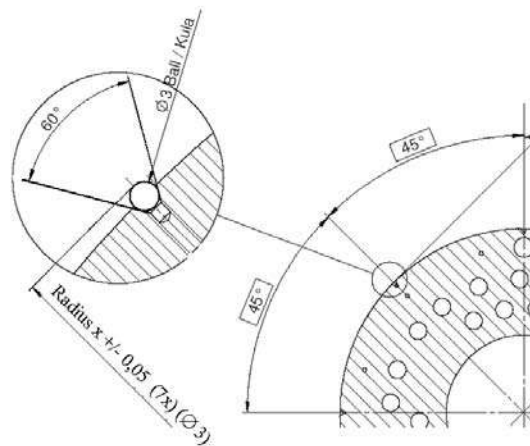

Figure 16 Detailed view of Tool Flange.

1 Description

1.4.3 Robot references

Robot	Radius X (mm) for references on tool flange	
	Standard	Insulated
IRB 6600 - 175/2.55	R=81,5	R=101,5
IRB 6600 -225/2.55 175/2.80 125/3.20 200/2.75	R=87,5	R=101,5
IRB 6650 - 125/3.20 200/2.75	R=87,5	R=101,5
IRB 6650S - 125/3.50 200/3.00	R=87,5	R=101,5
IRB 6600ID - 185/2.55 IRB 6650ID - 170/2.75	R=87,5	-

1.5 Load diagrams

1.5.1 Introduction

General

The load diagrams include a nominal payload inertia, J_0 of 15 kgm², and an extra load of 50 kg at the upper arm housing, see Figure 17.

At different arm load, payload and moment of inertia, the load diagram will be changed.

Accurate Load Diagram

For an accurate load diagram, please use one of the calculation programs, ABB RobotLoad IRB 6600/7600, the Excel application or the Stand alone application on:

- inside.abb.com/atma, click on Products --> Robots --> IRB 6600/7600 or
- <http://www.abb.com/roboticspartner>, click on Product range --> Robots --> IRB 6600/7600.

The Stand alone application, which is more complete, requires Microsoft.NET Framework and Microsoft Excel 9.0 software.

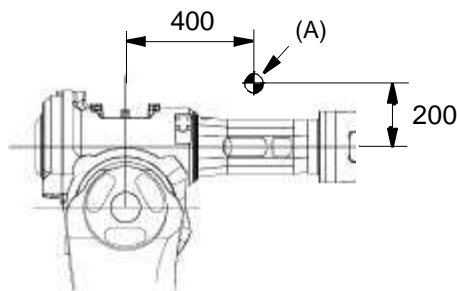

Figure 17 center of gravity for 50 kg extra load at arm housing (dimensions in mm).

Pos	Description
A	Center of gravity 50 kg.

1 Description

1.5.2 Diagrams

1.5.2 Diagrams

IRB 6600-175/2.55

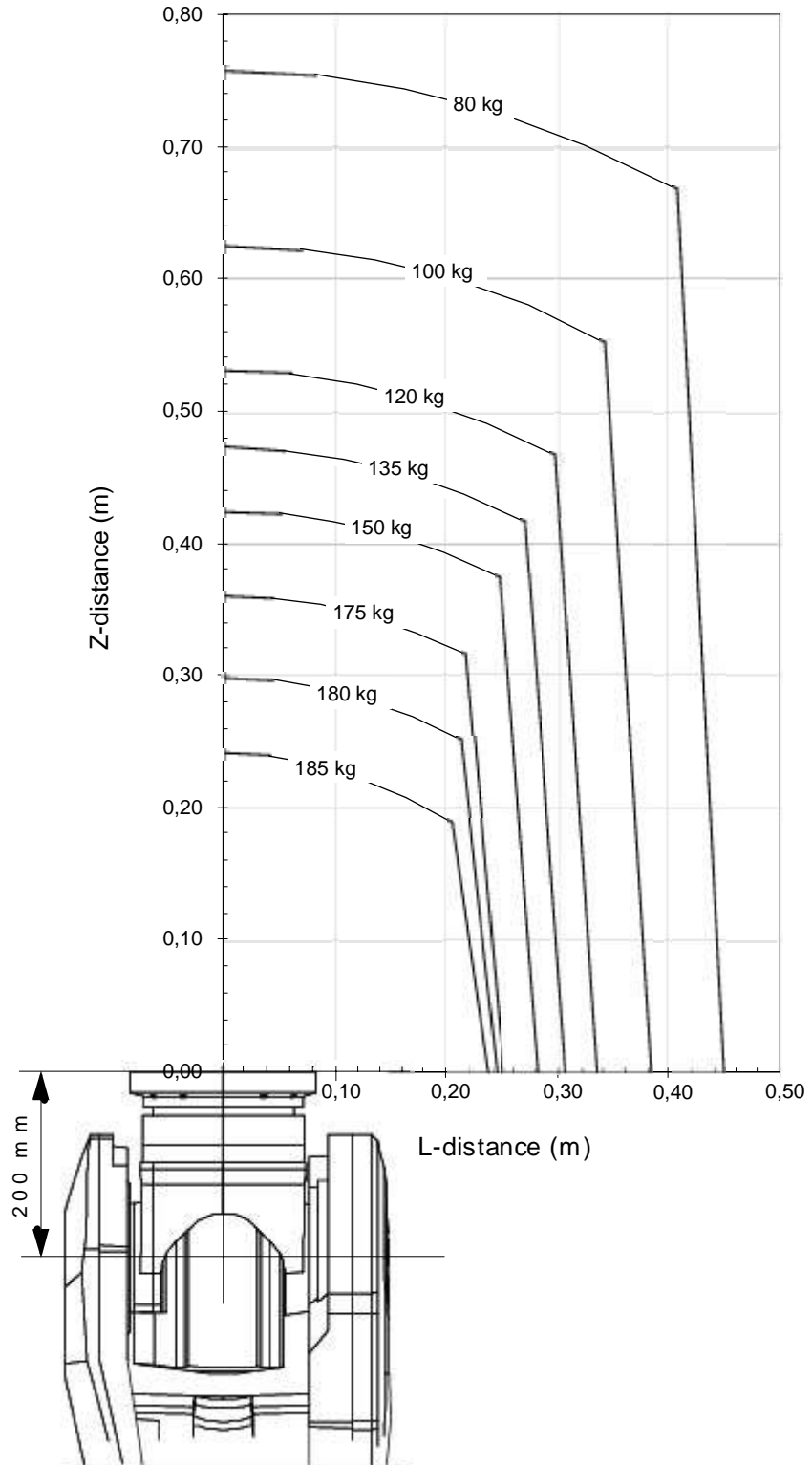

Figure 18 Maximum permitted load mounted on the robot tool flange at different positions (center of gravity).

IRB 6600-175/2.55 "Vertical Wrist" ($\pm 10^\circ$)

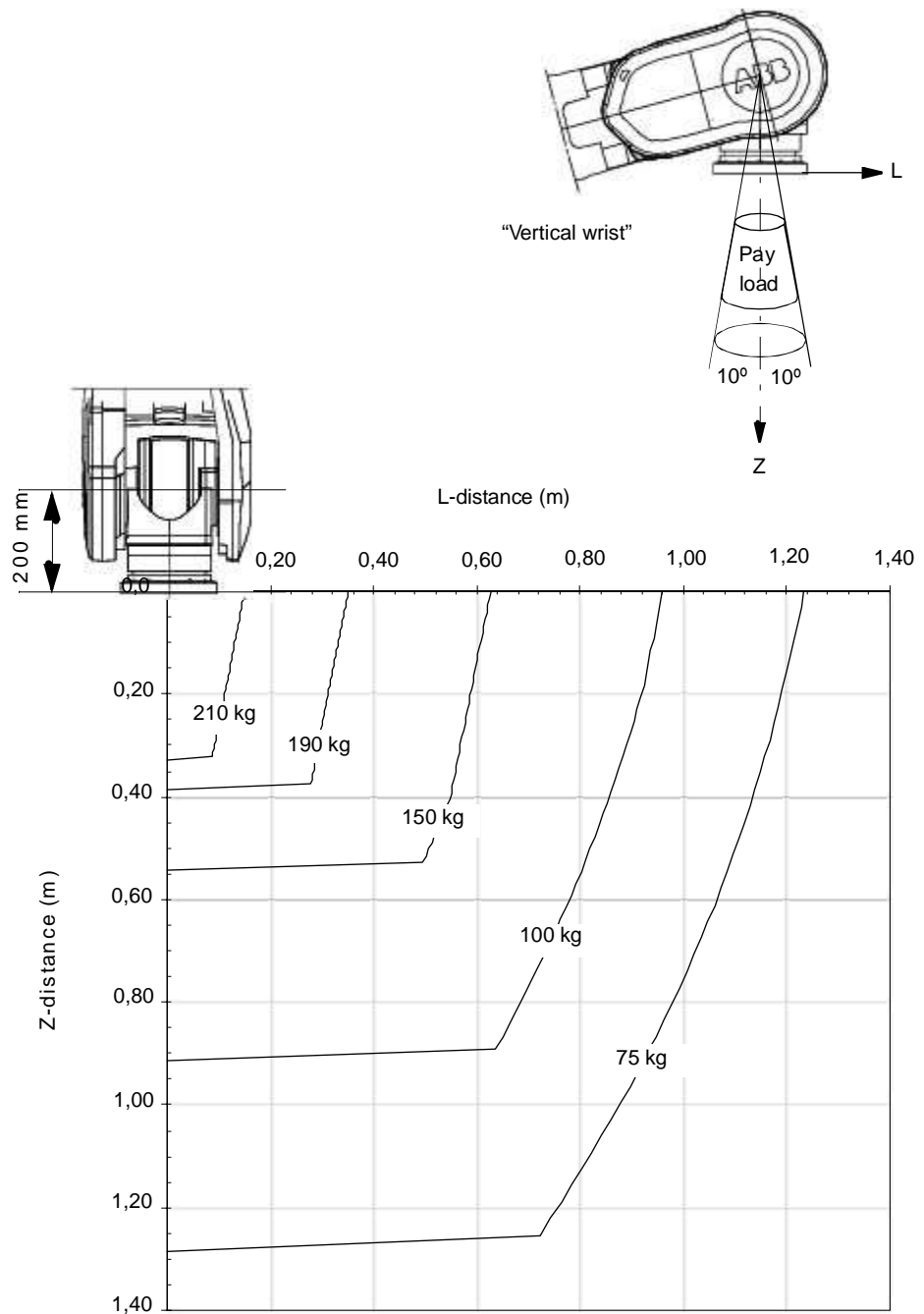

Figure 19 Maximum permitted load mounted on the robot tool flange at different positions (center of gravity) at "Vertical Wrist" ($\pm 10^\circ$), $J_0 = 15 \text{ kgm}^2$.

For wrist down (0° deviation from the vertical line).

	Description
Max load	215 kg
Z_{max}	0,310 m
L_{max}	0,133 m

1 Description

1.5.2 Diagrams

IRB 6600-225/2.55

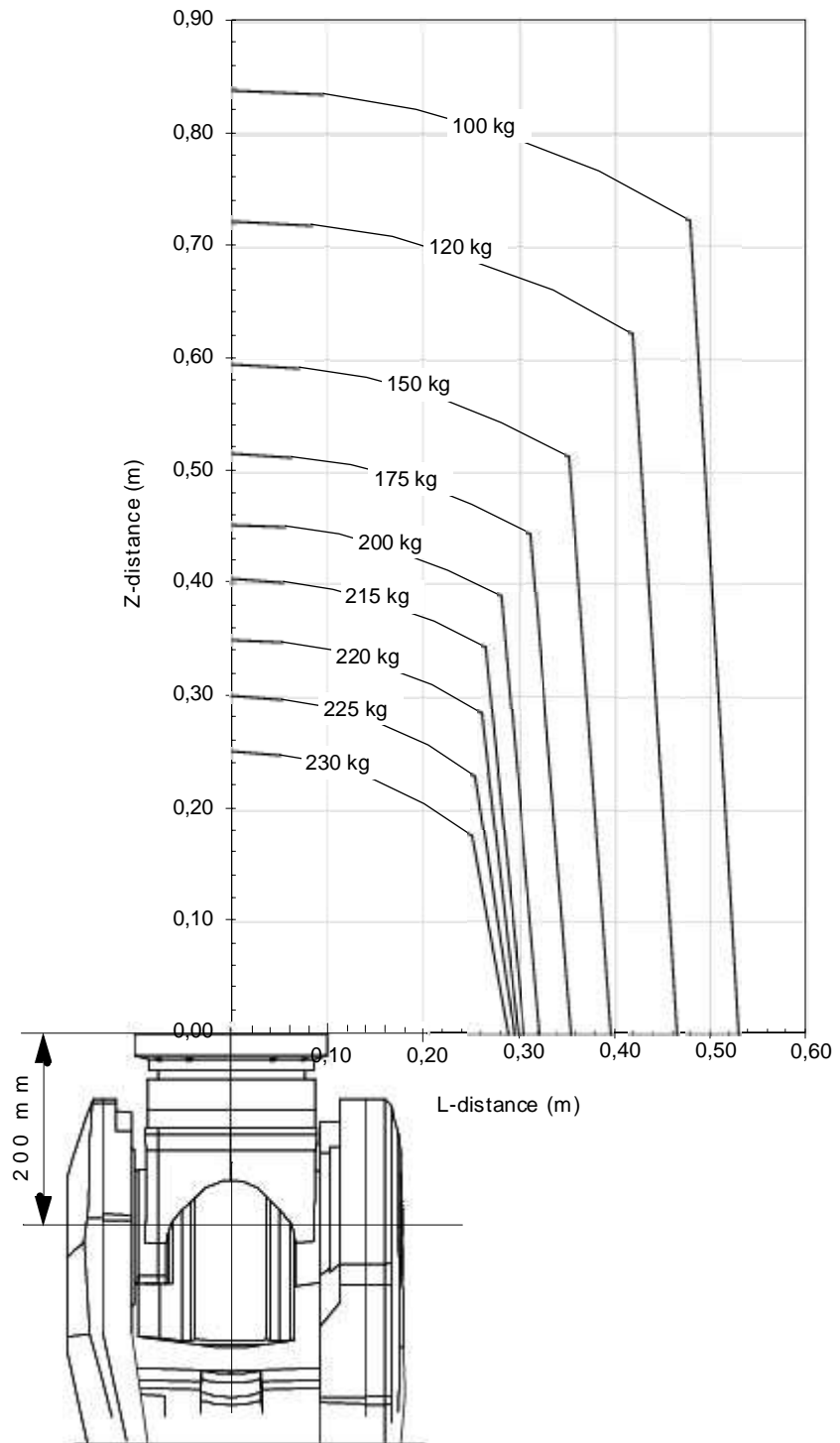

Figure 20 Maximum permitted load mounted on the robot tool flange at different positions (center of gravity).

IRB 6600-225/2.55 “Vertical Wrist” ($\pm 10^\circ$)

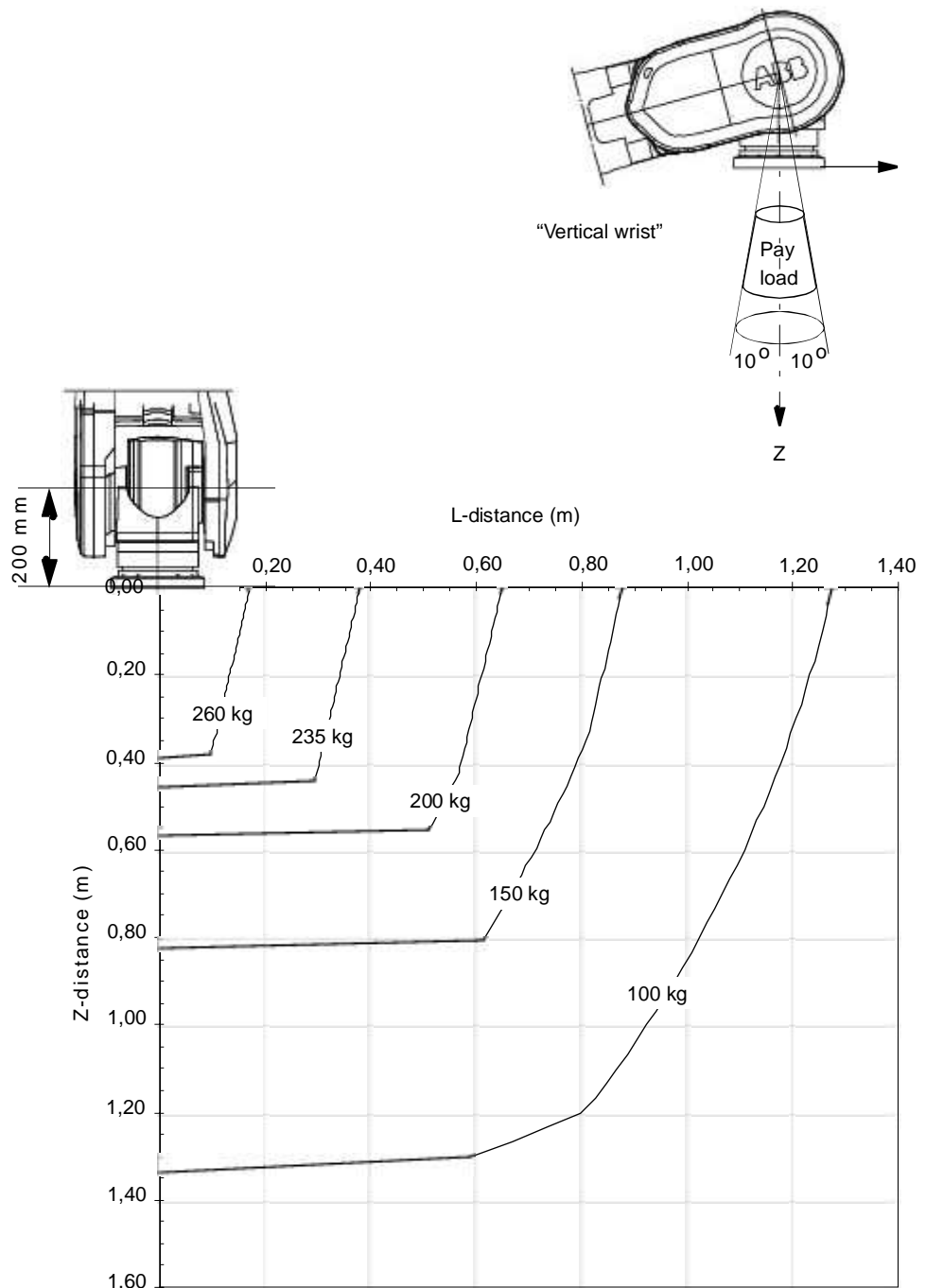

Figure 21 Maximum permitted load mounted on the robot tool flange at different positions (center of gravity) at “Vertical Wrist” ($\pm 10^\circ$).

For wrist down (0° deviation from the vertical line).

	Description
Max load	270 kg
Z _{max}	0,359 m
L _{max}	0,124 m

1 Description

1.5.2 Diagrams

IRB 6600-175/2.8

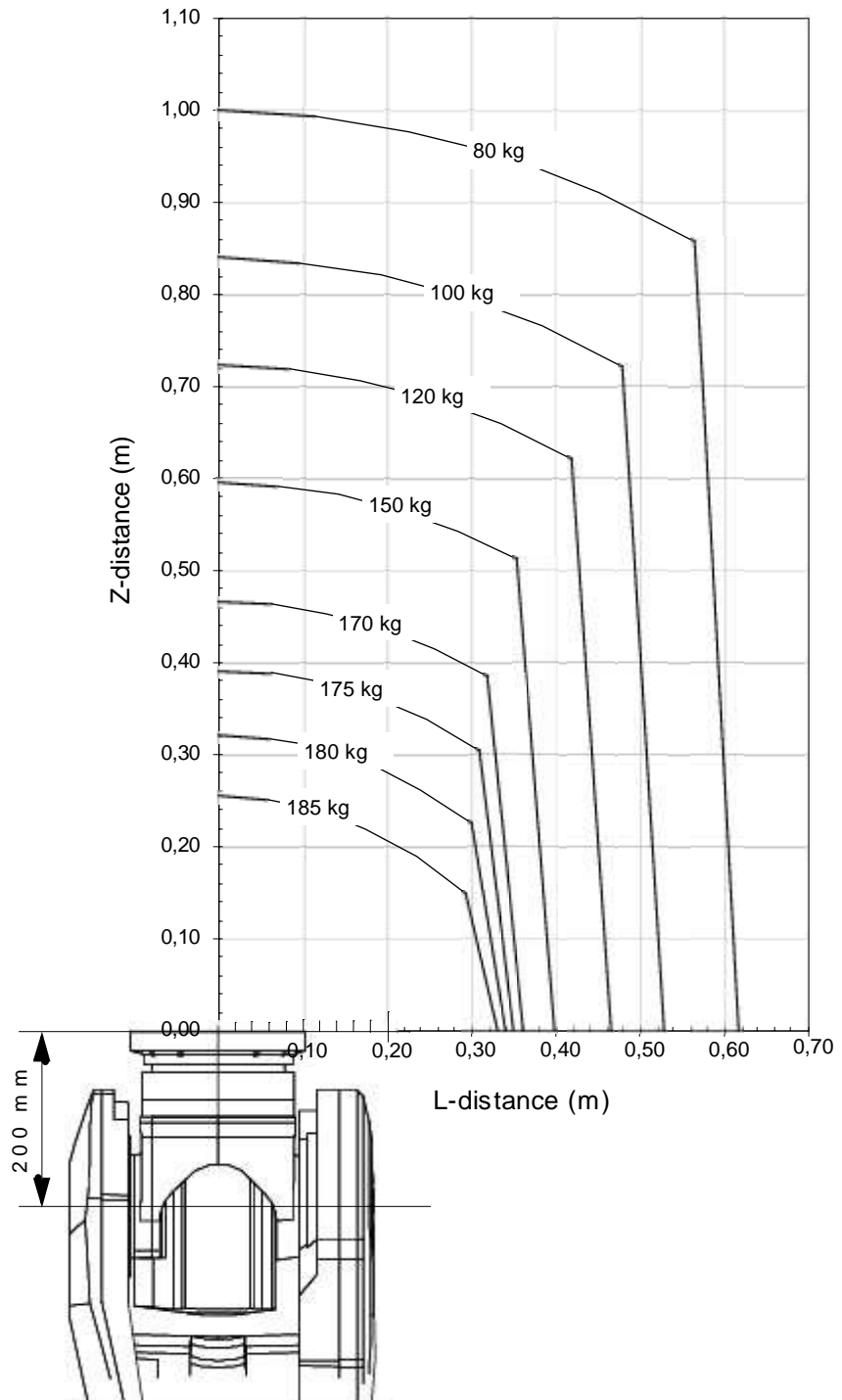

Figure 22 Maximum permitted load mounted on the robot tool flange at different positions (center of gravity).

IRB 6600-175/2.8 “Vertical Wrist” ($\pm 10^\circ$)

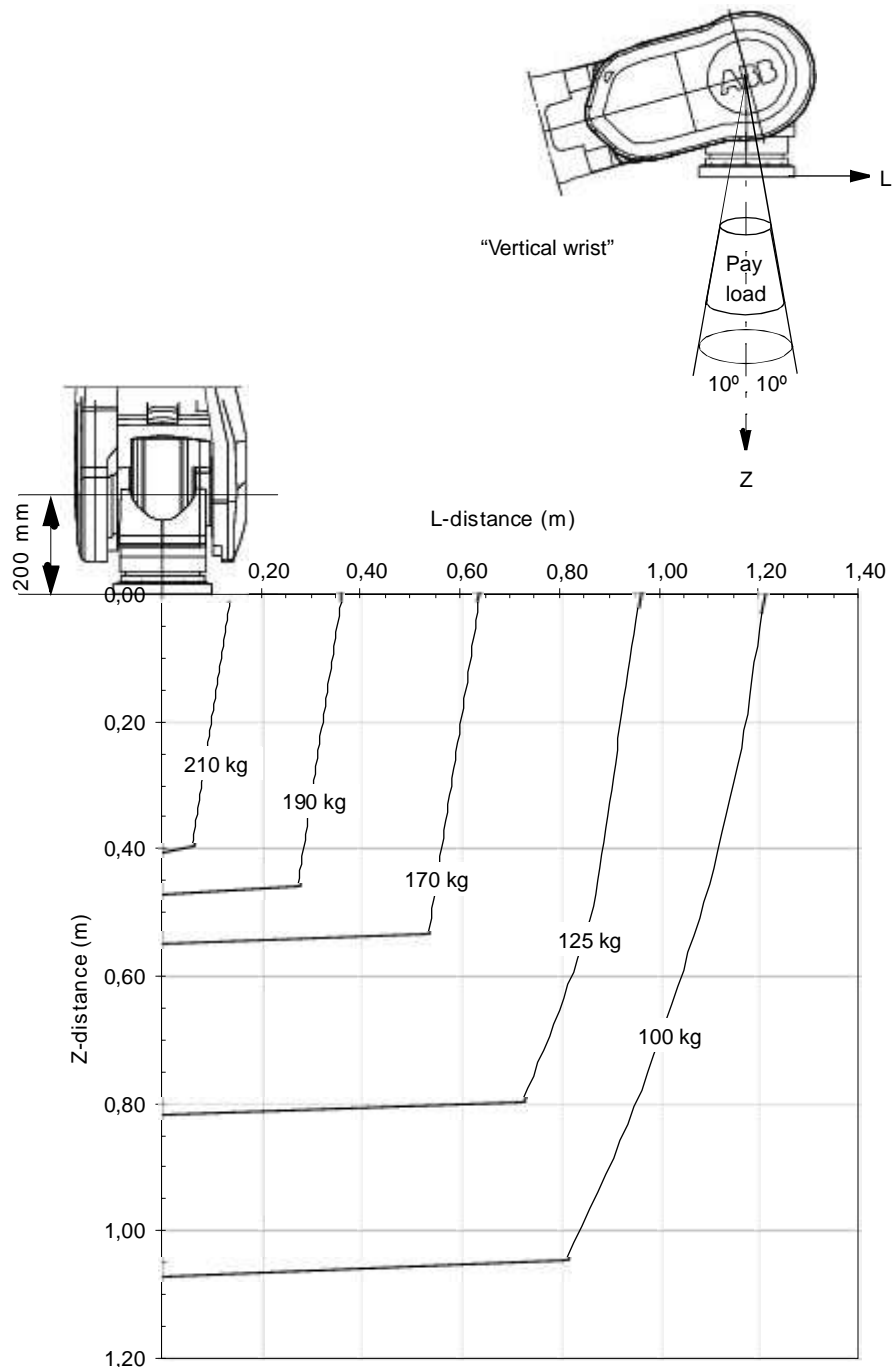

Figure 23 Maximum permitted load mounted on the robot tool flange at different positions (center of gravity) at “Vertical Wrist” ($\pm 10^\circ$).

For wrist down (0° deviation from the vertical line).

	Description
Max load	215 kg
Z _{max}	0,382 m
L _{max}	0,116 m

1 Description

1.5.2 Diagrams

IRB 6650-125/3.2 and IRB 6650S-125/3.5

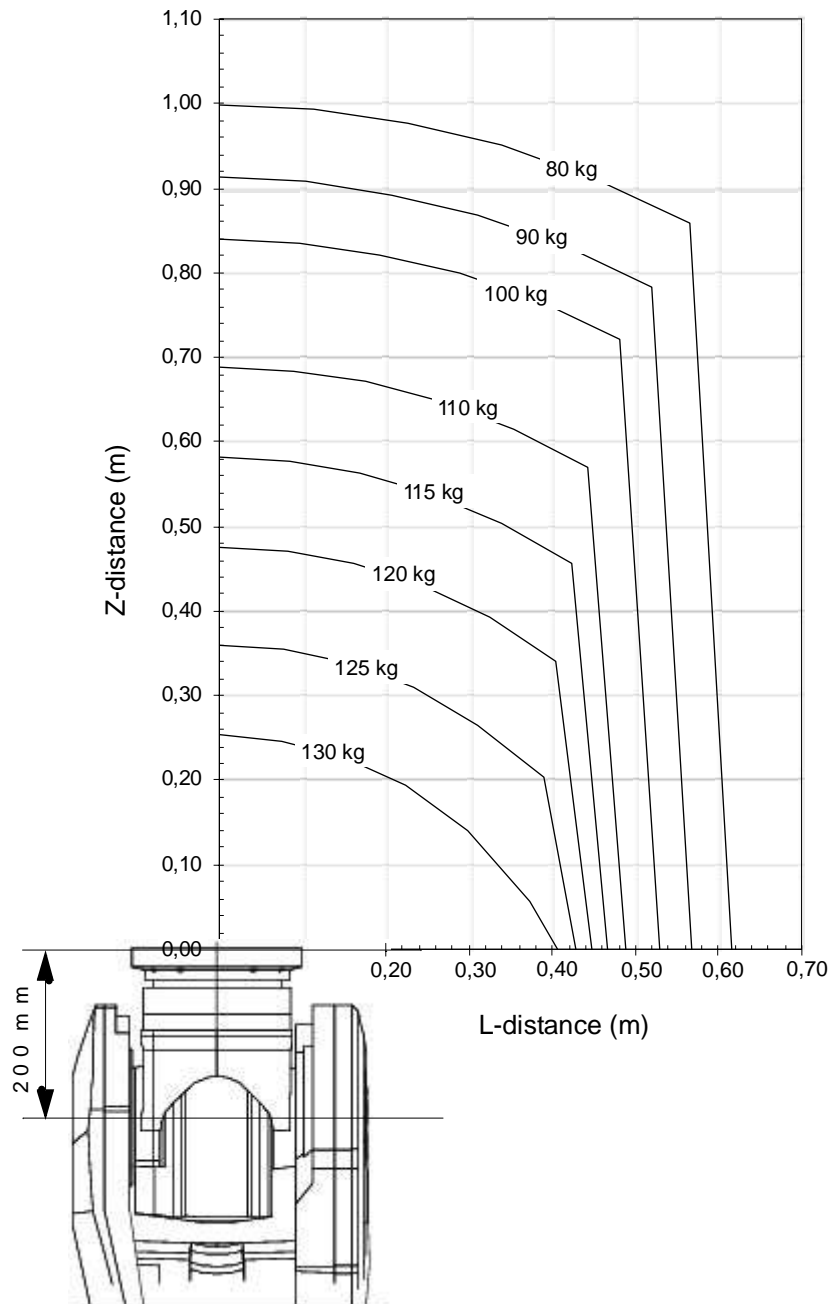

Figure 24 Maximum permitted load mounted on the robot tool flange at different positions (center of gravity).

IRB 6650-125/3.2 and IRB 6650S-125/3.5 “Vertical Wrist” ($\pm 10^\circ$)

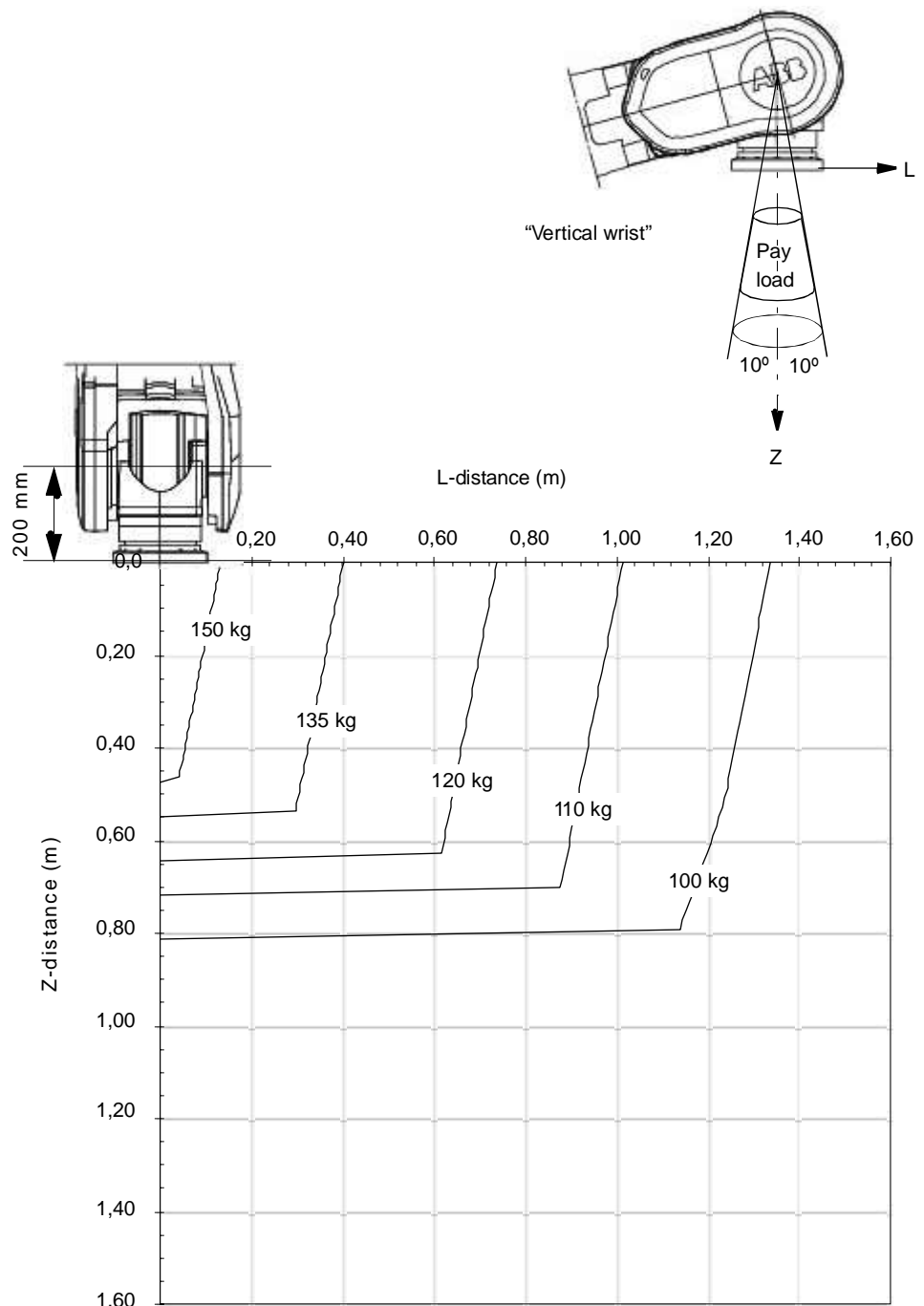

Figure 25 Maximum permitted load mounted on the robot tool flange at different positions (center of gravity) at “Vertical Wrist” ($\pm 10^\circ$).

For wrist down (0° deviation from the vertical line).

	Description
Max load	150 kg
Z _{max}	0,462 m
L _{max}	0,156 m

1 Description

1.5.2 Diagrams

IRB 6650-200/2.75 and IRB 6650S-200/3.0

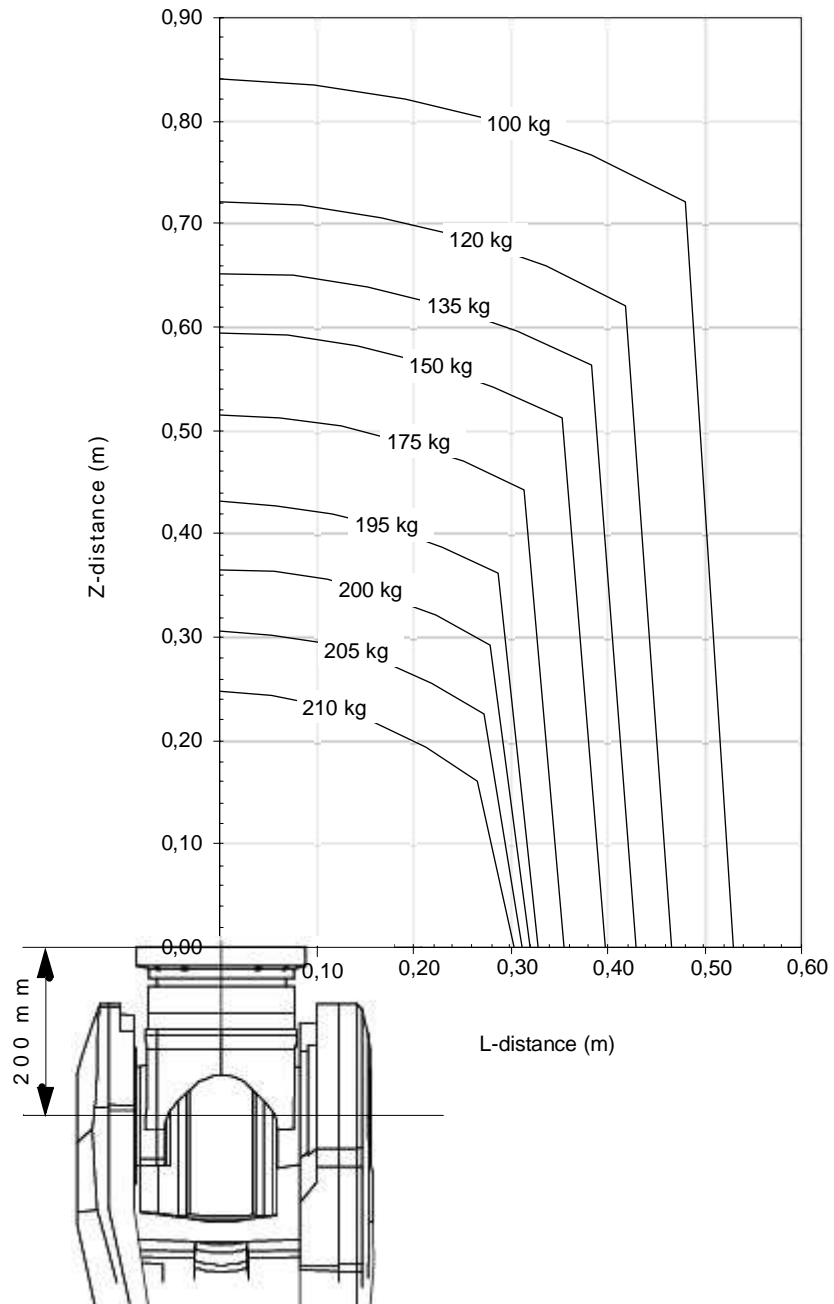

Figure 26 Maximum permitted load mounted on the robot tool flange at different positions (center of gravity).

IRB 6650-200/2.75 and IRB 6650S-200/3.0 “Vertical Wrist” ($\pm 10^\circ$)

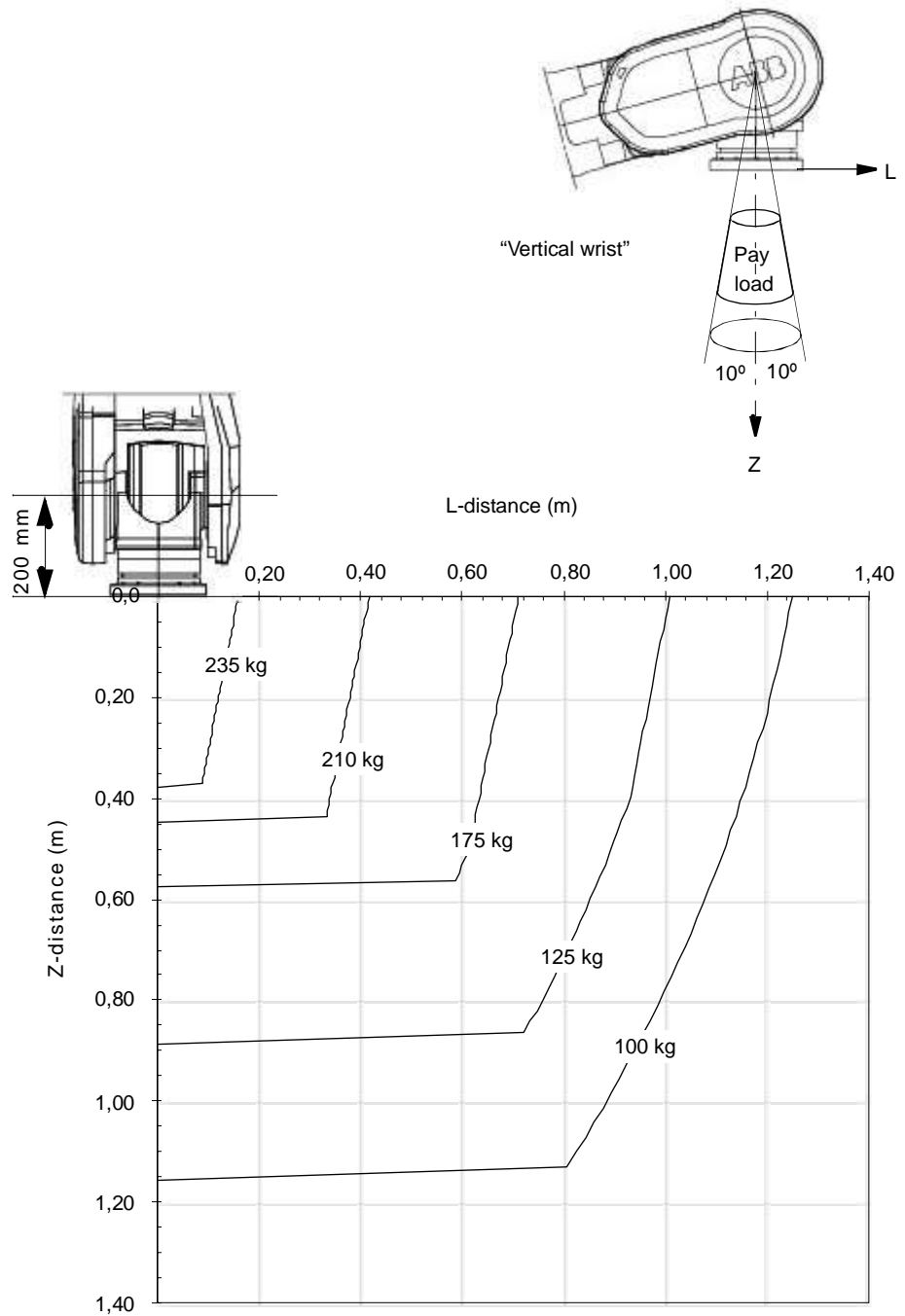

Figure 27 Maximum permitted load mounted on the robot tool flange at different positions (center of gravity) at “Vertical Wrist” ($\pm 10^\circ$).

For wrist down (0° deviation from the vertical line).

	Description
Max load	245 kg
Z _{max}	0,345 m
L _{max}	0,098 m

1 Description

1.5.2 Diagrams

IRB 6600ID-185/2.55

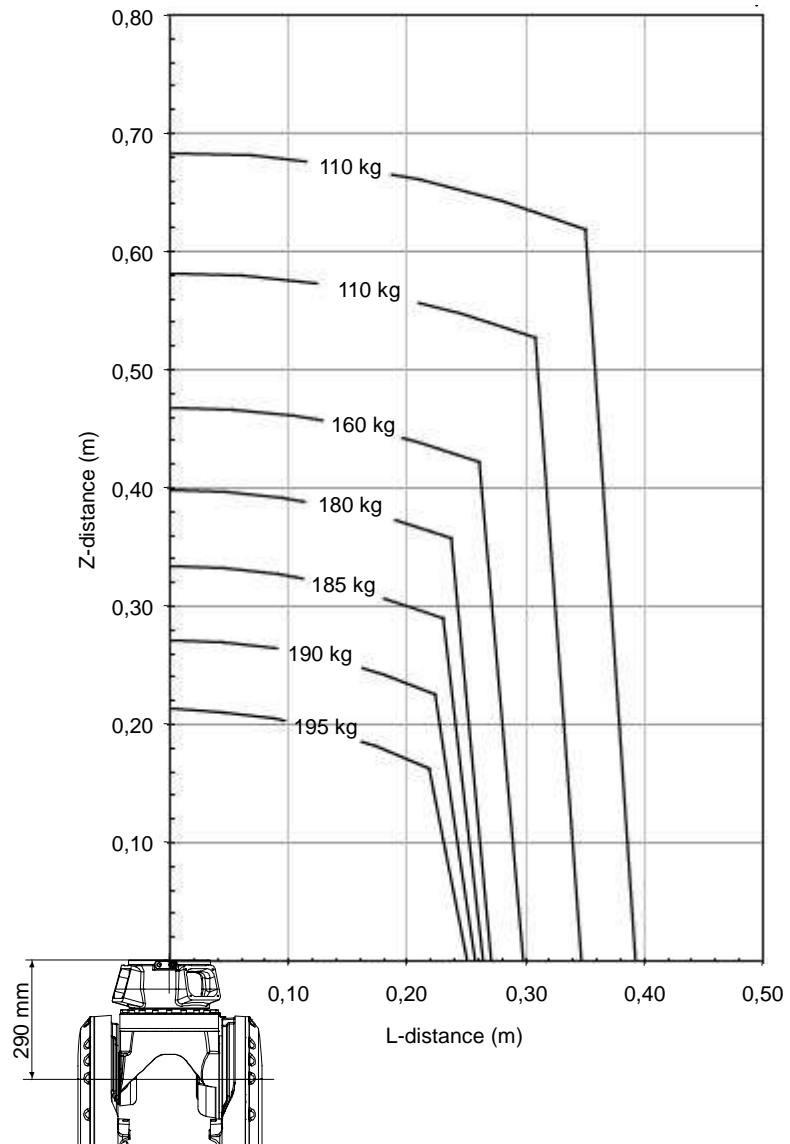

Figure 28 Maximum permitted load mounted on the robot tool flange at different positions (center of gravity).

IRB 6600ID-185/2.55 “Vertical Wrist” ($\pm 10^\circ$)

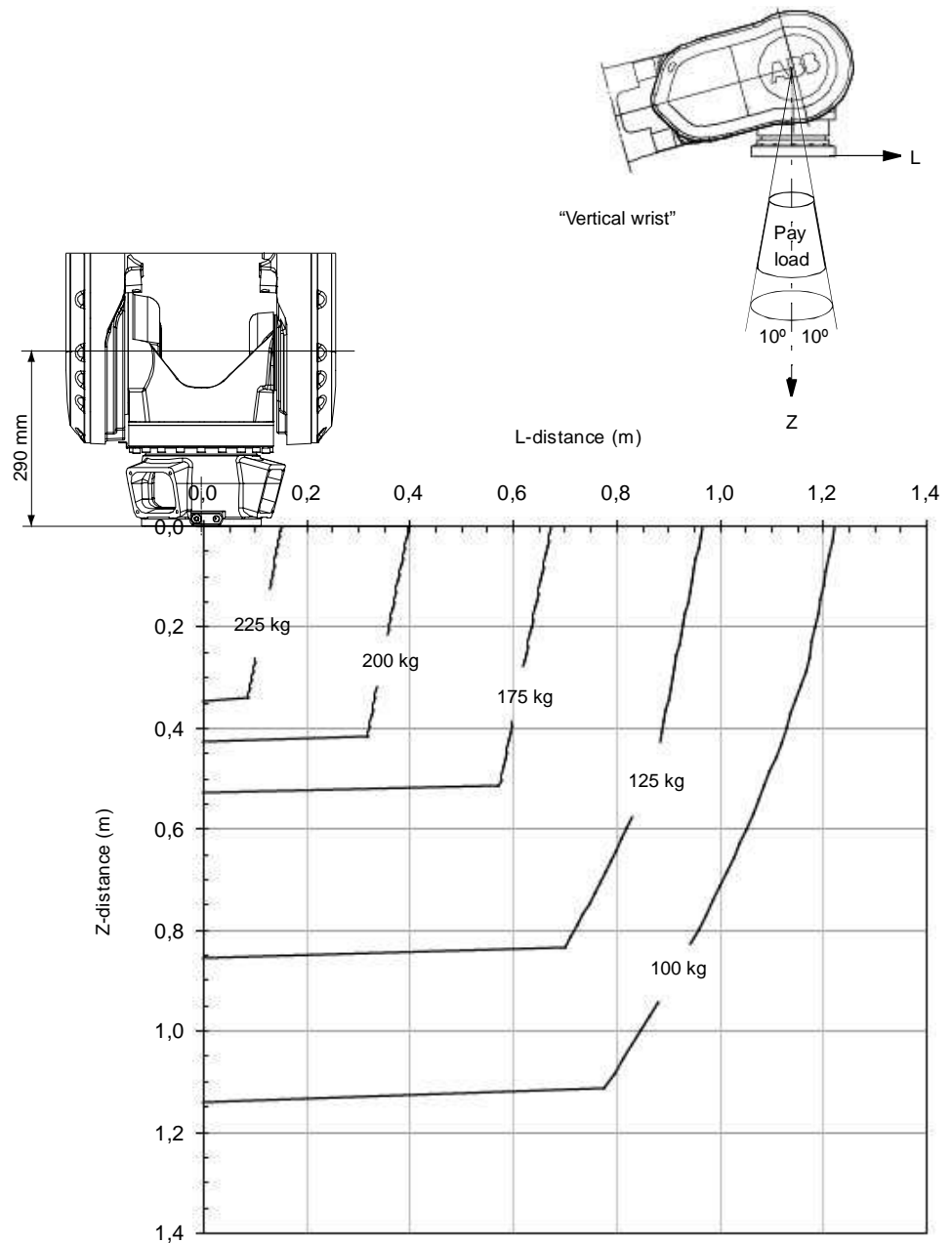

Figure 29 Maximum permitted load mounted on the robot tool flange at different positions (center of gravity) at “Vertical Wrist” ($\pm 10^\circ$).

For wrist down (0° deviation from the vertical line).

	Description
Max load	225 kg
Z _{max}	0,345 m
L _{max}	0,153 m

1 Description

1.5.2 Diagrams

IRB 6650ID-170/2.75

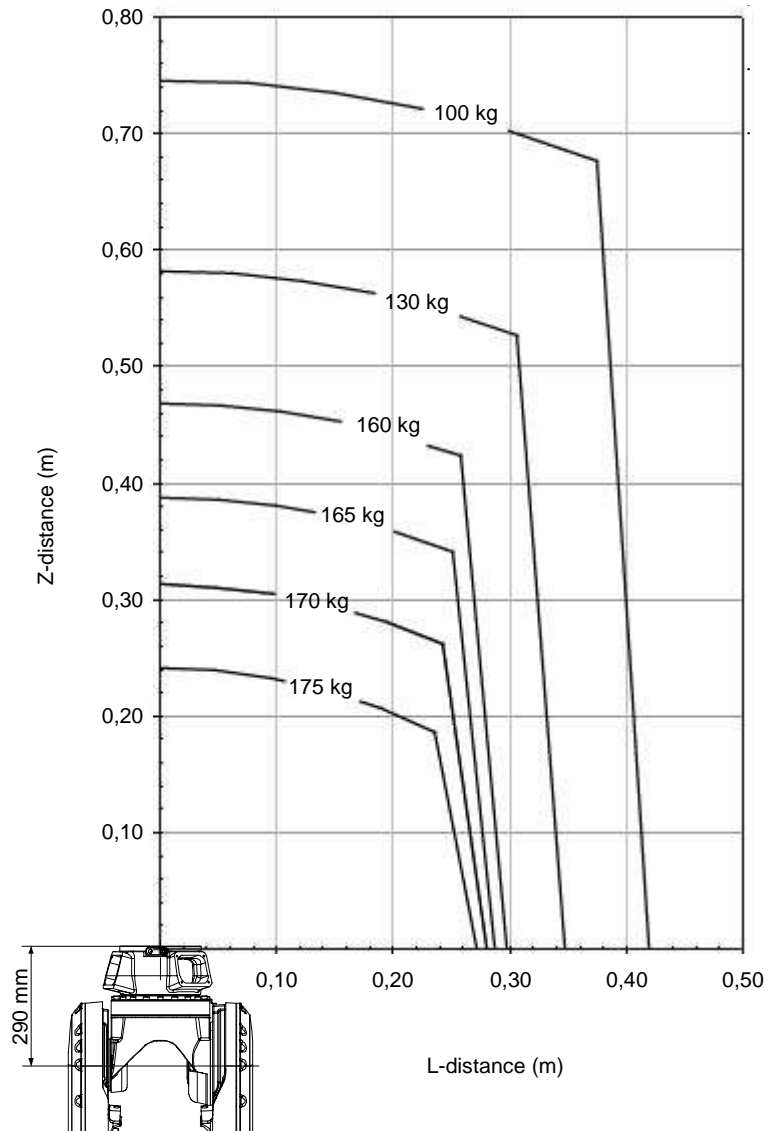

Figure 30 Maximum permitted load mounted on the robot tool flange at different positions (center of gravity).

IRB 6650ID 170/2.75 “Vertical Wrist” ($\pm 10^\circ$)

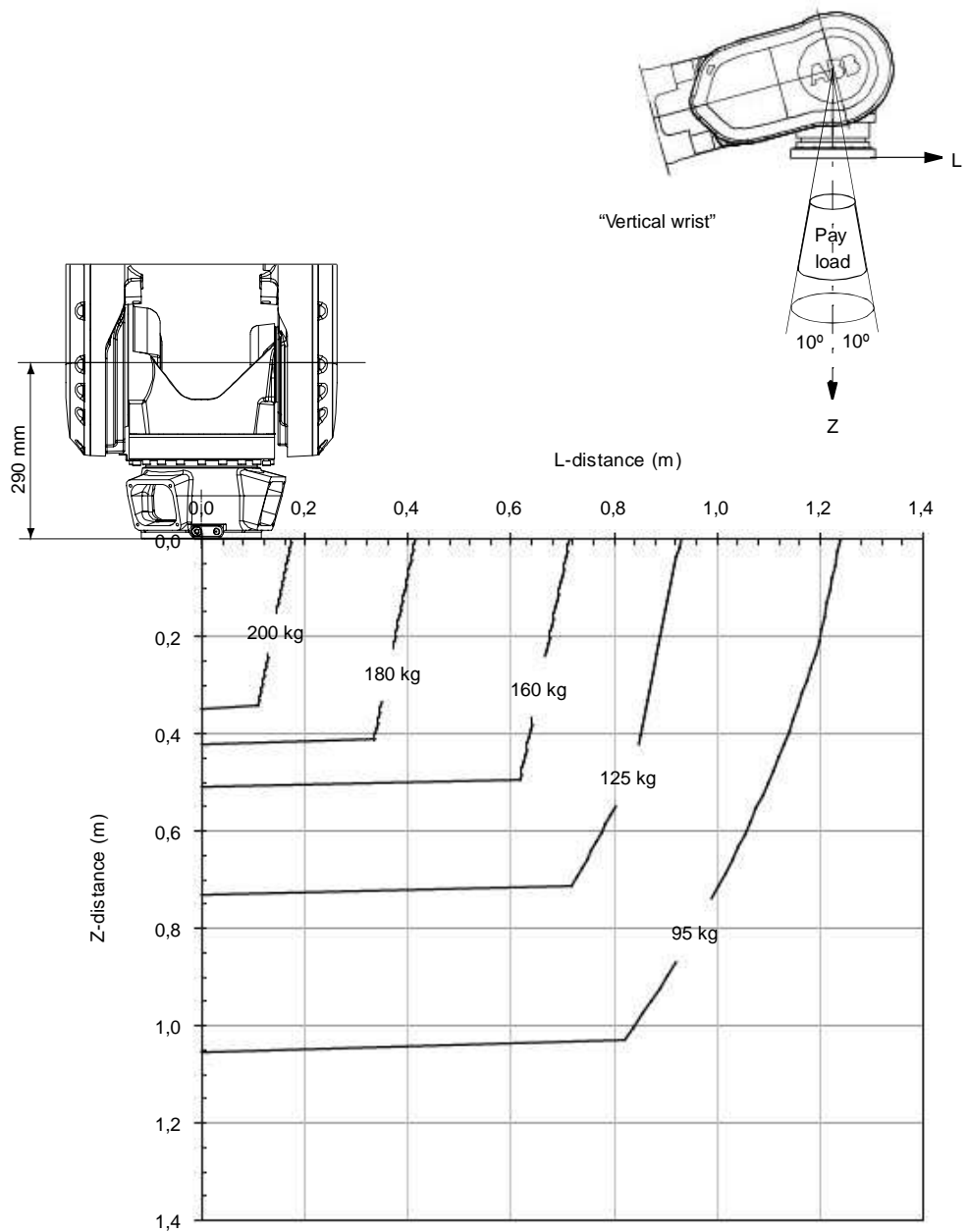

Figure 31 Maximum permitted load mounted on the robot tool flange at different positions (center of gravity) at “Vertical Wrist” ($\pm 10^\circ$).

For wrist down (0° deviation from the vertical line).

	Description
Max load	200 kg
Z _{max}	0,349 m
L _{max}	0,177 m

1 Description

1.5.3 Maximum load and moment of inertia for full and limited axis 5 (center line down) movement

1.5.3 Maximum load and moment of inertia for full and limited axis 5 (center line down) movement



Load in kg, Z and L in m and J in kgm^2

Full movement of axis 5 ($\pm 120^\circ/\pm 100^\circ$ for ID)

Axis	Robot Type	Maximum moment of inertia
5	225/2.55, 175/2.8, 125/3.2, 125/3.5, 200/2.75 and 200/3.0	$Ja5 = \text{Load} \cdot ((Z + 0,200)^2 + L^2) + J_{0L} \leq 250 \text{ kgm}^2$
	ID-170/2.75 and ID-185/2.55	$Ja5 = \text{Load} \cdot ((Z + 0,290)^2 + L^2) + J_{0L} \leq 250 \text{ kgm}^2$
	175/2.55	$Ja5 = \text{Load} \cdot ((Z + 0,200)^2 + L^2) + J_{0L} \leq 195 \text{ kgm}^2$
6	225/2.55, 175/2.8, 125/3.2, 125/3.5, 200/2.75, 200/3.0, ID-170/2.75 and ID-185/2.55	$Ja6 = \text{Load} \cdot L^2 + J_{0Z} \leq 185 \text{ kgm}^2$
	175/2.55	$Ja6 = \text{Load} \cdot L^2 + J_{0Z} \leq 145 \text{ kgm}^2$

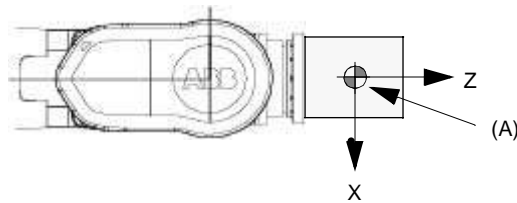

Figure 32 Moment of inertia when full movement of axis 5.

Pos	Description
A	Center of gravity.

	Description
J_{0L}	Maximum own moment of inertia around the maximum vector in the X-Y-plane.
J_{0Z}	Maximum own moment of inertia around Z.

Limited axis 5, center line down

Axis	Robot Type	Maximum moment of inertia
5	225/2.55, 175/2.8, 125/3.2, 125/3.5, 200/2.75 and 200/3.0	$Ja5 = \text{Load} \cdot ((Z + 0,200)^2 + L^2) + J_{0L} \leq 275 \text{ kgm}^2$
	ID-170/2.75 and ID-185/2.55	$Ja5 = \text{Load} \cdot ((Z + 0,290)^2 + L^2) + J_{0L} \leq 275 \text{ kgm}^2$
	175/2.55	$Ja5 = \text{Load} \cdot ((Z + 0,200)^2 + L^2) + J_{0L} \leq 215 \text{ kgm}^2$
6	225/2.55, 175/2.8, 125/3.2, 125/3.5, 200/2.75, 200/3.0, ID-170/2.75 and ID-185/2.55	$Ja6 = \text{Load} \cdot L^2 + J_{0Z} \leq 250 \text{ kgm}^2$
	175/2.55	$Ja6 = \text{Load} \cdot L^2 + J_{0Z} \leq 195 \text{ kgm}^2$

1.5.3 Maximum load and moment of inertia for full and limited axis 5 (center line down) movement

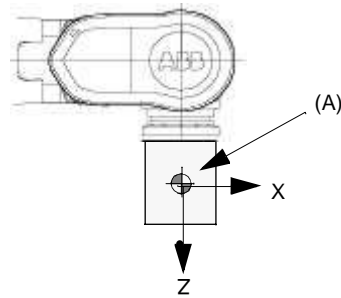

Figure 33 Moment of inertia when axis 5 center line down.

Pos	Description
A	Center of gravity.
	Description
J_{0L}	Maximum own moment of inertia around the maximum vector in the X-Y-plane.
J_{0Z}	Maximum own moment of inertia around Z.

1 Description

1.5.4 Mounting equipment

1.5.4 Mounting equipment

General

Extra loads can be mounted on the upper arm housing, the lower arm, and on the frame. Definitions of distances and masses are shown in Figure 34 and Figure 35. The robot is supplied with holes for mounting extra equipment (see Figure 36). Maximum allowed arm load depends on center of gravity of arm load and robot payload.



No extra loads for IRB 6600ID/6650ID.

Upper arm

Allowed extra load on upper arm housing plus the maximum handling weight (See Figure 34):

$M1 \leq 50$ kg with distance $a \leq 500$ mm, center of gravity in axis 3 extension.

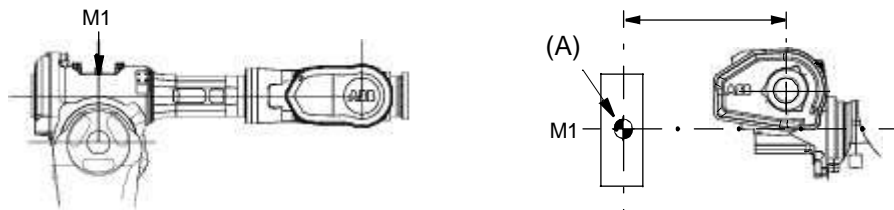

Figure 34 Permitted extra load on upper arm.

Pos	Description
A	Mass center

Frame (Hip Load)

	Description
Permitted extra load on frame	$J_H = 200 \text{ kgm}^2$
Recommended position (see Figure 35)	$J_H = J_{H0} + M4 \cdot R^2$ where: J_{H0} is the moment of inertia of the equipment. R is the radius (m) from the center of axis 1. $M4$ is the total mass (kg) of the equipment including bracket and harness (≤ 500 kg).

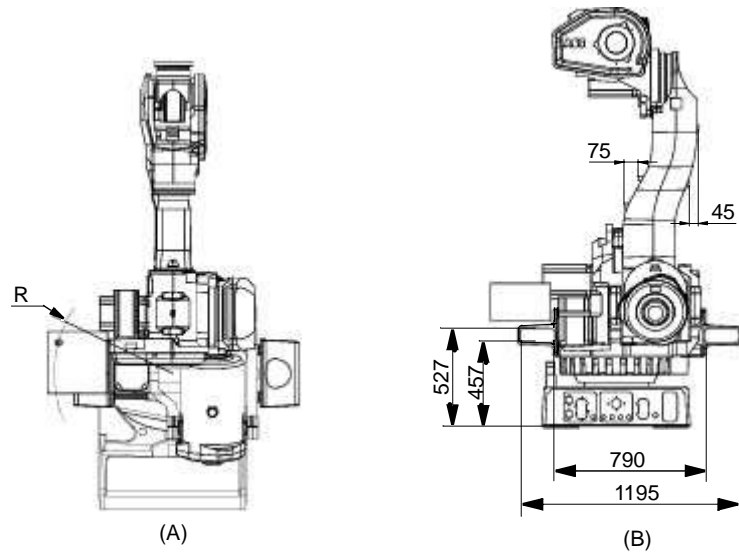

Figure 35 Extra load on the frame of IRB 6600 (dimensions in mm).

Pos	Description
A	View from above.
B	View from the rear.

1 Description

1.5.5 Mounting of hip load

1.5.5 Mounting of hip load

General

The extra load can be mounted on the frame. Holes for mounting see Figure 36 and Figure 37. When mounting on the frame all four holes (2x2, Ø16) on one side must be used.

Holes for mounting extra equipment on IRB 6600/6650 and IRB 6600ID/6650ID

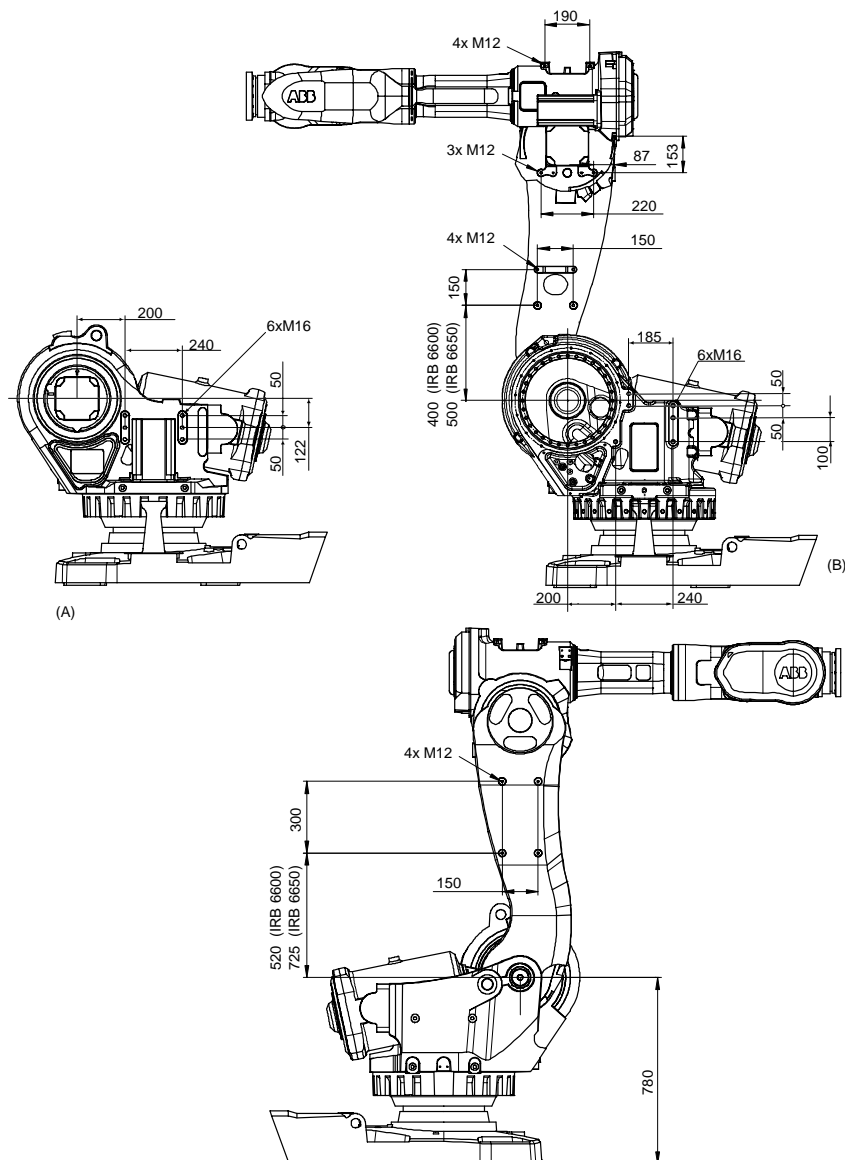

Figure 36 Holes for mounting extra equipment on the upper and the lower arm, and the frame on IRB 6600/ 6650 (dimensions in mm).

Pos	Description
A	Differences for Type A
B	Type B

Illustration

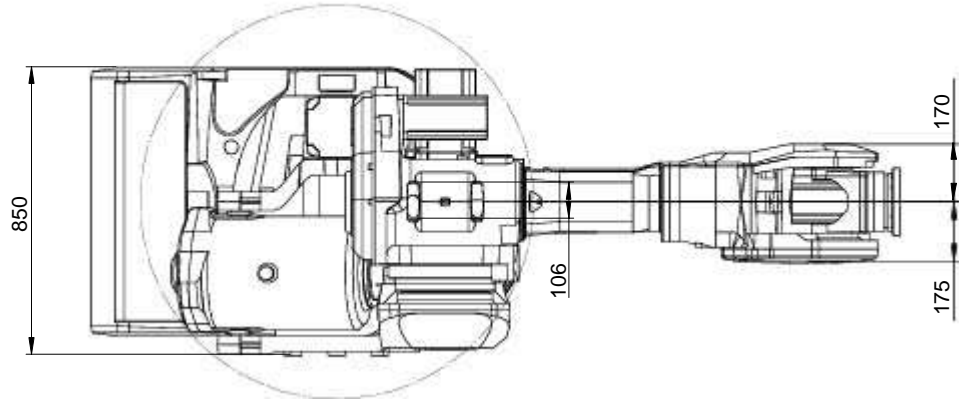

Figure 37 Holes for mounting of extra load on the upper arm on IRB 6600/6650 (dimensions in mm).

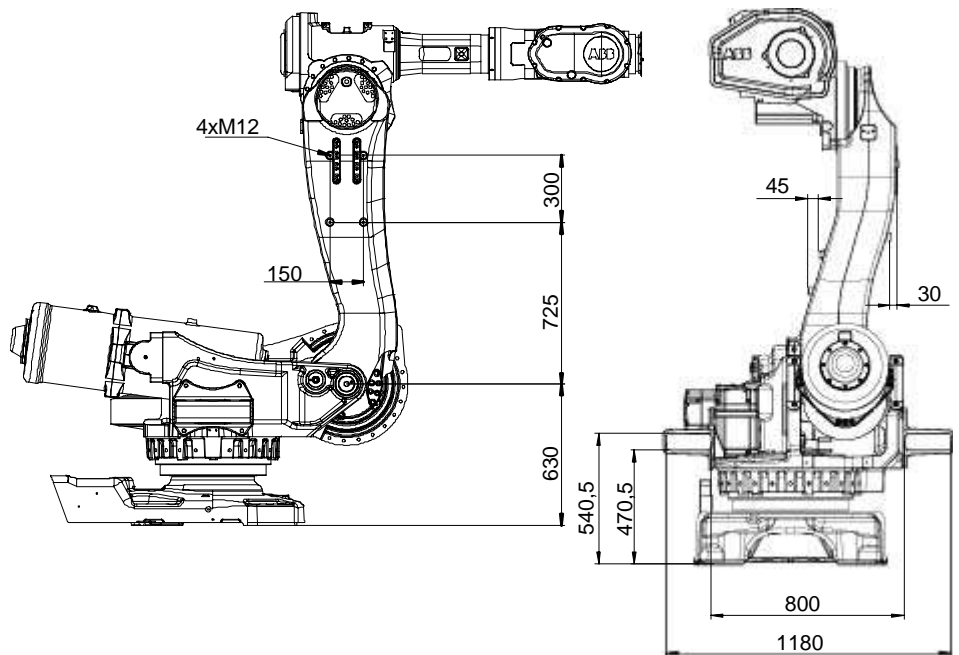

Figure 38 Holes for mounting extra load on upper arm on IRB 6650S (dimensions in mm).

1 Description

1.5.5 Mounting of hip load

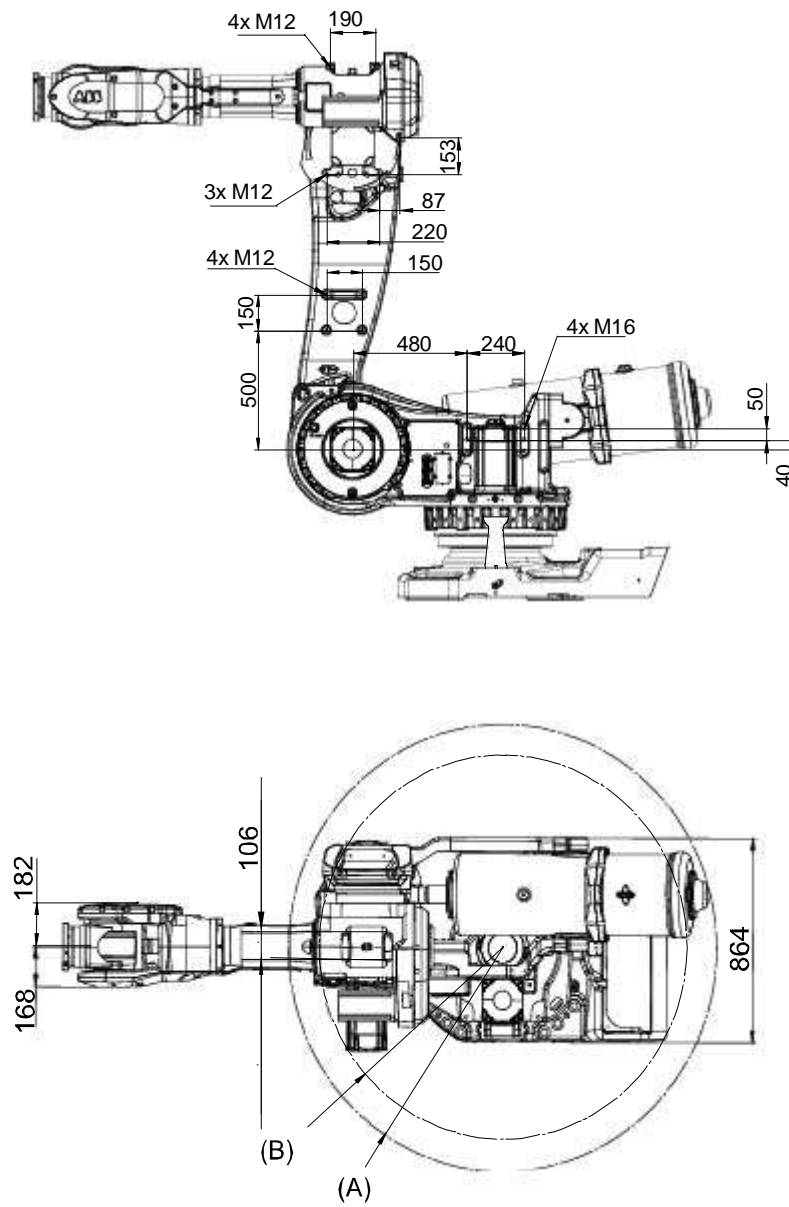

Figure 39 Holes for mounting extra load on upper arm on IRB 6650S (dimensions in mm).

Illustration

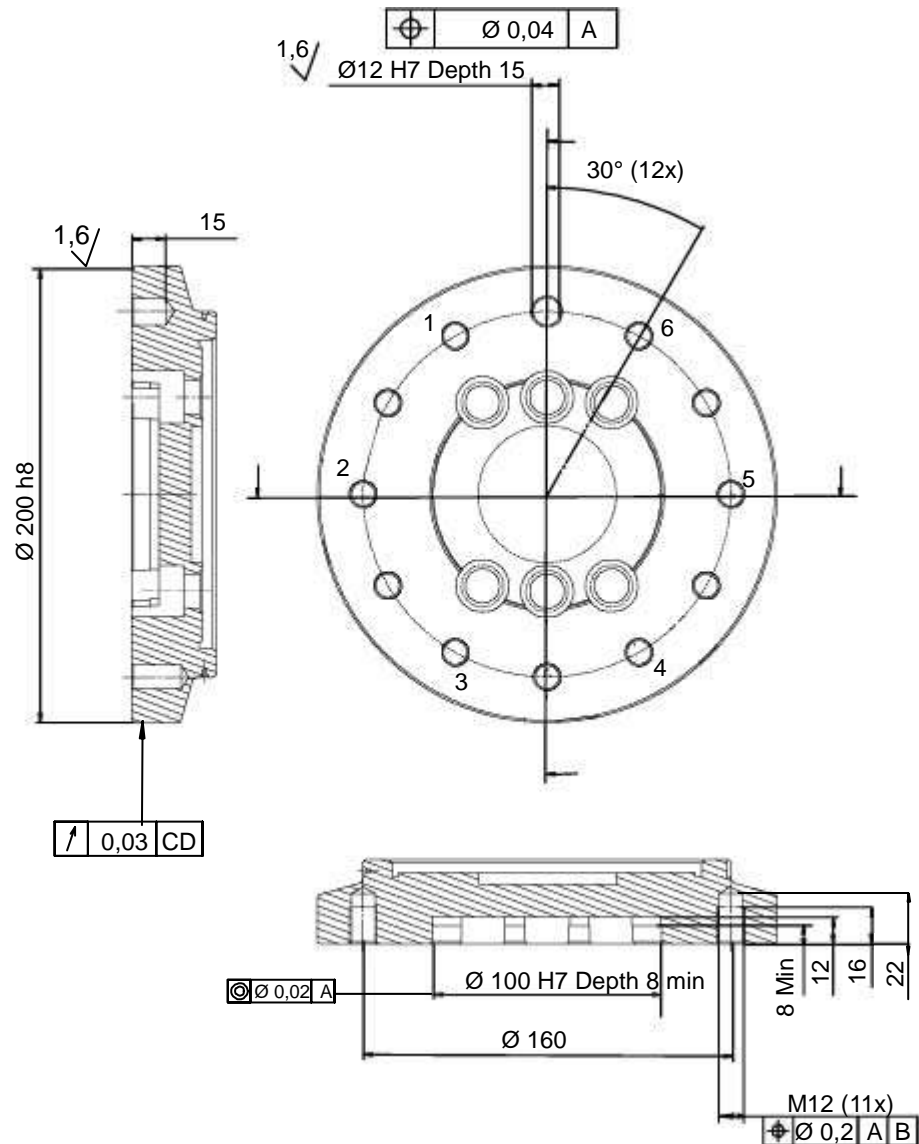

Figure 40 Robot tool flangeSS-EN ISO 9409-1:2004 (dimensions in mm).

Robot Type	Handling capacity (kg)	Reach (m)
IRB 6600	175	2.55

For fastening of gripper-tool-flange to robot-tool-flange every other one (see fig.) of the bolt holes for 6 bolts quality class 12.9 shall be used.

1 Description

1.5.5 Mounting of hip load

Illustration

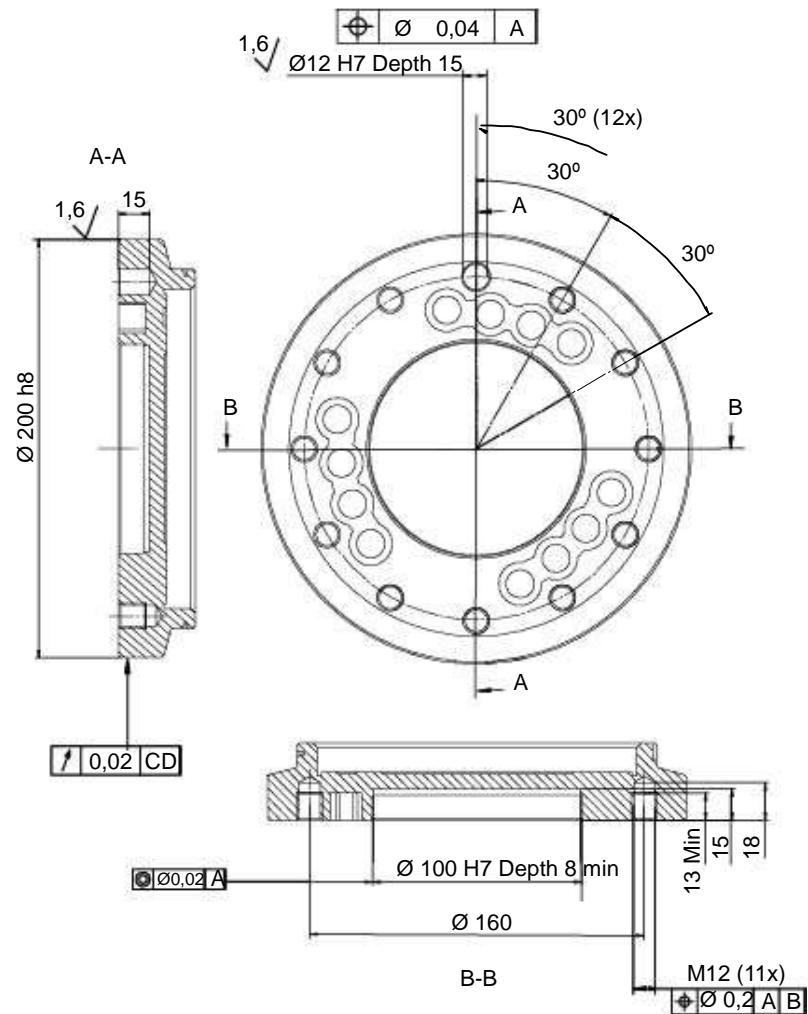

Figure 41 Robot tool flange ISO/DIS 9409-1:2002 (dimensions in mm).

Robot Type	Handling capacity (kg)	Reach (m)
IRB 6600	225	2.55
IRB 6600	175	2.8
IRB 6650	125	3.2
IRB 6650	200	2.75
IRB 6650S	125	3.5
IRB 6650S	200	3.0

For fastening of gripper-tool-flange to robot-tool-flange all bolt holes for 11 bolts quality class 12.9 shall be used.

Illustration

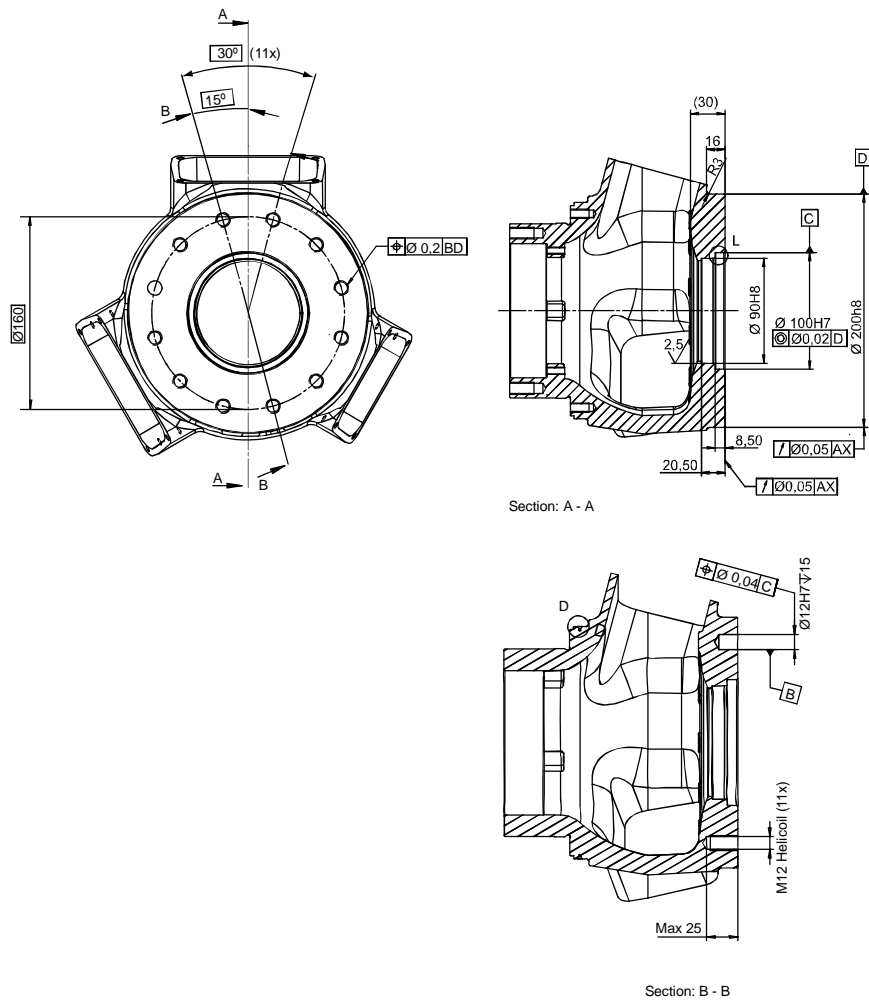

Figure 42 Robot tool flange SS-EN ISO 9409-1:2004 (dimensions in mm).

Robot Type	Handling capacity (kg)	Reach (m)
IRB 6600ID	185	2.55
IRB 6650ID	170	2.75

For fastening of gripper-tool-flange to robot-tool-flange all bolt holes for 11 bolts quality class 12.9 shall be used.

1 Description

1.6.1 Introduction

1.6 Maintenance and Troubleshooting

1.6.1 Introduction

General

The robot requires only minimum maintenance during operation. It has been designed to make it as easy to service as possible:

- Maintenance-free AC motors are used.
 - Oil is used for the gear boxes.
 - The cabling is routed for longevity, and in the unlikely event of a failure, its modular design makes it easy to change.
-

Maintenance

The following maintenance is required:

- Changing filter for the transformer/drive unit cooling every year.
- Changing batteries every third year.

The maintenance intervals depend on the use of the robot. For detailed information on maintenance procedures, see Maintenance section in the Product Manual.

1.7 Robot Motion

1.7.1 Introduction

Type of Motion

Axis	Type of motion	Range of movement		
		IRB 6600/6650	IRB 6650S	IRB 6600ID/6650ID
1	Rotation Motion	+ 180° to - 180° + 220° to - 220° (option)	+ 180° to - 180° + 220° to - 220° (option)	+ 180° to - 180°
2	Arm motion	+ 85° to - 65°	+ 160° to - 40°	+ 85° to - 65°
3	Arm motion	+ 70° to - 180°	+ 70° to - 180°	+ 70° to - 180°
4	Wrist motion	+ 300° to - 300°	+ 300° to - 300°	+ 300° to - 300° ¹
5	Bend motion	+ 120° to - 120°	+ 120° to - 120°	+ 100° to - 100°
6	Turn motion	+ 360° to - 360° default ± 96 Rev ²	+ 360° to - 360° default ± 96 Rev ²	+ 300° to - 300° ± 300° Max. ³

1. For IRB 6600ID/6650ID axis 4 and 6 together max. +300° to -300°.

2. Rev. = Revolutions

3. The minimum combination of axis 4 and axis 6.

1 Description

1.7.1 Introduction

Illustration

Robot Type	Handling capacity (kg)	Reach (m)
IRB 6600	175	2.55
	225	2.55
IRB 6600ID	185	2.55

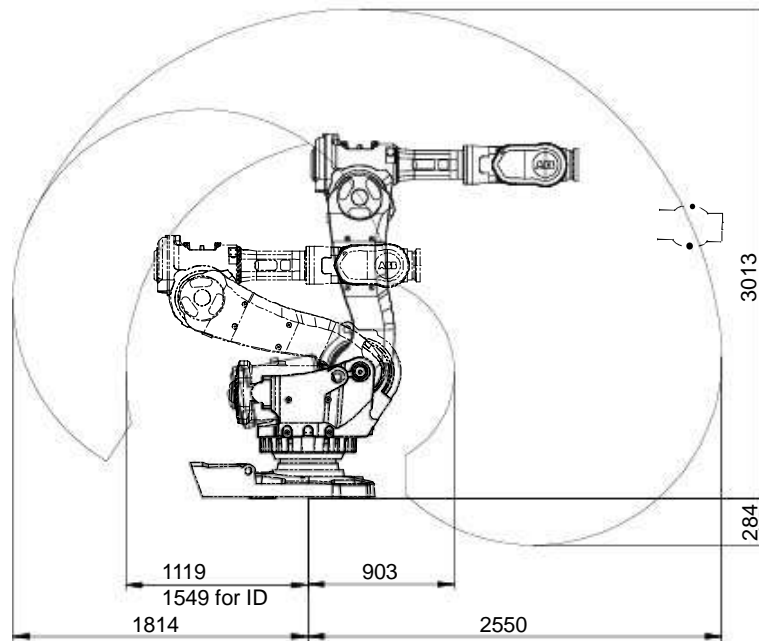

Figure 43 The extreme positions of the robot arm specified at the wrist center (dimensions in mm).

Illustration

Robot Type	Handling capacity (kg)	Reach (m)
IRB 6600	175	2.8

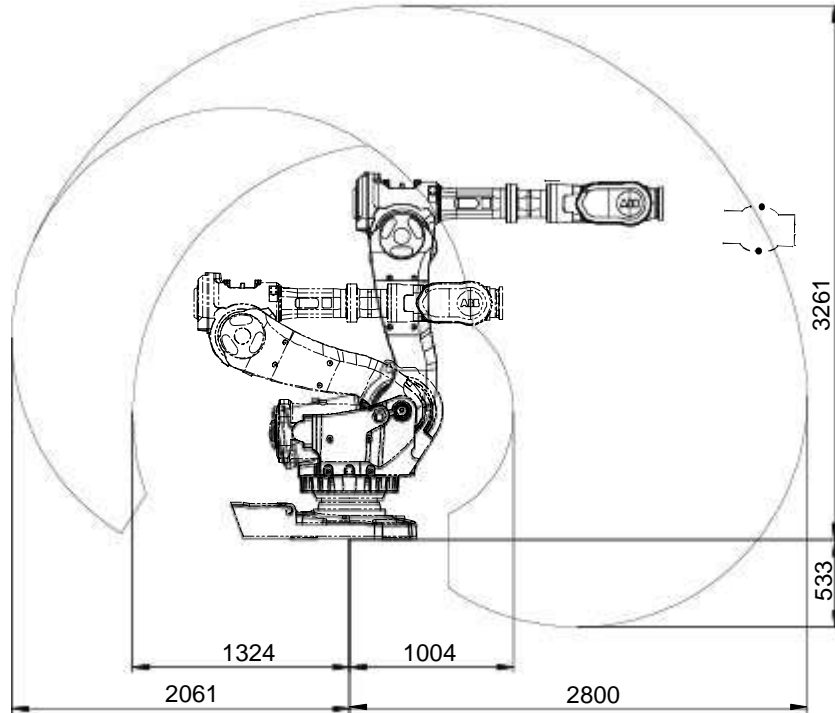

Figure 44 The extreme positions of the robot arm specified at the wrist center (dimensions in mm).

1 Description

1.7.1 Introduction

Illustration

Robot Type	Handling capacity (kg)	Reach (m)
IRB 6650	125	3.2

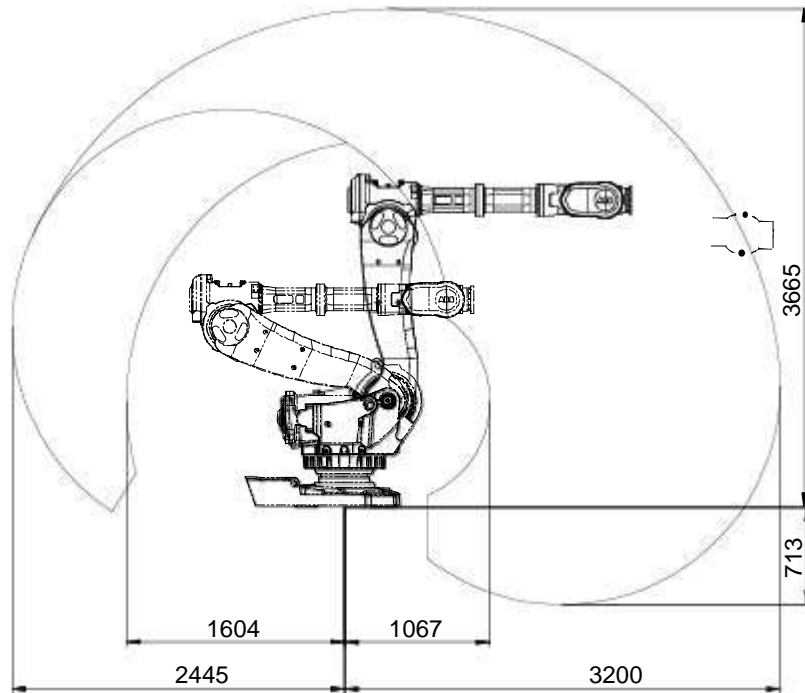

Figure 45 The extreme positions of the robot arm specified at the wrist center (dimensions in mm).

Illustration

Robot Type	Handling capacity (kg)	Reach (m)
IRB 6650	200	2.75
IRB 6650ID	170	2.75

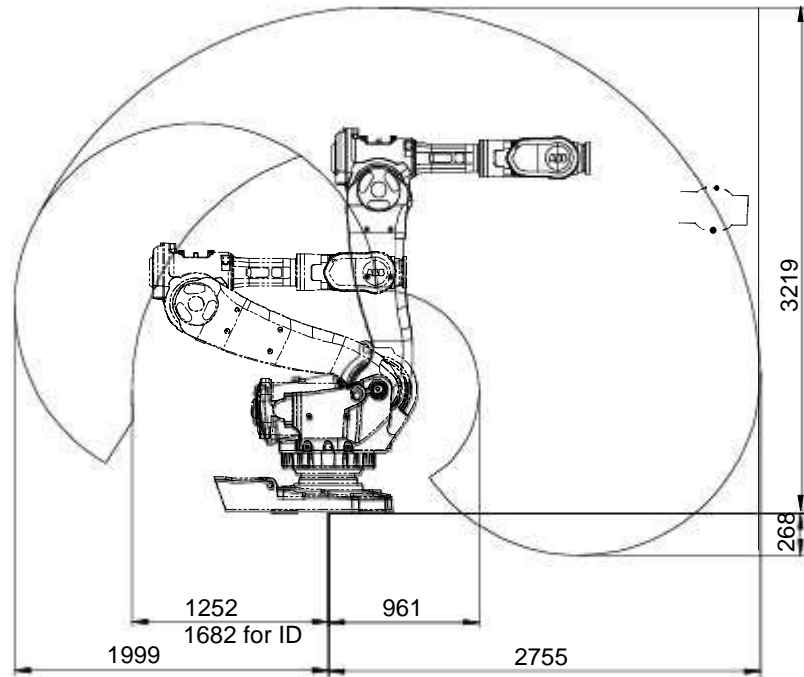

Figure 46 The extreme positions of the robot arm specified at the wrist center (dimensions in mm).

1 Description

1.7.1 Introduction

Illustration

Robot Type	Handling capacity (kg)	Reach (m)
IRB 6650S	200	3.0

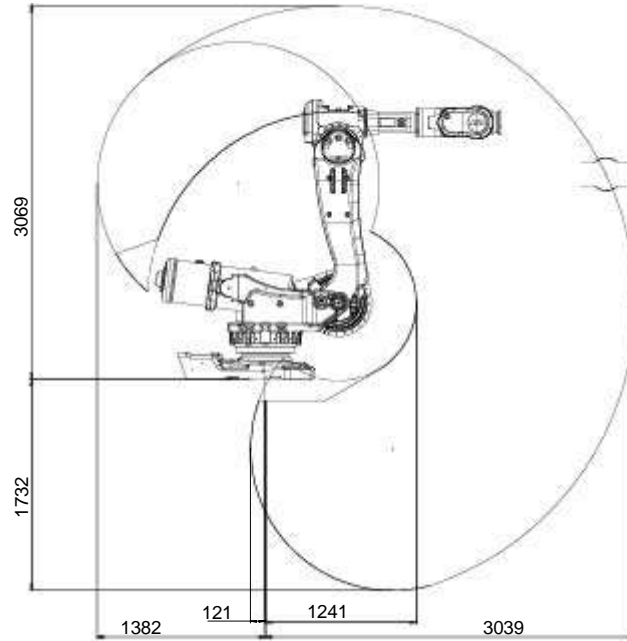

Figure 47 The extreme positions of the robot arm specified at the wrist center (dimensions in mm).

Robot Type	Handling capacity (kg)	Reach (m)
IRB 6650S	125	3.5

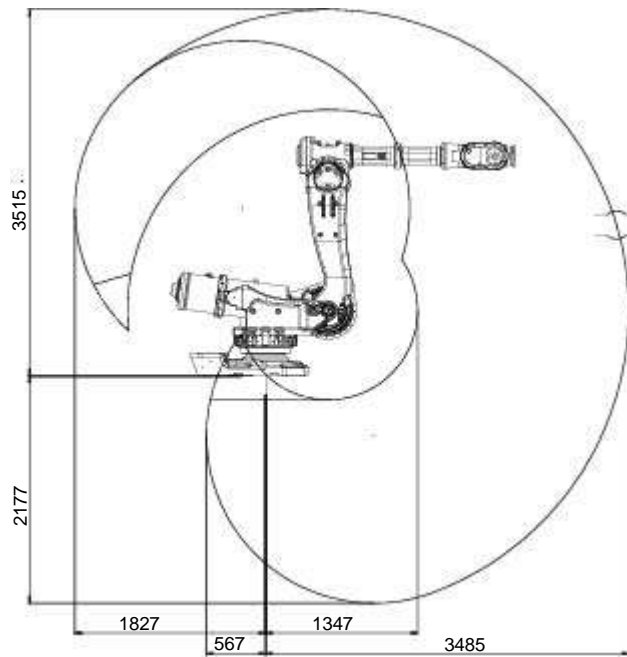

Figure 48 The extreme positions of the robot arm specified at the wrist center (dimensions in mm).

1.7.2 Performance according to ISO 9283

General

At rated maximum load, maximum offset and 1.6 m/s velocity (for IRB 6600-225/2.55, 1.0 m/s velocity) on the inclined ISO test plane, 1 m cube with all six axes in motion.

IRB 6600/6650	175/2.55	225/2.55	175/2.8	125/3.2	200/2.75
Pose accuracy, AP (mm)	0.02-0.09	0.02-0.18	0.03-0.13	0.04-0.11	0.03-0.11
Pose repeatability, RP (mm)	0.08-0.18	0.14-0.28	0.08-0.20	0.10-0.27	0.09-0.29
Pose stabilization time, PSt (s)	0.02-0.03	0.46	0.21	0.30	0.17
Path accuracy, T (mm)	1.96-2.33	3.56	2.25	1.59	2.40
Path repeatability, RT(mm)	0.67-1.05	0.22	0.32	0.37	0.38

IRB 6650S	125/3.5	200/3.0
Pose accuracy, AP (mm)	0.16	0.13
Pose repeatability, RP (mm)	0.13	0.14
Pose stabilization time, PSt (s)	0.33	0.18
Path accuracy, T (mm)	0.82	0.67
Path repeatability, RT(mm)	0.90	0.70

The values for IRB 6600ID - 185/2.55 and IRB 6650ID - 170/2.75 are not yet available.

The above values are the range of average test results from a number of robots.

1 Description

1.7.3 Velocity

1.7.3 Velocity

Maximum axis speeds

Robot Type	Axis 1	Axis 2	Axis 3	Axis 4	Axis 5	Axis 6
IRB 6600-175/2.55	100°/s	90°/s	90°/s	150°/s	120°/s	190°/s
IRB 6600-225/2.55	100°/s	90°/s	90°/s	150°/s	120°/s	190°/s
IRB 6600-175/2.8	100°/s	90°/s	90°/s	150°/s	120°/s	190°/s
IRB 6650-200/2.75	100°/s	90°/s	90°/s	150°/s	120°/s	190°/s
IRB 6650S-200/3.0	100°/s	90°/s	90°/s	150°/s	120°/s	190°/s
IRB 6650-125/3.2	110°/s	90°/s	90°/s	150°/s	120°/s	235°/s
IRB 6650S-125/3.5	110°/s	90°/s	90°/s	150°/s	120°/s	235°/s
IRB 6600ID-185/2.55	100°/s	90°/s	90°/s	150°/s	120°/s	190°/s
IRB 6650ID-170/2.75	100°/s	90°/s	90°/s	150°/s	120°/s	190°/s

There is a supervision function to prevent overheating in applications with intensive and frequent movements.

Axis Resolution

0.001° to 0.005°.

1.8 Cooling fan for axis 1-3 motor

1.8.1 Introduction

Option 87-1, 88-1, 89-1

A motor of the robot needs a fan to avoid overheating if the average speed over time exceeds the value given in the table below. The maximum allowed average speed depends on the load.

Average Speed

The average speed can be calculated with the following formula:

$$\text{Average speed} = \frac{\text{Total axis movement, number of degrees, in one cycle}}{360 \times \text{cycle time (minutes) incl. waiting time}}$$

Maximum Average Speed

The maximum allowed average speed for axis 1-3 at the maximum ambient temperature of 50°C according to table below. IP 54 for cooling fan. Fan failure stops the robot.

Variant	Maximum average speed axis 1 (rpm)	Maximum average speed axis 2 (rpm)	Maximum average speed axis 3 (rpm)
IRB 6600-175/2.55	8.1 - 10.5	2.4 - 2.6	4.7 - 6.1
IRB 6600-225/2.55	7.8 - 10.1	2.1 - 2.3	3.1 - 4.0
IRB 6600-175/2.8	7.8 - 10.1	2.1 - 2.3	3.1 - 4.0
IRB 6650-125/3.2	4.9 - 6.3	2.1 - 2.3	3.1 - 4.0
IRB 6650-200/2.75	7.8 - 10.1	2.1 - 2.3	3.1 - 4.0
IRB 6650S-125/3.5	7.8 - 10.1	2.1 - 2.3	3.1 - 4.0
IRB 6650S-200/3.0	7.8 - 10.1	2.1 - 2.3	3.1 - 4.0
IRB 6600ID-185/2.55	7.8 - 10.1	2.1 - 2.3	3.1 - 4.0
IRB 6650ID-170/2.75	7.8 - 10.1	2.1 - 2.3	3.1 - 4.0

1 Description

1.9.1 Introduction

1.9 Servo Gun

1.9.1 Introduction

General

The robot can be supplied with hardware and software for control of the following configurations:

- Stationary Gun
- Robot Gun
- Stationary and Robot Gun
- Twin Stationary Guns
- Stationary Gun and Track Motion
- Robot Gun and Track Motion
- Track motion

The specific parts related to the servo motor control for electrical welding guns and for track motion configurations are shown in the conceptual pictures below. The major parts and required options are also stated in the configurations lists below each picture.

The cables for control of the basic robot are shown in the pictures with dotted lines.

1.9.2 Stationary Gun

Illustration

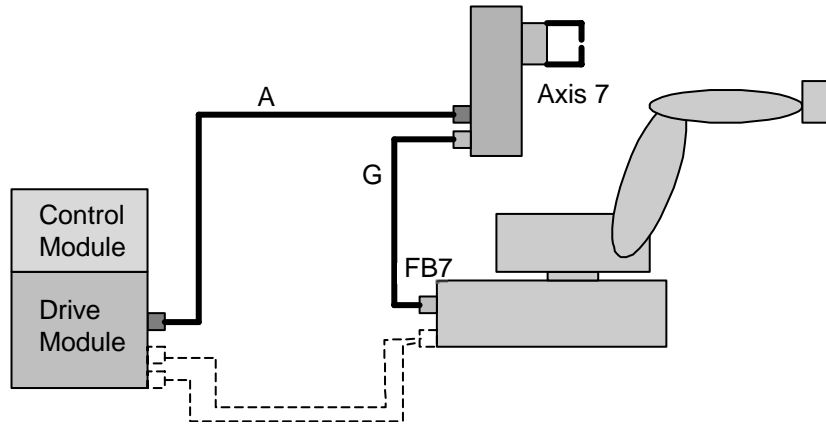

Figure 49 Configuration of Stationary Gun.

Options

Options according to the table below are required to complete the delivery. For further details on each option see corresponding Product Specification.

Option	Description	Product Spec.
785-5	Stationary gun. This option includes: Cable G (7 m length) for resolver signals from robot base (FB7) to stationary gun/axis 7.	
770-4	First additional drive. Drive unit for 7:th axis with corresponding cables assembled inside Drive Module.	Controller, IRC5
786-1,-2,-3,-4	Connection to first drive. Cable A (7-30 m) between Drive Module and stationary gun/axis 7 for servo drive power.	
635-1	Spot Servo. Software for control of a servo gun.	Controller software IRC5

1 Description

1.9.3 Robot Gun

1.9.3 Robot Gun

Illustration

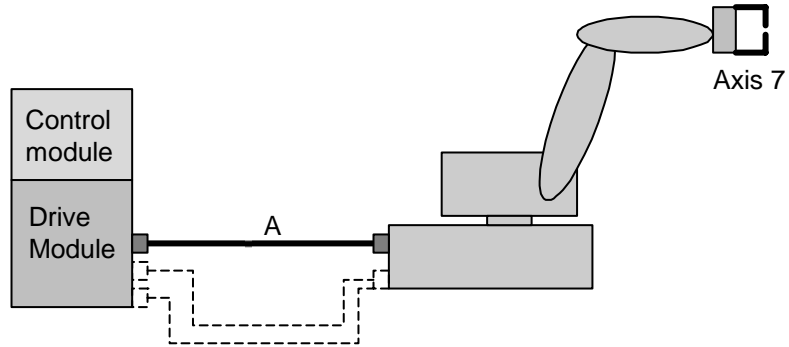

Figure 50 Configuration of Robot Gun.

Options

Options according to table below are required to complete the delivery.
For further details on each option see corresponding Product Specification.

Option	Description	Product Spec.
785-1	Robot gun. This option includes: Cables within manipulator for servo power signals (servo gun/axis 7).	
770-4	First additional drive. Drive unit for 7:th axis with corresponding cables assembled inside Drive Module.	Controller, IRC5
786-1,-2,-3,-4	Connection to first drive. Cable A (7-30 m) between Drive Module and robot base for servo drive power.	
635-1	Spot Servo. Software for control of a servo gun.	Controller software IRC5

1.9.4 Stationary and Robot Gun

Illustration

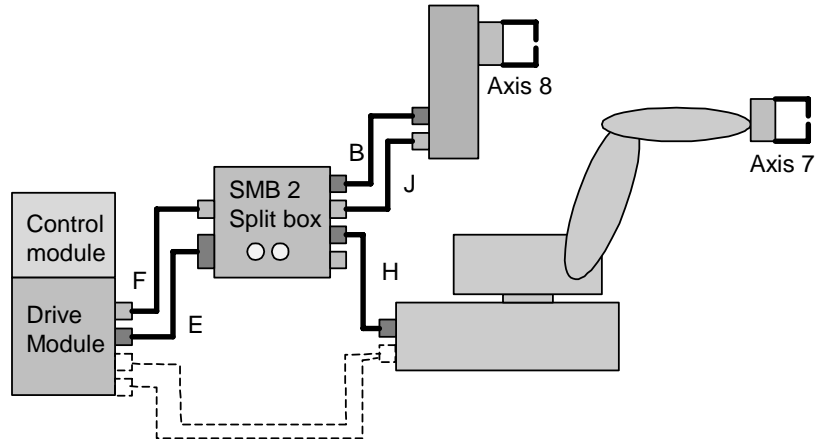

Figure 51 Configuration of Stationary and Robot Gun.

Options

Options according to table below are required to complete the delivery. For further details on each option see corresponding Product Specification.

Option	Description	Product Spec.
785-3	Stationary and Robot gun. This option includes: Cables within manipulator for servo power signals (servo gun/axis 7). Serial measurement box (SMB2, Split box) for distribution of servo power to axis 7 and 8 and resolver signals to axis 8. The box is intended to be placed on stationary gun stand. Cables from serial measurement box to stationary gun/axis 8 and to servo gun/axis 7. Cable B for servo power (1,5 m length). Cable J for resolver signals (1,5 m length). Cable for servo power to robot gun H (7 m length).	
770-4	First additional drive. Drive unit for 7:th axis with corresponding cables assembled inside Drive Module.	Controller, IRC5
771-4	Second additional drive. Drive unit for 8:th axis with corresponding cables assembled inside Drive Module.	Controller, IRC5
787-1,-2,-3,-4	Connection to first and second drive. Cable E and F (7-30 m) between Drive Module and serial measurement box for dual servo drive power/resolver signals.	
635-1	Spot Servo. Software for control of a servo gun.	Controller software IRC5

1 Description

1.9.5 Twin Stationary Guns

1.9.5 Twin Stationary Guns

Illustration

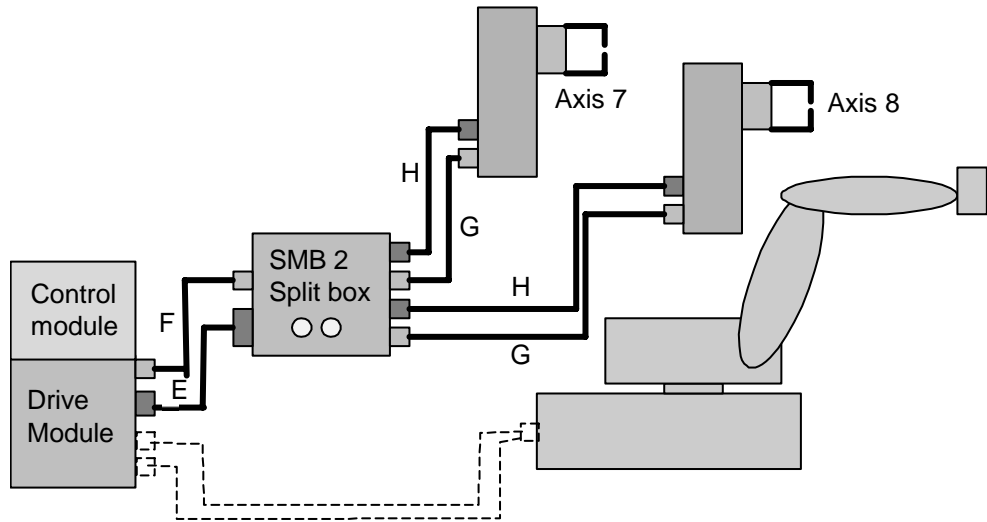

Figure 52 Configuration of Twin Stationary Guns.

Options

Options according to table below are required to complete the delivery. For further details on each option see corresponding Product Specification.

Option	Description	Product Spec.
785-6	Twin Stationary guns. This option includes: Serial measurement box (SMB2, Split box) for distribution of servo power to axis 7 and 8 and resolver signals to axis 7 and 8. The box is intended to be placed on one of the stationary gun stands. Cables from serial measurement box to stationary guns/axis 7 and axis 8. Cables H for servo power (7 m length). Cables G for resolver signals (7 m length).	
770-4	First additional drive. Drive unit for 7:th axis with corresponding cables assembled inside Drive Module.	Controller, IRC5
771-4	Second additional drive. Drive unit for 8:th axis with corresponding cables assembled inside Drive Module.	Controller, IRC5
787-1,-2,-3,-4	Connection to first and second drive. Cable E and F (7-30 m) between Drive Module and serial measurement box for dual servo drive power/resolver signals.	
635-1	Spot Servo. Software for control of a servo gun. (For simultaneous welding Spot Servo Multiple Guns are required).	Controller software IRC5

1.9.6 Stationary Gun and Track Motion

Illustration

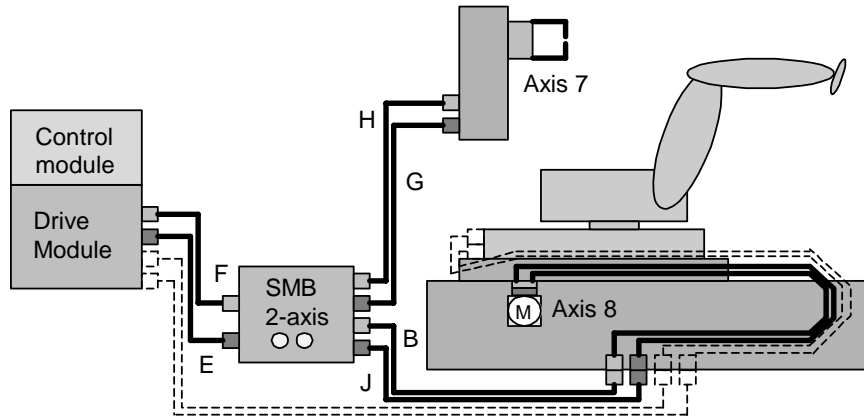

Figure 53 Configuration of Stationary Gun and Track Motion.

Options

Options according to table below are required to complete the delivery.
For further details on each option see corresponding Product Specification.

Option	Description	Product Spec.
785-4	Stationary gun - Track motion. This option includes: Cables from serial measurement box to stationary gun/axis 7. Cable H for servo power (7 m length). Cable G for resolver signals (7 m length).	
Track motion delivery includes	Serial measurement box (SMB2, Split box) for distribution of servo power and resolver signals to axis 7 and 8. The box is placed on the track motion base. Cables from serial measurement box to track motion. Cable B for servo power (1,5 m length). Cable J for resolver signals (1,5 m length).	Track motion IRBT 6003S/ IRBT 7003S
770-4	First additional drive. Drive unit for 7:th axis with corresponding cables assembled inside Drive Module.	Controller, IRC5
771-4	Second additional drive. Drive unit for 8:th axis with corresponding cables assembled inside Drive Module.	Controller, IRC5
787-1,-2,-3,-4	Connection to first and second drive. Cable E and F (7-30 m) between Drive Module and serial measurement box for dual servo drive power/ resolver signals.	
635-1	Spot Servo. Software for control of a servo gun.	Controller software IRC5

1 Description

1.9.7 Robot Gun and Track Motion

1.9.7 Robot Gun and Track Motion

Illustration

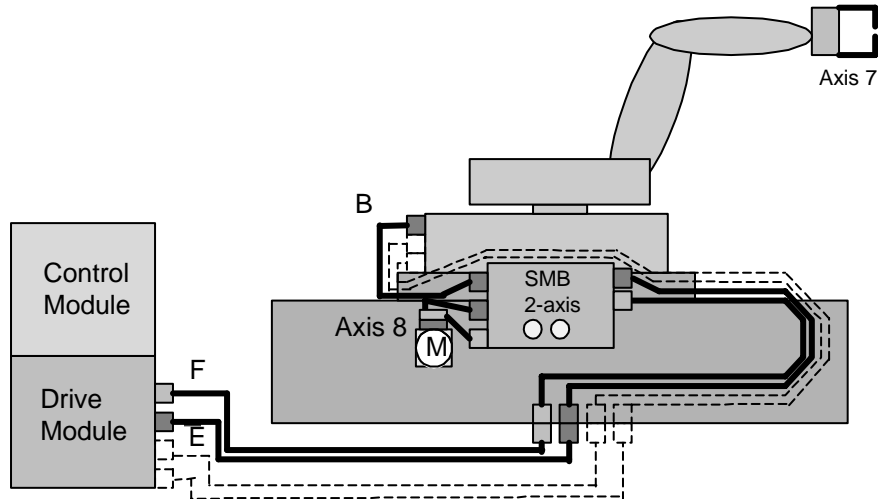

Figure 54 Configuration of Robot Gun and Track Motion.

Options

Options according to table below are required to complete the delivery.
For further details on each option see corresponding Product Specification.

Option	Description	Product Spec.
785-2	Robot Gun - Track Motion. This option includes: Cables within manipulator for servo power signals (servo gun/axis 7).	
Track motion delivery includes	Serial measurement box (SMB2, Split box) for distribution of servo power and resolver signals to axis 7 and 8. The box is placed on the track motion. Cables from serial measurement box to track motion. Cable B for servo power (1,5 m length).	Track motion IRBT 6003S/ IRBT 7003S
770-4	First additional drive. Drive unit for 7:th axis with corresponding cables assembled inside Drive Module.	Controller, IRC5
771-4	Second additional drive. Drive unit for 8:th axis with corresponding cables assembled inside Drive Module.	Controller, IRC5
787-1,-2,-3,-4	Connection to first and second drive. Cable E and F (7-30 m) between Drive Module and serial measurement box for dual servo drive power/resolver signals.	
635-1	Spot Servo. Software for control of a servo gun.	Controller software IRC5

1.9.8 Track Motion

General

The robot can be supplied with a Track Motion, see Product Specification IRBT 6003S. For configuration and specification of hardware see Figure 55.

Illustration

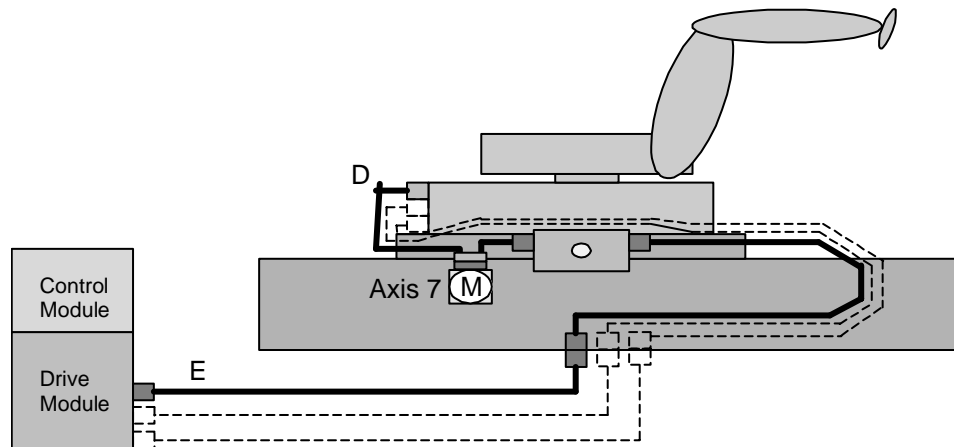

Figure 55 Configuration of Track Motion.



General. The robot can be combined with a Track Motion, for further details see Product Specification IRBT 6003S/IRBT 7003S.

Options

Options according to table below are required to complete the delivery. For further details on each option see corresponding Product Specification.

Option	Description	Product Spec.
Track motion delivery includes	Serial measurement box (SMB, Split box) for distribution of servo power signals to axis 7/Track motion. The box is placed on the track. Cable D for resolver signals (1,5 m length). From robot base to serial measurement box. Cable E for between Drive Module and track motion servo for drive power.	Track motion IRBT 6003S/ IRBT 7003S
770-4	First additional drive. Drive unit for 7:th axis with corresponding cables assembled inside Drive Module.	

1 Description

1.9.8 Track Motion

2 SpotPack and DressPack

2.1 Introduction

2.1.1 General

The different robot types can be equipped with the SpotPack or DressPack options. The SpotPack is designed for spot welding and handling applications. The function package supplies the transformer gun or the robot gripper with necessary media, such as compressed air, cooling water and electrical power.

The SpotPack contains the modules shown in Figure 56 below.

Details for the modules within DressPack are shown in Figure 57 and Figure 58.

Illustration SpotPack

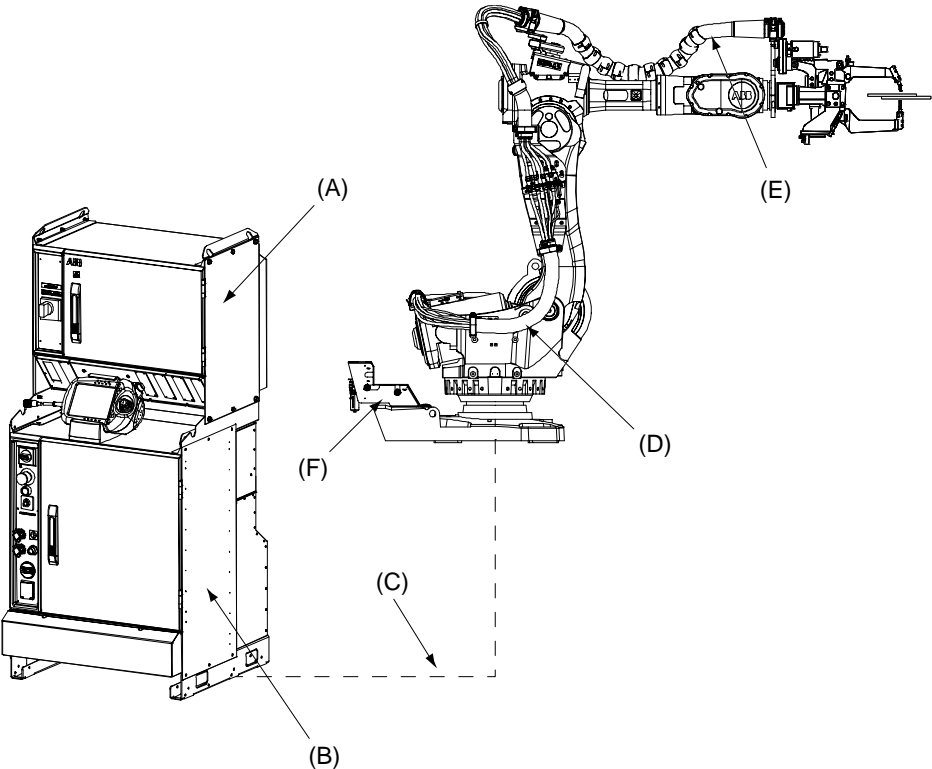

Figure 56 SpotPack modules M2004.

Pos.	Name
A	SpotWelding cabinet
B	Robot Cabinet IRC5
C	DressPack, Floor
D	DressPack, Lower arm
E	DressPack, Upper arm
F	Water and Air unit with hoses

2 SpotPack and DressPack

2.1.1 General

Illustration DressPack

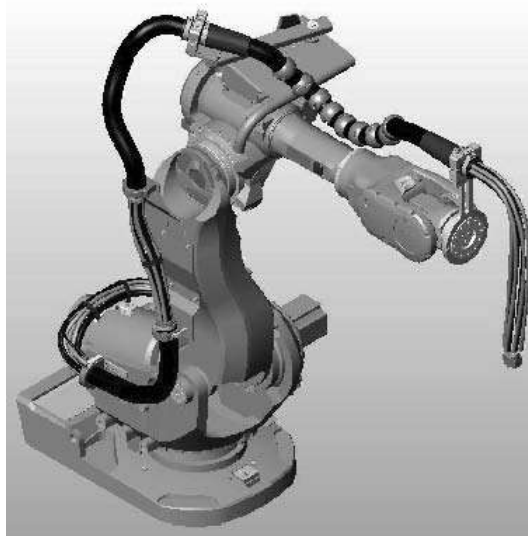

Figure 57 "Orange line" (option 798-2).

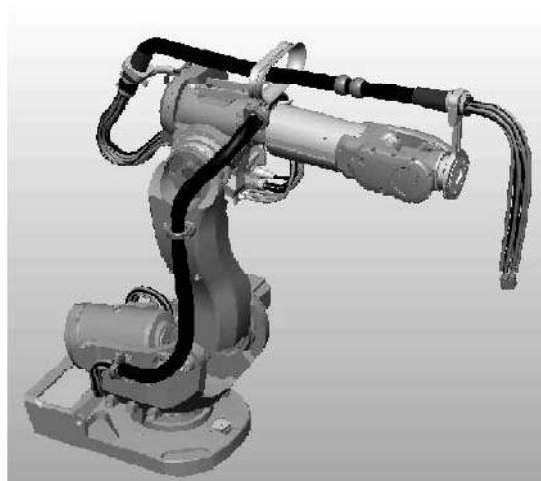

Figure 58 "Silver line" (option 798-1).

2.1.2 Chapter Structure

The Chapters for SpotPack and DressPack are structured in the following way.

The SpotPack and DressPack can be delivered in five versions developed for two different applications. Each type is described under separate chapter.

Chapter	Option	Description
2.2	DressPack	DressPack includes general description DressPack with common information.

Material Handling application / DressPack

Chapter	Option	Description
2.3	Type H	Designed for Material Handling.

SpotWelding application / SpotPack and DressPack

Chapter	Option	Description
2.4	Type S	Designed for pneumatic transformer guns carried by the robot manipulator.
2.5	Type HS	Designed for handling the part against pneumatic transformer guns stationary mounted.
2.6	Type Se	Designed for electrical servo driven transformer guns carried by the robot manipulator.
2.7	Type HSe	Designed for handling the part against electrical servo driven transformer guns stationary mounted.
2.8	SpotWelding Cabinet	Includes general description of SpotWelding cabinet with common information.
2.9	Water and Air unit	Includes general description of Water and Air unit with common information.
2.10	Connection Kits	Includes general description of Connection kits for SpotPack and DressPack.

2.2 DressPack

2.2.1 Introduction

General

Dress Pack includes options for Upper arm, Lower arm and Floor see Figure 56 pos. C, D and E. These are described separated below but are designed as a complete package for various applications.

The DressPack for the floor contains customer signals.

The DressPack for upper and lower arm contains process cable packages including signals, process media (water and/or air) and power feeding (for SpotWelding power) for customer use.

Necessary supports and brackets are also included.

The routing of the process cable package on the robot is available in different configurations. There are two main alternatives named the “Silver line” and the “Orange line” to divide them. Brackets and retractor arm for “Silver line” are mainly done in metallic color and for the “Orange line” the main color is orange.

For the upper arm there are also internal routing alternatives for some of the manipulator variants.

DressPack lower arm

For the Material Handling application there are two internal routing alternatives for the lower arm. The “Orange line” is shown in Figure 59 below. This is designed to fit to the upper arm “Orange line” routing. The alternative “Silver line” is shown in Figure 60.

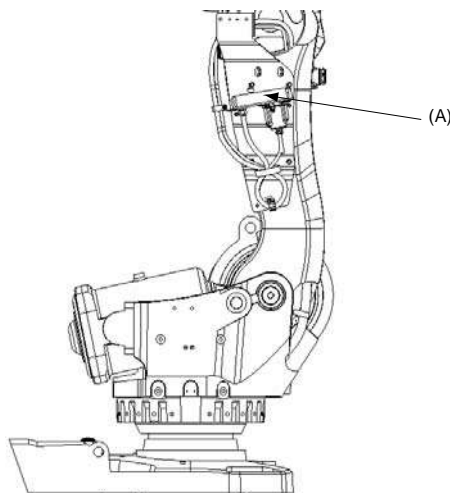

Figure 59 .“Orange line” DressPack Lower arm right side view Material Handling version (option 778-1 and option 798-2).

Pos	Description
A	Connection point

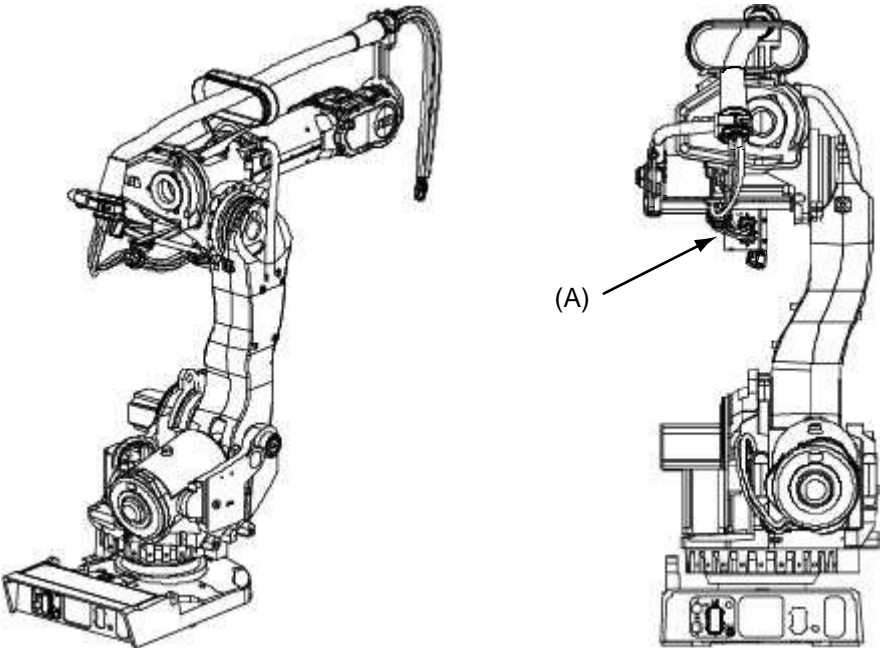

Figure 60 “Silver line” DressPack Lower arm left side view Material Handling (option 778-1 and option 798-1).

Pos	Description
A	Connection point

For SpotWelding application there are also two external routing alternatives for the lower arm. The “Orange line” is shown in Figure 61 below. This is designed to fit to the upper arm “Orange line” routing. The alternative “Silver line” is shown in Figure 62.

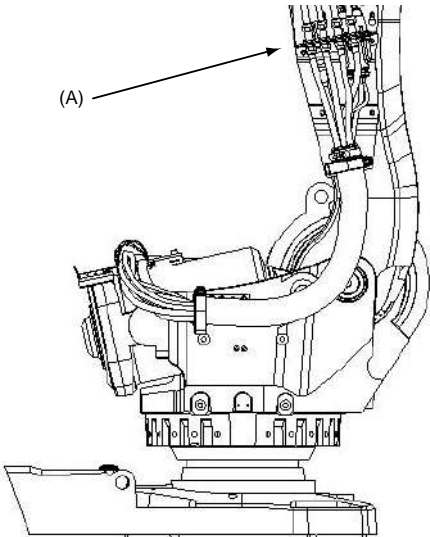

Figure 61 “Orange line” DressPack Lower arm left side view SpotWelding (option 778-2 and option 798-2).

Pos	Description
A	Connection point

2 SpotPack and DressPack

2.2.1 Introduction

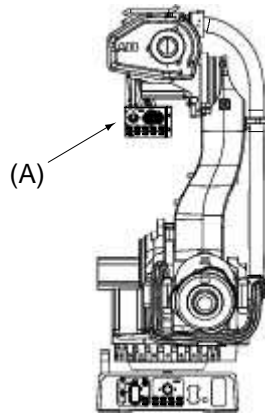

Figure 62 “Silver line” DressPack Lower arm rear side view SpotWelding (option 778-2 and option 798-1).

Pos	Description
A	Connection point

DressPack Upper arm

For the Material Handling and SpotWelding application there are three alternatives for the upper arm. Two of the alternatives are external. The “Orange line” is shown in Figure 63 below and the alternative “Silver line” is shown in Figure 64. The internal routing is shown in Figure 65.

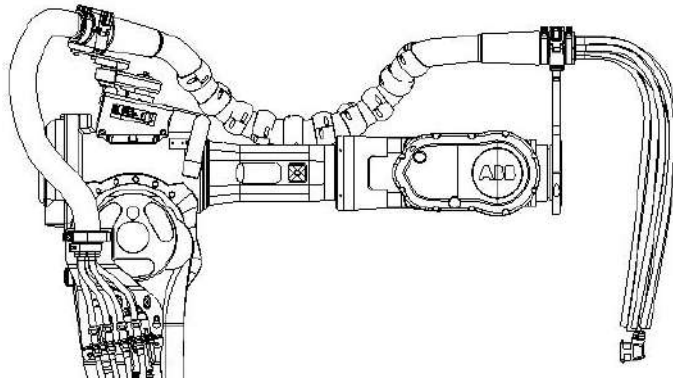

Figure 63 “Orange line” DressPack Upper arm right arm side view SpotWelding version (option 778-2, option 780-2 and option 798-2).

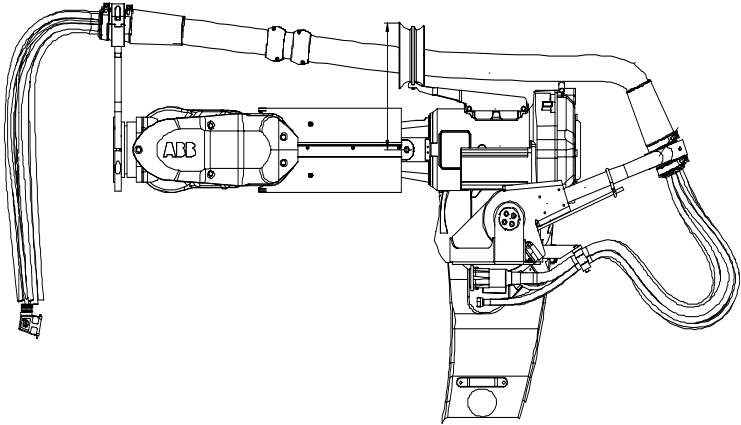

Figure 64 "Silver line" DressPack Upper arm left arm side view SpotWelding version (option 778-2, option 780-2 and option 798-1).

Picture to be completed later

Figure 65 Internal routing. DressPack right Upper arm side view SpotWelding (option 778-2, option 780-1 and option 798-2).

DressPack Upper arm/Lower arm

For SpotWelding application within "Orange line" there is one additional alternative without connection point between lower and upper arm available.



Figure 66 "Orange line" DressPack Upper/Lower arm SpotWelding (option 778-2, option 781-1 and option 798-2).

2 SpotPack and DressPack

2.2.1 Introduction

External process cable package

The external process cable package for both “Orange and Silver line” has a 1000-mm free length at axis 6 for connection to a robot tool. The retractor arm unit keeps hose package close to the robot upper arm.

The external DressPack Upper arm part has the following main features:

- Adjustable bracket axis 6 with position marking.
- Adjustable retracting force to optimise the system depending on cycle and hose package.
- Hose guiding to support large working range.

For more information see the Installation and Service Manual SpotPack and DressPack.

The DressPack Lower arm part has a connection point at the manipulator base. The configuration, which is valid both for “Orange and Silver line”, is shown in Figure 67 below.

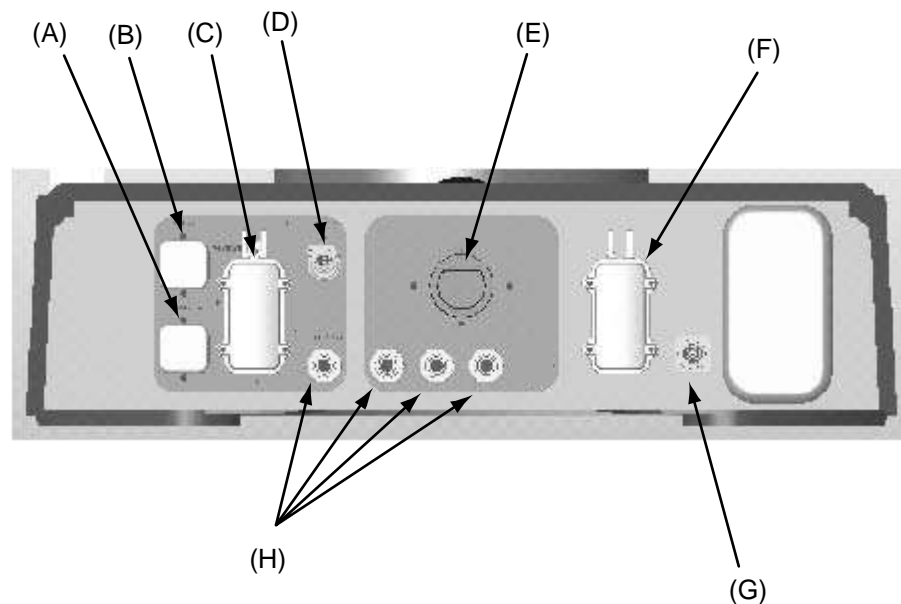

Figure 67 Connection point at base.

Pos	Description
A	R1.SW2/3
B	R1.SW1
C	R1.CP/CS
D	R3.FB7 or R1.SP (SpotWelding Servo gun)
E	R1.WELD 3x35mm ² . (SpotWelding)
F	R1.MP
G	R1.SMB
H	R1.PROC 1 (Material Handling/SpotWelding 1/2", M22x1.5, 24 degree seal) R1.PROC 2-4 (SpotWelding 1/2", M22x1.5, 24 degree seal)

The DressPack floor has a connection point inside the robot controller where connections can be made to terminals. This configuration is valid both for “Orange and Silver line”.

Dimensions for external routing with “Orange line” and “Silver line” are shown in Figure 68, Figure 69, Figure 73 and Figure 74. Dimensions for internal routing (6600ID-185/2.55 and 6650ID-170/2.75) are shown in Figure 70, Figure 71 and Figure 72. All routing alternatives are shown in the SpotWelding version.

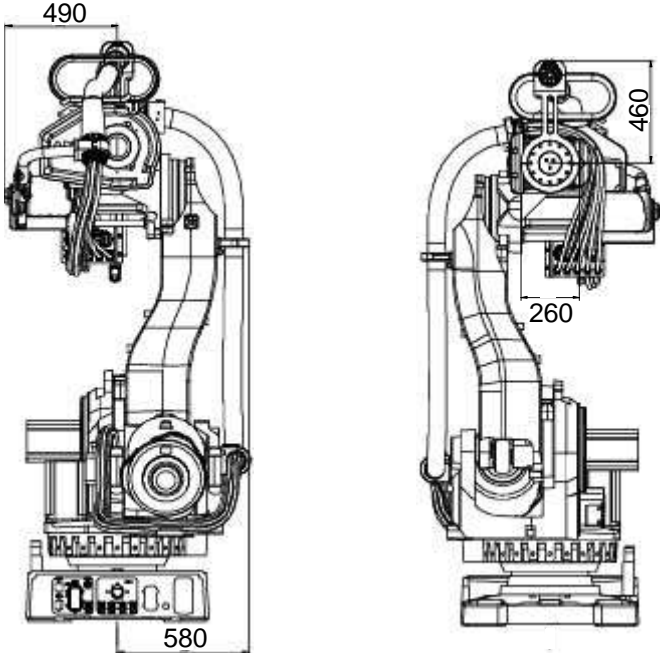

Figure 68 “Silver line”, external routing (Dimensions in mm).

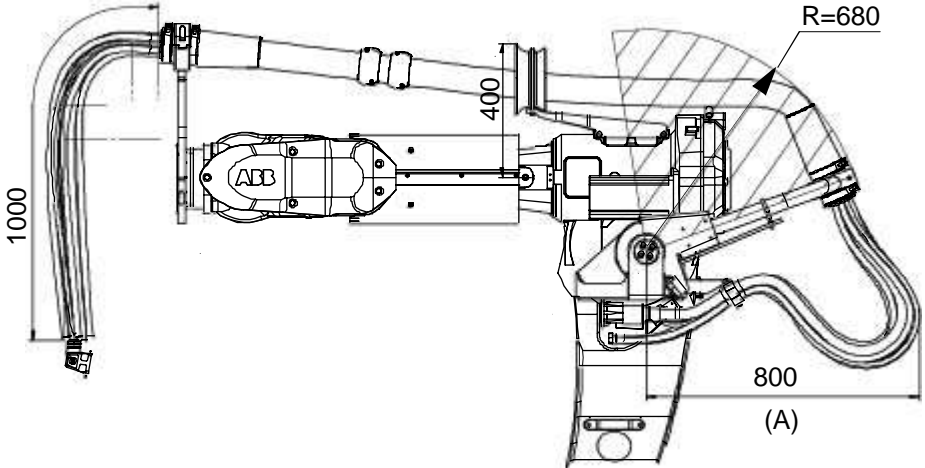

Figure 69 “Silver line”, external routing (Dimensions in mm).

Pos	Description
A	Maximum distance for hose package.

Picture to be completed later

Figure 70 Front and back view. Internal routing.

Picture to be completed later

Figure 71 Right side view. Internal routing.

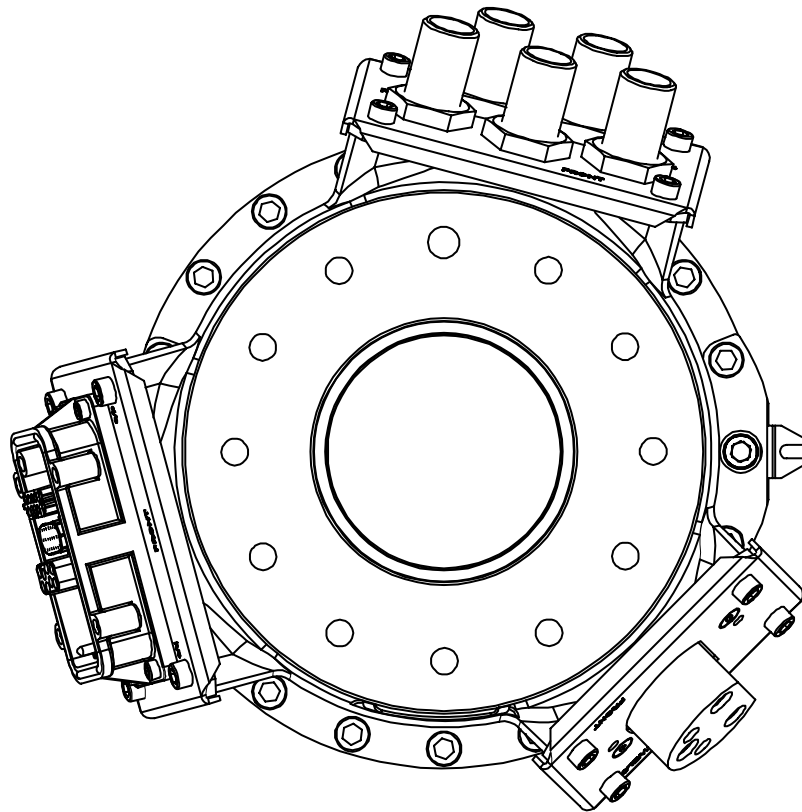

Figure 72 Detailed view for axis 6. Internal routing.

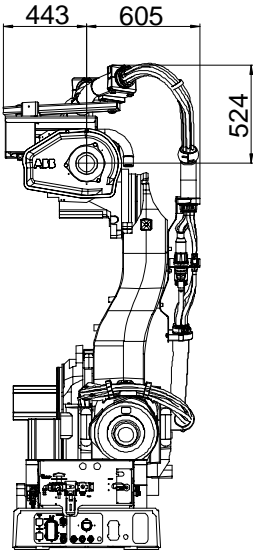

Figure 73 "Orange line", external routing (Dimensions in mm).

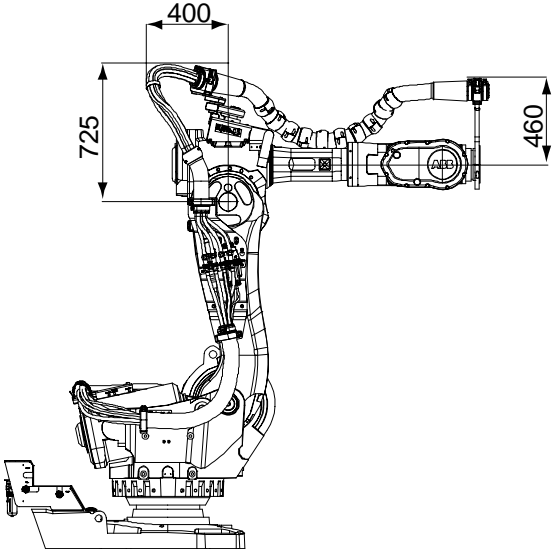

Figure 74 "Orange line", external routing (Dimensions in mm).

2.3 Type H

2.3.1 Introduction

General

Variant Type H is designed for Material Handling (MH) application. Included modules are shown in Figure 75.

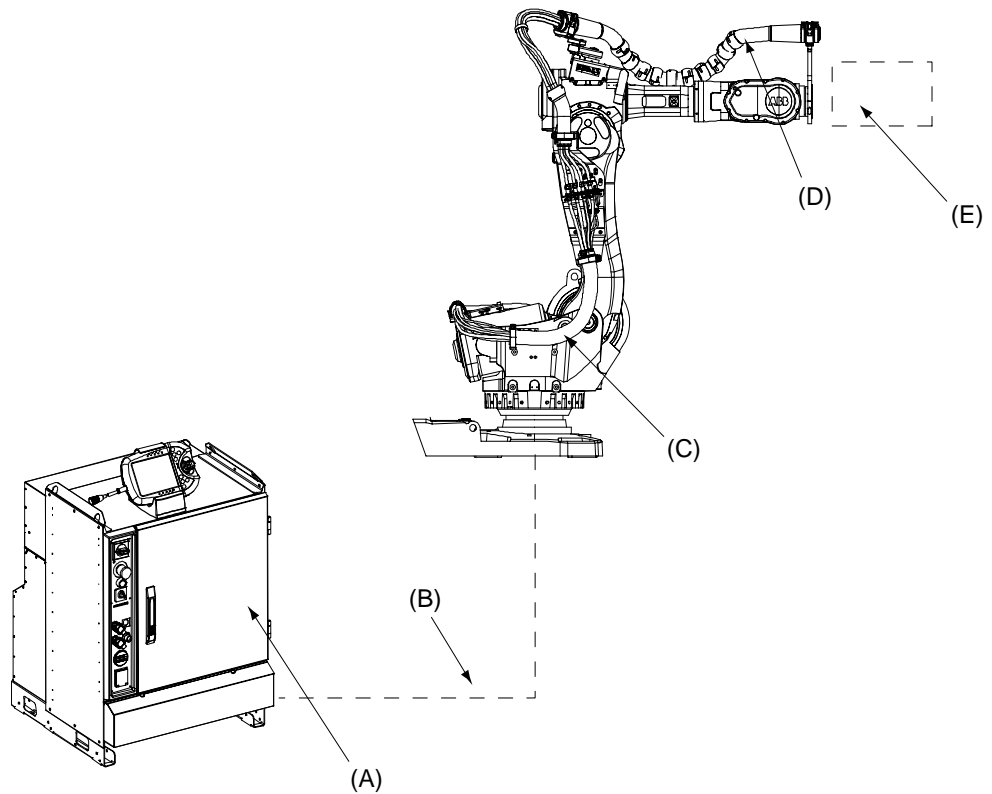

Figure 75 Dresspack shown with "Orange line" configurations.

Pos.	Name
A	Robot Cabinet IRC5
B	DressPack, Floor
C	DressPack, Lower arm
D	DressPack, Upper arm
E	Robot Gripper

Available configurations with linked option numbers are described below.

Option description

Option	Type	Description
16-2	Connection to manipulator	No Floor harness for the DressPack is chosen.
16-1	Connection to cabinet	Floor cables and connections inside the I/O section for the DressPack are chosen. The length and configuration of the floor harness is specified under the options below. Option 94-1,-2,-3,-4 for parallel communication. Option 90-2,-3,-4,-5 for parallel communication and field bus communication with Can/DeviceNet. Option 92-2,-3,-4,-5 for parallel communication and field bus communication with Profibus. Option 91-2,-3,-4,-5 for parallel communication and field bus communication with Interbus.
455-1	Parallel communication	Offers the signal cables needed for parallel communication in lower and upper arm DressPack. To be combined with option 94-1,-2,-3,-4,-5.
455-4	Parallel and Bus communication	Offers the signal cables needed for the combination of parallel and bus communication in lower and upper arm DressPack. To be combined with option 90-2,-3,-4,-5 or 92-2,-3,-4,-5 or 91-2,-3,-4,-5.

- Option 778-1. for the application Material Handling.
- Option 798-1. Internal routing, (Silver line). Offers DressPack Lower arm for Material Handling application with internal routing according to “Silver line”.
- Option 798-2. Internal routing, (Orange line). Offers DressPack Lower arm for Material Handling application with internal routing according to “Orange line”.
- Option 780-2 and option 798-1. External routing, (Silver line). Offers DressPack upper arm for Material Handling application with external routing according to “Silver line”.
- Option 780-2 and option 798-2. External routing, (Orange line). Offers DressPack upper arm for Material Handling application with external routing according to “Orange line”.
- Option 780-1 and option 798-2. Internal routing, (Orange line) offers DressPack Upper arm for Material Handling application with internal routing.

The available alternatives and allowed combinations are shown in the schematic Figure 76 below.

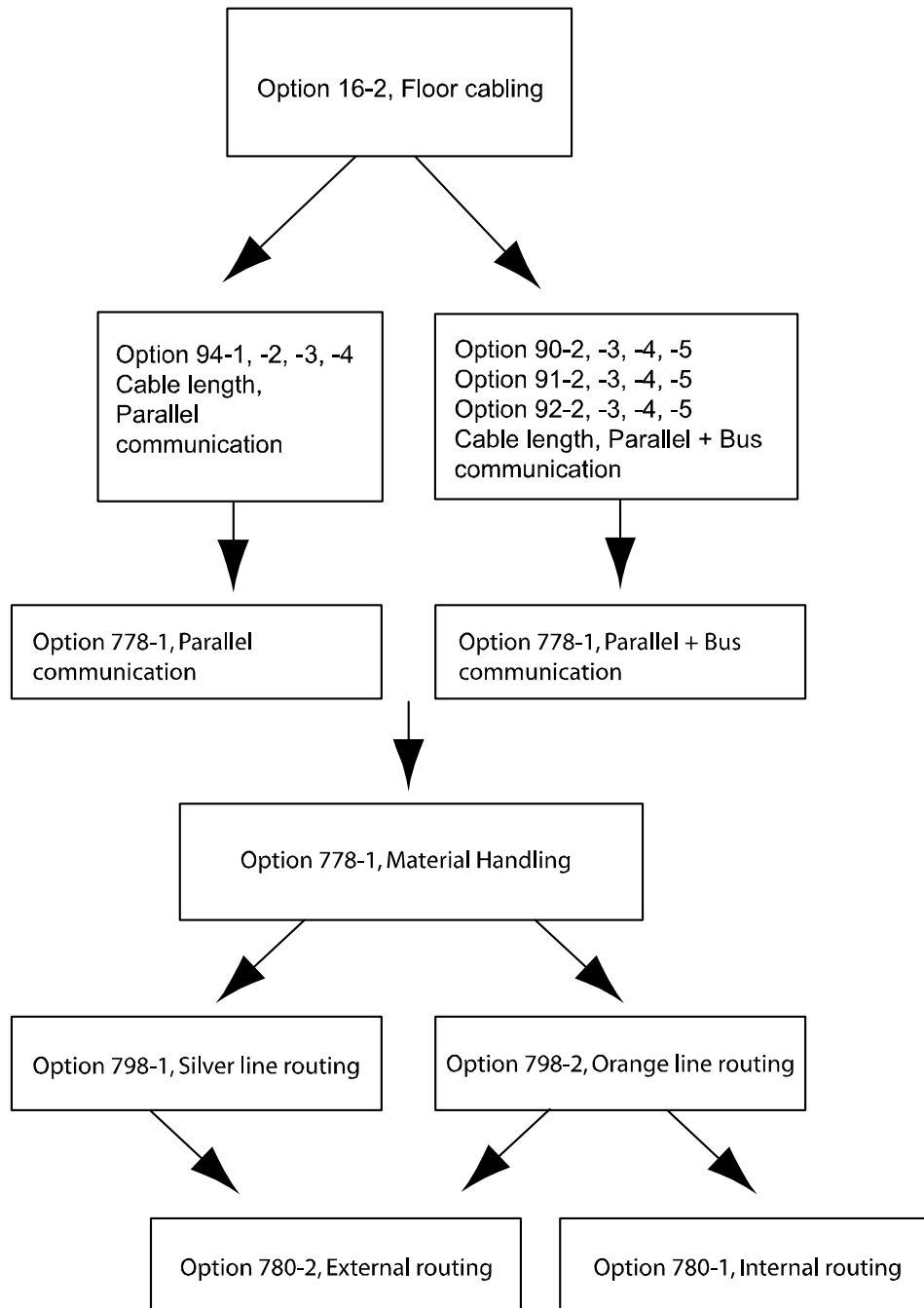

Figure 76 Schematic picture for configuration of DressPack for Material Handling application.

2.3.2 Configuration result for Type H

General

Depending on the choice of options above the DressPack will have different content. The choice of routing (“Silver line” or “Orange line”) will not affect the content. See tables for signal content below.

DressPack Type H. Parallel communication

- Option 16-2 or Option 16-1 with Connection to cabinet (option 94-1,-2,-3,-4 to specify cable length)
- Option 455-1 Parallel communication
- Option 778-1 Material Handling
- Option 798-1 or Option 798-2. Internal routing, DressPack Lower arm

One of the options:

- Option 780-2 (and Option 798-1 or Option 798-2). External routing, or
- Option 780-1 (and Option 798-2) Internal routing, DressPack Upper arm

The table below is showing available type of wires/media.

Type	At terminals in cabinet	At Connection point. Base, Axis 2/3 or axis 6	Cable/part area	Allowed capacity
Customer Power (CP)				
Utility Power	2+2	2+2	0,5 mm ²	250 VAC, 5 A rms
Protective earth		1	0,5 mm ²	250 VAC
Customer Signals (CS)				
Signals twisted pair	20	20 (10x2) ^a	0,23 mm ²	50 V DC, 1 A rms
Signals twisted pair and separate shielded	8	8 (4x2)	0,23 mm ²	50 V DC, 1 A rms
Media				
Air (PROC 1)		1	12,5 mm inner diameter	Max. Air pressure 16 bar/230 PSI ^b

a. For IRB 6600/6650 ID 16 signals instead of 20 signals.

b. For IRB 6600/6650 ID Max. air pressure 12 bar.

2 SpotPack and DressPack

2.3.2 Configuration result for Type H

DressPack Type H. Parallel and field bus communication, Can/DeviceNet

- Option 16-2 or Option 16-1 with Connection to cabinet (Option 90-2,-3,-4,-5 to specify cable length)
- Option 455-4. Parallel and bus communication
- Option 778-1. Material Handling
- Option 798-1 or Option 798-2. Internal routing, DressPack Lower arm

One of the options:

- Option 780-2 (and Option 798-1 or Option 798-2). External routing, or
- Option 780-1 (and Option 798-2) Internal routing, DressPack Upper arm

The table below is showing available type of wires/media.

Type	At terminals in cabinet	At Connection point. Base, Axis 2/3 or axis 6	Cable/part area	Allowed capacity
Customer Power (CP)				
Utility Power	2+2	2+2	0,5 mm ²	250 VAC, 5 A rms
Protective earth		1	0,5 mm ²	250 VAC
Customer Signals (CS)				
Signals twisted pair	20	20 (10x2) ^a	0,23 mm ²	50 V DC, 1 A rms
Signals twisted pair and separate shielded	8	8 (4x2)	0,23 mm ²	50 V DC, 1 A rms
Customer bus (CBus)				
Bus signals	At bus board	2	0,14 mm ²	Can/DeviceNet spec
Bus signals	At bus board	2	0,23 mm ²	50 V DC, 1 A rms
Signals twisted pair	6	6(3x2)	0,14 mm ²	50 V DC, 1 A rms
Media				
Air (PROC 1)		1	12,5 mm inner diameter	Max. Air pressure 16 bar/230 PSI ^b

a. For IRB 6600/6650 ID 16 signals instead of 20 signals.

b. For IRB 6600/6650 ID Max. air pressure 12 bar.

DressPack Type H. Parallel and field bus communication, Profibus

- Option 16-2 or Option 16-1 with Connection to cabinet (Option 92-2,-3,-4,-5 to specify cable length)
- Option 455-4 Parallel and bus communication
- Option 778-1 Material Handling
- Option 798-1 or Option 798-2. Internal routing, DressPack Lower arm

One of the options:

- Option 780-2 (and Option 798-1 or Option 798-2). External routing, or
- Option 780-1 (and Option 798-2) Internal routing, DressPack Upper arm

The table below is showing available type of wires/media.

Type	At terminals in cabinet	At Connection point. Base, Axis 2/3 or axis 6	Cable/part area	Allowed capacity
Customer Power (CP)				
Utility Power	2+2	2+2	0,5 mm ²	250 VAC, 5 A rms
Protective earth		1	0,5 mm ²	250 VAC
Customer Signals (CS)				
Signals twisted pair	22	22 (11x2) ^a	0,23 mm ²	50 V DC, 1 A rms
Signals twisted pair and separate shielded	8	8 (4x2)	0,23 mm ²	50 V DC, 1 A rms
Customer bus (CBus)				
Bus signals	At bus board	2	0,14 mm ²	Profibus 12 Mbit/s spec
Signals twisted pair	6	6 (3x2)	0,14 mm ²	50 V DC, 1 A rms
Media				
Air (PROC 1)		1	12,5 mm inner diameter	Max. Air pressure 16 bar/230 PSI ^b

a. For IRB 6600/6650 ID 18 signals instead of 22 signals.

b. For IRB 6600/6650 ID Max. air pressure 12 bar.

2 SpotPack and DressPack

2.3.2 Configuration result for Type H

DressPack Type H. Parallel and field bus communication, Interbus

- Option 16-2 or Option 16-1 with Connection to cabinet (Option 91-2,-3,-4,-5 to specify cable length)
- Option 455-4 Parallel and bus communication
- Option 778-1 Material Handling
- Option 798-1 or Option 798-2. Internal routing, DressPack Lower arm

One of the options:

- Option 780-2 (and Option 798-1 or Option 798-2). External routing, or
- Option 780-1 (and Option 798-2) Internal routing, DressPack Upper arm

The table below is showing available type of wires/media.

Type	At terminals in cabinet	At Connection point. Base, Axis 2/3 or axis 6	Cable/part area	Allowed capacity
Customer Power (CP)				
Utility Power	2+2	2+2	0,5 mm ²	250 VAC, 5 A rms
Protective earth		1	0,5 mm ²	250 VAC
Customer Signals (CS)				
Signals twisted pair	21	21 (10x2+1) ^a	0,23 mm ²	50 V DC, 1 A rms
Signals twisted pair and separate shielded	8	8 (4x2)	0,23 mm ²	50 V DC, 1 A rms
Customer bus (CBus)				
Bus signals	At bus board	4	0,14 mm ²	Interbus spec
Bus signals	At bus board	1	0,23 mm ²	50 V DC, 1 A rms
Signals twisted pair	4	4 (2x2)	0,14 mm ²	50 V DC, 1 A rms
Media				
Air (PROC 1)		1	12,5 mm inner diameter	Max. Air pressure 16 bar/230 PSI ^b

a. For IRB 6600/6650 ID 17 signals instead of 21 signals.

b. For IRB 6600/6650 ID Max. air pressure 12 bar.

2.3.3 Interface description DressPack for Type H

General

The interface at axis 6 has a hose ending with free end for external routing and a fitting for internal routing. The signal cables end with a signal connector type modular Harting. The connector configurations are described in the table below. Signals with (parentheses) are to be connected by customer inside the robot control cabinet.

Connection

Name	Communication types			
	Parallel	Parallel and Can DeviceNet	Parallel and Interbus	Parallel and Profibus
Harting module type at axis 6	HD+DD+EE	HD+DD+EE	HD+DD+EE	HD+DD+EE

Customer power signals

Name	Sep. screened	Terminal in cabinet	Pin no at base	Pin no at axis 2/3	Pin no at axis 6	Communication types			
						Parallel	Parallel and Can Device Net	Parallel and Interbus	Parallel and Profibus
(+24 V)		XP6 / 1	D1	D1	C4	Yes	Yes	Yes	Yes
(0 V)		XP6 / 2	D6	D6	C5	Yes	Yes	Yes	Yes
(+24 V)		XP6 / 3	D3	D3	C6	Yes	Yes	Yes	Yes
(0 V)		XP6 / 4	D4	D4	C7	Yes	Yes	Yes	Yes
PE (in housing)			GND	GND	GND	Yes	Yes	Yes	Yes

Customer signals

Name	Sep. screened	Terminal in cabinet	Pin no at base	Pin no at axis 2/3	Pin no at axis 6	Communication types			
						Parallel	Parallel and Can Device Net	Parallel and Interbus	Parallel and Profibus
(Spare)		XP5:1/1	B1	B1	B18	Yes	Yes	Yes	Yes
(Spare)		XP5:1/2	B2	B2	B19	Yes	Yes	Yes	Yes
(Spare)	X	XP5:2/1	B3	B3	B20	Yes	Yes	Yes	Yes
(Spare)	X	XP5:2/2	B4	B4	B21	Yes	Yes	Yes	Yes

2 SpotPack and DressPack

2.3.3 Interface description DressPack for Type H

Name	Sep. screened	Terminal in cabinet	Pin no at base	Pin no at axis 2/3	Pin no at axis 6	Communication types			
						Parallel	Parallel and Can Device Net	Parallel and Interbus	Parallel and Profibus
(Spare)	X	XP5:2/3	B5	B5	B22	Yes	Yes	Yes	Yes
(Spare)	X	XP5:2/4	B6	B6	B23	Yes	Yes	Yes	Yes
(Spare)	X	XP5:1/9	B7	B7	B24	Yes	Yes	Yes	Yes
(Spare)	X	XP5:1/10	B8	B8	B25	Yes	Yes	Yes	Yes
(Spare)	X	XP5:1/11	B9	B9	B16	Yes	Yes	Yes	Yes
(Spare)	X	XP5:1/12	B10	B10	B17	Yes	Yes	Yes	Yes
(Spare)		XP5:1/3	B11	B11	B1	Yes	Yes	Yes	Yes
(Spare)		XP5:1/4	B12	B12	B2	Yes	Yes	Yes	Yes
(Spare)		XP5:1/5	B13	B13	B3	Yes	Yes	Yes	Yes
(Spare)		XP5:1/6	B14	B14	B4	Yes	Yes	Yes	Yes
(Spare)		XP5:3/1	B15	B15	B5	Yes	Yes	Yes	Yes
(Spare)		XP5:3/2	B16	B16	B6	Yes	Yes	Yes	Yes
(Spare)		XP5:3/3	B18	B18	B7	Yes	Yes	Yes	Yes
(Spare)		XP5:3/4	B19	B19	B8	Yes	Yes	Yes	Yes
(Spare)		XP5:3/5	B20	B20	B9	Yes	Yes	Yes	Yes
(Spare)		XP5:3/6	B21	B21	B10	Yes	Yes	Yes	Yes
(Spare)		XP5:2/5	C16	C16	B11 ^a	not used	Yes	Yes	Yes
(Spare)		XP5:2/6	C17	C17	B12 ¹	not used	Yes	Yes	Yes
(Spare)		XP5:2/7	C18	C18	B13 ¹	Yes	Yes	Yes	Yes
(Spare)		XP5:1/7	C19	C19	B14	Yes	Yes	Yes	Yes
(Spare)		XP5:2/8	C20	C20	B15 ¹	Yes	Yes	Yes	Yes
(Spare)		XP5:1/8	C21	C21	C8	Yes	Yes	Yes	Yes

a. Not connected at IRB 6600/6650 ID.

Cbus signals

Name	Sep. screened	Terminal in cabinet	Pin no at base	Pin no at axis 2/3	Pin no at axis 6	Communication types			
						Parallel	Parallel and Can Device Net	Parallel and Interbus	Parallel and Profibus
(Spare) or Bus signal		See comm. types	B22	B22	A1	XP5:2/9	+24V Can	GNDIM	XP5:2/9
(Spare) or Bus signal		See comm. types	B23	B23	A2	XP5:2/10	0V Can	XP5:2/10	XP5:2/10

Name	Sep. screened	Terminal in cabinet	Pin no at base	Pin no at axis 2/3	Pin no at axis 6	Communication types			
						Parallel	Parallel and Can Device Net	Parallel and Interbus	Parallel and Profibus
(Spare) or Bus signal		See comm. types	B24	B24	A3	XP5:2/11	XP5:2/11	XP5:2/11	XP5:2/11
(Spare) or Bus signal		See comm. types	B25	B25	A4	XP5:2/12	XP5:2/12	XP5:2/12	XP5:2/12
(Spare) or Bus signal		See comm. types	A9	A9	A5	not used	XP5:3/9	DO	XP5:3/9
(Spare) or Bus signal		See comm. types	A10	A10	A6	not used	XP5:3/10	DO_N	XP5:3/10
(Spare) or Bus signal		See comm. types	A3	A3	A7	not used	Can_H	XP5:3/9	XP5:3/7
(Spare) or Bus signal		See comm. types	A4	A4	A8	not used	Can_L	XP5:3/10	XP5:3/8
(Spare) or Bus signal		See comm. types	A5	A5	A9	not used	XP5:3/7	XP5:3/7	RXD/ TXD-P
(Spare) or Bus signal		See comm. types	A6	A6	A10	not used	XP5:3/8	XP5:3/8	RXD/ TXD-N
(Spare) or Bus signal		See comm. types	A11	A11	A11	not used	XP5:3/11	DI	XP5:3/11
(Spare) or Bus signal		See comm. types	A12	A12	A12	not used	XP5:3/12	DI_N	XP5:3/12

2 SpotPack and DressPack

2.3.3 Interface description DressPack for Type H

Harting Connector - External routing

The Harting connector for external routing is shown in the Figure 77. The different main parts within the connector are described in the list below, both with name and Harting article number. (Corresponding parts at the tool are available with a Connection kit (see chapter 2.10 Connection kits.) and within the Harting product offer).

Name	Harting article no.
Hood	09 30 010 0543
Hinged frame, hood	09 14 010 0303
Multicontact, female (HD) (25 pin)	09 14 025 3101
Multicontact, female (EE) (12 pin)	09 14 008 3101
Multicontact, female (DD) (8 pin)	09 14 012 3101

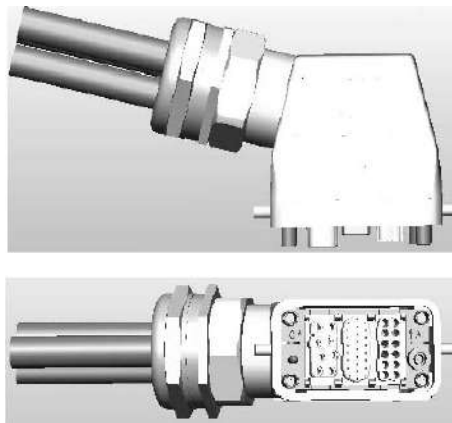

Figure 77 Harting connector external routing.

Harting connector - Internal routing

Name	Harting article no.
Hood	09 62 040 0301
Multicontact, female (HD) (25 pin)	09 14 025 3101
Multicontact, female (EE) (12 pin)	09 14 008 3101
Multicontact, female (DD) (8 pin)	09 14 012 3101

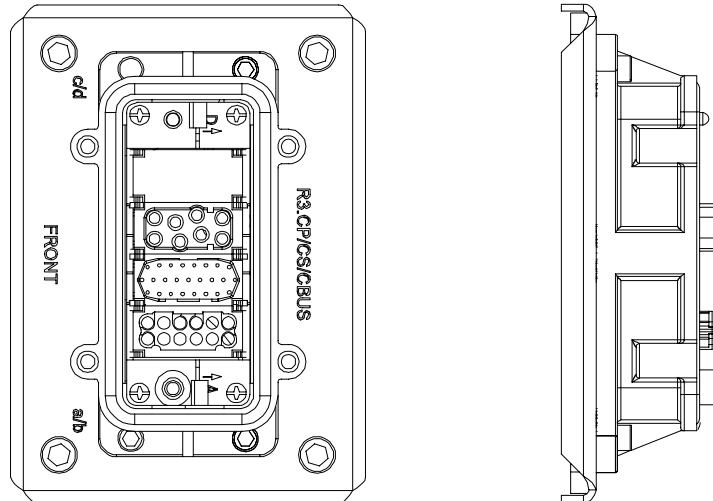

Figure 78 Harting connector for internal routing.

Hose fitting, Internal routing

- For the internal routing the hose ends with fitting type: Parker Pushlock, (½", M22x1,5 Brass, 24 degree seal).

2.3.4 Summary Type H**DressPack**

The following options are required to form a complete DressPack Type H:

- Option 16-1 Connection to cabinet, (Cable length and communication type to be stated)
- Option 455-1, 455-4 Parallel or Parallel and Bus communication (Communication type to be stated)
- Option 778-1 Material Handling
- Option 798-1 or Option 798-2 Internal routing, DressPack Lower arm (Routing type to be stated)
- Option 780-2 External routing or option 780-1 Internal routing, DressPack Upper arm (Routing type to be stated)

2 SpotPack and DressPack

2.4.1 Introduction

2.4 Type S

2.4.1 Introduction

General

Variant Type S is designed for SpotWelding application with robot handled pneumatic gun. Included modules are shown in Figure 79. Available configurations with linked option numbers are described below.

Illustration SpotPack

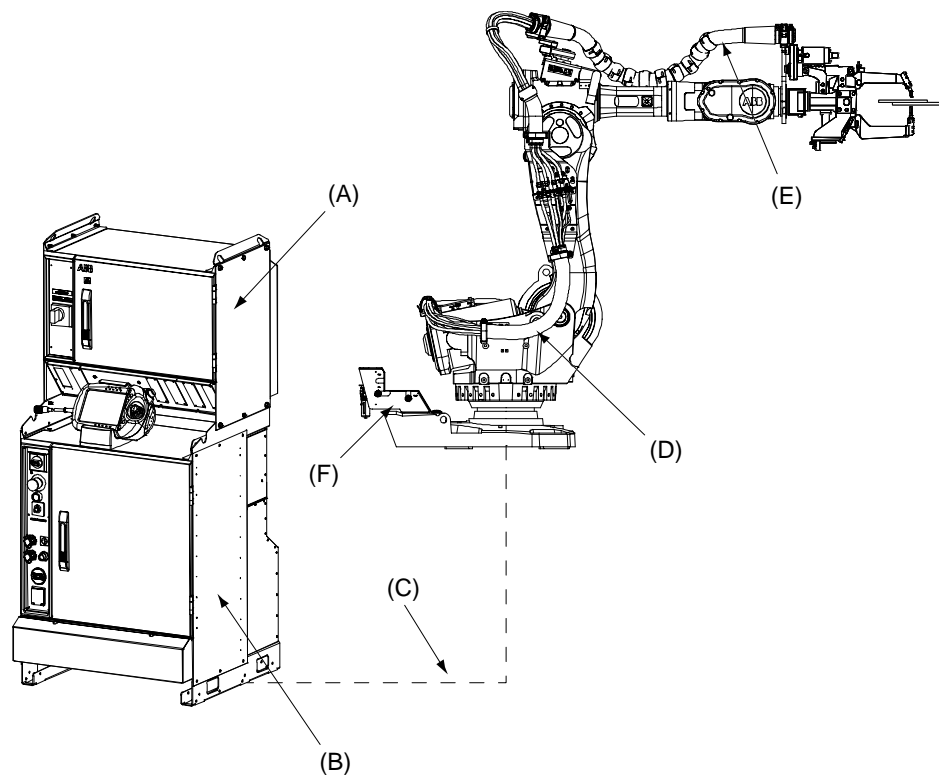

Figure 79 Type S shown with "Orange line" DressPack.

Pos.	Name
A	SpotWelding cabinet
B	Robot Cabinet IRC5
C	DressPack, Floor
D	DressPack, Lower arm
E	DressPack, Upper arm
F	Water and Air unit with hoses

Available configurations and allowed combinations with linked option numbers are described below.

Option Description

Option	Type	Description
16-2	Connection to manipulator	No Floor harness for the DressPack is chosen.
16-1	Connection to cabinet	Floor cables and connections inside the I/O section for the DressPack are chosen. The length and configuration of the floor harness is specified under the options below. Option 94-1,-2,-3,-4 for parallel communication Option 90-2,-3,-4,-5 for parallel communication and field bus communication with Can/DeviceNet Option 92-2,-3,-4,-5 for parallel communication and field bus communication with Profibus Option 91-2,-3,-4,-5 for parallel communication and field bus communication with Interbus
455-1	Parallel communication	Offers the signal cables needed for parallel communication in lower and upper arm DressPack. To be combined with option 94-1,-2,-3,-4.
455-4	Parallel and Bus communication	Offers the signal cables needed for the combination of parallel and bus communication in combination in lower and upper arm DressPack. To be combined with option 90-2,-3,-4,-5 or 92-2,-3,-4,-5 or 91-2,-3,-4,-5.

- Option 778-2. for the application SpotWelding.
- Option 798-1. External routing, (Silver line). Offers DressPack Lower arm for SpotWelding application with external routing according to “Silver line”.
- Option 798-2. External routing, (Orange line). Offers DressPack Lower arm for SpotWelding application with external routing according to “Orange line”.
- Option 780-2 and option 798-1. External routing, (Silver line). Offers DressPack Upper arm for SpotWelding application with external routing according to “Silver line”.
- Option 780-2 and option 798-2. External routing, (Orange line). Offers DressPack Upper arm for SpotWelding application with external routing according to “Orange line”.
- Option 781-1 And option 798-2. Routing base to axis 6. External routing (Orange line). Offers DressPack Lower and Upper arm external routing without intermediate connection point.
- Option 780-1 and option 798-2. Internal routing. Offers DressPack Upper arm for SpotWelding application with internal routing.

The available alternatives and allowed combinations are shown in the schematic Figure 80 below.

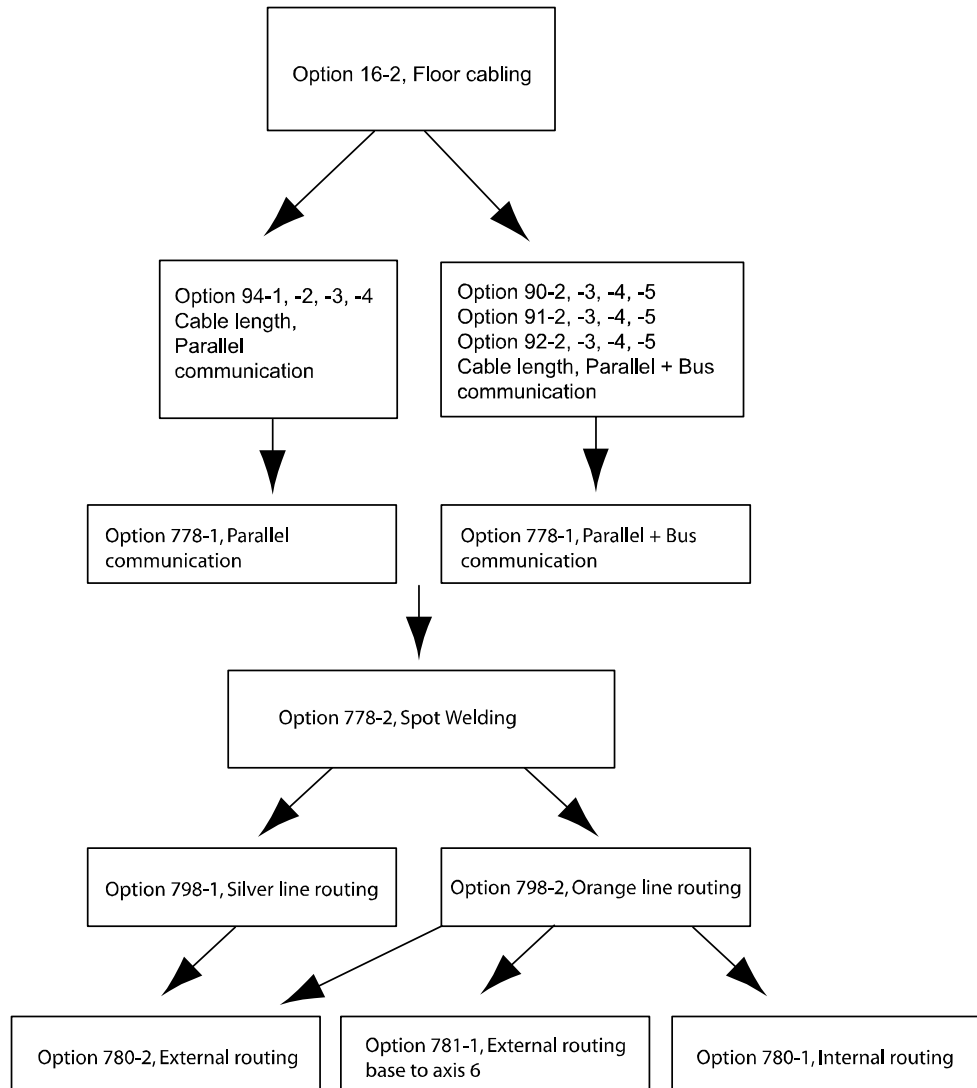

Figure 80 Schematic picture for configuration of DressPack for SpotWelding application.

2.4.2 Configuration result for Type S

General

Depending on the choice of options above the DressPack will have different content. The choice of routing (“Silver line” or “Orange line”) will not affect the content. See tables for signal content below.

DressPack Type S. Parallel communication

- Option 16-2 or 16-1 with Connection to cabinet (option 94-1,-2,-3,-4 to specify cable length)
- Option 455-1 Parallel communication
- Option778-2 SpotWelding
- Option 798-1 or Option 798-2 External routing, DressPack Lower arm

One of the options:

- Option 780-2 (and Option 798-1 or Option 798-2) External routing, DressPack Upper arm, or
- Option 780-1 (and option 798-2) Internal routing, DressPack Upper arm, or
- Option 781-1 (and Option 798-2). Routing base to axis 6

The table below is showing available type of wires/media.

Type	At terminals in cabinet	At connection point. Base, axis 2/3 or axis 6	Cable/part area	Allowed capacity
Customer Power (CP) Utility Power Protective earth	2+2	2+2 1	0,5 mm ² 0,5 mm ²	250 VAC, 5 A rms 250 VAC
Customer Signals (CS) Signals twisted pair	20	20 (10x2) ^a	0,23 mm ²	50 V DC, 1 A rms
Signals twisted pair and separate shielded	8	8 (4x2)	0,23 mm ²	50 V DC, 1 A rms
Media Water/Air (PROC 1-4)		4	12,5 mm inner diameter	Max. air pressure 16 bar/ 230 PSI ^b Max water pressure 10 bar/ 145 PSI
Welding power (WELD) Lower and Upper arm Protective earth (Lower and Upper arm)		2 1	35 mm ² 35 mm ²	600 VAC, 150 A rms at 20°C (68°F)

a. For IRB 6600/6650 ID 16 signals instead of 20 signals.

b. For IRB 6600/6650 ID Max. air pressure 12 bar.

2 SpotPack and DressPack

2.4.2 Configuration result for Type S

DressPack Type S. Parallel and field bus communication, Can/DeviceNet

- Option 16-2 or Options 16-1 with Connection to cabinet (Option 90-2,-3,-4,-5 to specify cable length)
- Option 455-4 Parallel and bus communication
- Option 778-2 SpotWelding
- Option 798-1 or Option 798-2 External routing, DressPack Lower arm

One of the options:

- Option 780-2 (and Option 798-1 or Option 798-2) External routing, or
- Option 780-1 (and Option 798-2) Internal routing, DressPack Upper arm, or
- Option 781-1 (and Option 798-2). Routing base to axis 6

The table below is showing available type of wires/media.

Type	At terminals in cabinet	At connection point. Base, axis 2/3 or axis 6	Cable/part area	Allowed capacity
Customer Power (CP)				
Utility Power	2+2	2+2	0,5 mm ²	250 VAC, 5 A rms
Protective earth		1	1 mm ²	250 VAC
Customer signals (CS)				
Signals twisted pair	20	20 (10x2) ^a	0,23 mm ²	50 V DC, 1 A rms
Signals twisted pair and separate shielded	8	8 (4x2)	0,23 mm ²	50 V DC, 1 A rms
Customer bus (CBus)				
Bus signals	At bus board	2	0,14 mm ²	Can/DeviceNet spec
Bus signals	At bus board	2	0,23 mm ²	50 V DC, 1 A rms
Signals twisted pair	6	6 (3x2)	0,14 mm ²	50 V DC, 1 A rms
Media				
Water/Air (PROC 1-4)		4	12,5 mm inner diameter	Max. Air pressure 16 bar/230 PSI ^b Max. Water pressure 10 bar/145 PSI.
Welding power (WELD)				
Lower and Upper arm		2	35 mm ²	600 VAC, 150 A rms at 20°C (68°F)
Protective earth (Lower and Upper arm)		1	35 mm ²	

a. For IRB 6600/6650 ID 16 signals instead of 20 signals.

b. For IRB 6600/6650 ID Max. air pressure 12 bar.

DressPack Type S. Parallel and field bus communication, Profibus

- Option 16-2 or Options 16-1 with Connection to cabinet (Option 92-2,-3,-4,-5 to specify cable length)
- Option 455-4 Parallel and bus communication
- Option 778-2 SpotWelding
- Option 798-1 or Option 798-2 External routing, DressPack Lower arm

One of the options:

- Option 780-2 (and Option 798-1 or Option 798-2) External routing, or
- Option 780-1 (and Option 798-2) Internal routing, DressPack Upper arm, or
- Option 781-1 (and Option 798-2). Routing base to axis 6

The table below is showing available type of wires/media.

Type	At terminals in cabinet	At connection point. Base, axis 2/3 or axis 6	Cable/part area	Allowed capacity
Customer Power (CP)				
Utility Power	2+2	2+2	0,5 mm ²	250 VAC, 5 A rms
Protective earth		1	0,5 mm ²	250 VAC
Customer signals (CS)				
Signals twisted pair	22	22 (11x2) ^a	0,23 mm ²	50 V DC, 1 A rms
Signals twisted pair and separate shielded	8	8 (4x2)	0,23 mm ²	50 V DC, 1 A rms
Customer bus (CBus)				
Bus signals	At bus board	2	0,14 mm ²	Profibus 12 Mbit/s spec
Signals twisted pair	6	6 (3x2)	0,14 mm ²	50 V DC, 1 A rms
Media				
Water/Air (PROC 1-4)		4	12,5 mm inner diameter	Max. Air pressure 16 bar/230 PSI ^b Max. Water pressure 10 bar/145 PSI.
Welding power (WELD)				
Lower and Upper arm		2	35 mm ²	600 VAC, 150 A rms at 20°C (68°F)
Protective earth (Lower and Upper arm)		1	35 mm ²	

a. For IRB 6600/6650 ID 18 signals instead of 22 signals.

b. For IRB 6600/6650 ID Max. air pressure 12 bar.

2 SpotPack and DressPack

2.4.2 Configuration result for Type S

DressPack Type S. Parallel and field bus communication, Interbus

- Option 16-2 or Options 16-1 with Connection to cabinet (Option 91-2,-3,-4,-5 to specify cable length)
- Option 455-4 Parallel and bus communication
- Option 778-2 SpotWelding
- Option 798-1 or Option 798-2 External routing, DressPack Lower arm

One of the options:

- Option 780-2 (and Option 798-1 or Option 798-2) External routing, or
- Option 780-1 (and Option 798-2) Internal routing, DressPack Upper arm, or
- Option 781-1 (and Option 798-2). Routing base to axis 6

The table below is showing available type of wires/media.

Type	At terminals in cabinet	At connection point. Base, axis 2/3 or axis 6	Cable/part area	Allowed capacity
Customer Power (CP)				
Utility Power	2+2	2+2	0,5 mm ²	250 VAC, 5 A rms
Protective earth		1	0,5 mm ²	250 VAC
Customer signals(CS)				
Signals twisted pair	21	21 (10x2+1) ^a	0,23 mm ²	50 V DC, 1 A rms
Signals twisted pair and separate shielded	8	8 (4x2)	0,23 mm ²	50 V DC, 1 A rms
Customer bus (CBus)				
Bus signals	At bus board	4	0,14 mm ²	Interbus spec
Bus signals	At bus board	1	0,23 mm ²	50 V DC, 1 A rms
Signals twisted pair	4	4 (2x2)	0,14 mm ²	50 V DC, 1 A rms
Media				
Water/Air (PROC 1-4)		4	12,5 mm inner diameter	Max. Air pressure 16 bar/230 PSI ^b Max. Water pressure 10 bar/145 PSI.
Welding power (WELD)				
Lower and Upper arm		2	35 mm ²	600 VAC, 150 A rms at 20°C (68°F)
Protective earth (Lower and Upper arm)		1	35 mm ²	

a. For IRB 6600/6650 ID 17 signals instead of 21 signals.

b. For IRB 6600/6650 ID Max. air pressure 12 bar.

2.4.3 Interface description DressPack for Type S

Customer Interface

The DressPack interface at axis 6 has a connector type modular Harting for the signals. For external routing the hoses and the weld cable have free ends. For the internal routing the weld cable ends with a connector and the hoses end with fittings. The connector configurations are described in the tables below. Signals with (parentheses) are to be connected by customer inside the robot control cabinet.

Name	Communication types			
	Parallel	Parallel and Can DeviceNet	Parallel and Interbus	Parallel and Profibus
Harting module type at axis 6	HD+DD+EE	HD+DD+EE	HD+DD+EE	HD+DD+EE

Customer power signals

Name	Sep. screened	Terminal in cabinet	Pin no at base	Pin no at axis 2/3	Pin no at axis 6	Communication types			
						Parallel	Parallel and Can Device Net	Parallel and Interbus	Parallel and Profibus
+24 V		XP6 / 1	D1	D1	C4	Yes	Yes	Yes	Yes
0 V		XP6 / 2	D6	D6	C5	Yes	Yes	Yes	Yes
+24 V		XP6 / 3	D3	D3	C6	Yes	Yes	Yes	Yes
0 V		XP6 / 4	D4	D4	C7	Yes	Yes	Yes	Yes
PE (in housing)			GND	GND	GND	Yes	Yes	Yes	Yes

Customer signals

Name	Sep. screened	Terminal in cabinet	Pin no at base	Pin no at axis 2/3	Pin no at axis 6	Communication types			
						Parallel	Parallel and Can Device Net	Parallel and Interbus	Parallel and Profibus
gl_open_hlift/ (Spare)		XP5:1/1	B1	B1	B18	Yes	Yes	Yes	Yes
gl_close_hlift/ (Spare)		XP5:1/2	B2	B2	B19	Yes	Yes	Yes	Yes
(Spare)	X	XP5:2/1	B3	B3	B20	Yes	Yes	Yes	Yes

2 SpotPack and DressPack

2.4.3 Interface description DressPack for Type S

Name	Sep. screened	Terminal in cabinet	Pin no at base	Pin no at axis 2/3	Pin no at axis 6	Communication types			
						Parallel	Parallel and Can Device Net	Parallel and Interbus	Parallel and Profibus
(Spare)	X	XP5:2/2	B4	B4	B21	Yes	Yes	Yes	Yes
(Spare)	X	XP5:2/3	B5	B5	B22	Yes	Yes	Yes	Yes
(Spare)	X	XP5:2/4	B6	B6	B23	Yes	Yes	Yes	Yes
KSR	X	XP5:1/9	B7	B7	B24	Yes	Yes	Yes	Yes
KSR	X	XP5:1/10	B8	B8	B25	Yes	Yes	Yes	Yes
(Spare)	X	XP5:1/11	B9	B9	B16	Yes	Yes	Yes	Yes
(Spare)	X	XP5:1/12	B10	B10	B17	Yes	Yes	Yes	Yes
gl_close_gun/ (Spare)		XP5:1/3	B11	B11	B1	Yes	Yes	Yes	Yes
gl_gun_open/ (Spare)		XP5:1/4	B12	B12	B2	Yes	Yes	Yes	Yes
gl_hlift_open/ (Spare)		XP5:1/5	B13	B13	B3	Yes	Yes	Yes	Yes
gl_equalize/ (Spare)		XP5:1/6	B14	B14	B4	Yes	Yes	Yes	Yes
(Spare)		XP5:3/1	B15	B15	B5	Yes	Yes	Yes	Yes
(Spare)		XP5:3/2	B16	B16	B6	Yes	Yes	Yes	Yes
(Spare)		XP5:3/3	B18	B18	B7	Yes	Yes	Yes	Yes
(Spare)		XP5:3/4	B19	B19	B8	Yes	Yes	Yes	Yes
(Spare)		XP5:3/5	B20	B20	B9	Yes	Yes	Yes	Yes
(Spare)		XP5:3/6	B21	B21	B10	Yes	Yes	Yes	Yes
(Spare)		XP5:2/5	C16	C16	B11 ^a	not used	Yes	Yes	Yes
(Spare)		XP5:2/6	C17	C17	B12 ¹	not used	Yes	Yes	Yes
(Spare)		XP5:2/7	C18	C18	B13 ¹	Yes	Yes	Yes	Yes
gl_temp_ok/ (Spare)		XP5:1/7	C19	C19	B14	Yes	Yes	Yes	Yes
(Spare)		XP5:2/8	C20	C20	B15 ¹	Yes	Yes	Yes	Yes
(Spare)		XP5:1/8	C21	C21	C8	Yes	Yes	Yes	Yes

a. Not connected at IRB 6600/6650 ID.

Cbus signals

Name	Sep. screened	Terminal in cabinet	Pin no at base	Pin no at axis 2/3	Pin no at axis 6	Communication types			
						Parallel	Parallel and Can Device Net	Parallel and Interbus	Parallel and Profibus
(Spare) or Bus signal		See comm. types	B22	B22	A1	XP5:2/9	+24 V Can	GNDIM	XP5:2/9
(Spare) or Bus signal		See comm. types	B23	B23	A2	XP5:2/10	0V Can	XP5:2/10	XP5:2/10
(Spare) or Bus signal		See comm. types	B24	B24	A3	XP5:2/11	XP5:2/11	XP5:2/11	XP5:2/11
(Spare) or Bus signal		See comm. types	B25	B25	A4	XP5:2/12	XP5:2/12	XP5:2/12	XP5:2/12
(Spare) or Bus signal	X	See comm. types	A9	A9	A5	not used	XP5:3/9	DO	XP5:3/9
(Spare) or Bus signal	X	See comm. types	A10	A10	A6	not used	XP5:3/10	DO_N	XP5:3/10
(Spare) or Bus signal	X	See comm. types	A3	A3	A7	not used	Can_H	XP5:3/9	XP5:3/7
(Spare) or Bus signal	X	See comm. types	A4	A4	A8	not used	Can_L	XP5:3/10	XP5:3/8
(Spare) or Bus signal	X	See comm. types	A5	A5	A9	not used	XP5:3/7	XP5:3/7	RXD/TXD-P
(Spare) or Bus signal	X	See comm. types	A6	A6	A10	not used	XP5:3/8	XP5:3/8	RXD/TXD-N
(Spare) or Bus signal	x	See comm. types	A11	A11	A11	not used	XP5:3/11	DI	XP5:3/11
(Spare) or Bus signal	X	See comm. types	A12	A12	A12	not used	XP5:3/12	DI_N	XP5:3/12

2 SpotPack and DressPack

2.4.3 Interface description DressPack for Type S

Harting Connector -External routing

The Harting connector for external routing is shown in Figure 81 below. The different main parts within the connector are described in the list below, both with name and Hartings article number. (Corresponding parts at the tool are available with a Connection kit (see chapter 2.10 Connection kits.) and within the Harting product offer).

Name	Harting article no
Hood	09 30 010 0543
Hinged frame, hood	09 14 010 0303
Multicontact, female (HD) (25 pin)	09 14 025 3101
Multicontact, female (EE) (12 pin)	09 14 008 3101
Multicontact, female (DD) (8 pin)	09 14 012 3101

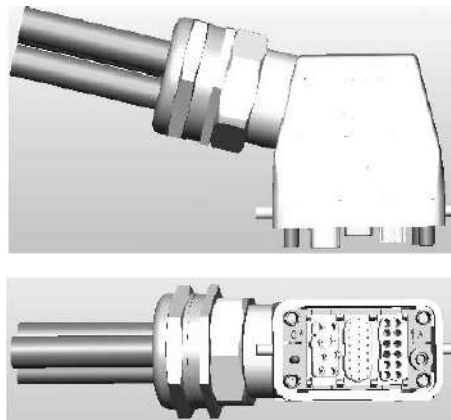

Figure 81 Harting connector for external routing.

Harting connector/hoses Internal routing

Name	Harting article no.
Hood	09 62 040 0301
Multicontact, female (HD) (25 pin)	09 14 025 3101
Multicontact, female (EE) (12 pin)	09 14 008 3101
Multicontact, female (DD) (8 pin)	09 14 012 3101

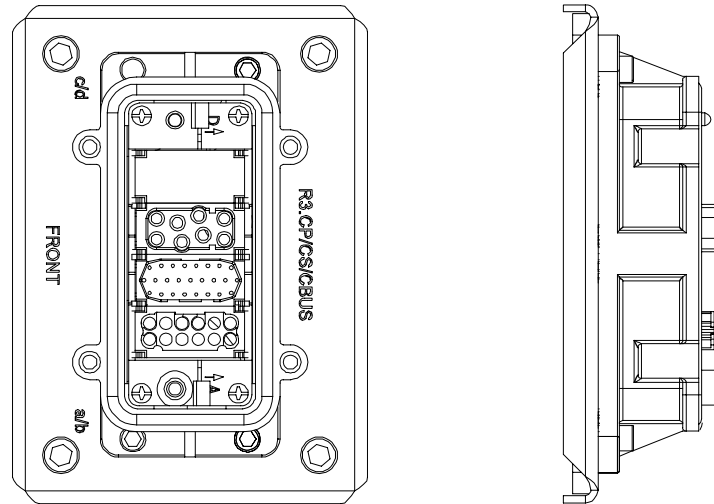

Figure 82 Harting connector for internal routing.

Weld connector and hose fittings, Internal routing

- For the internal routing the weld cable ends with connector type: MC TSB 150/35
- The hoses end with fitting type: Parker Pushlock, (1/2", M22x1,5 Brass, 24 degree seal).

Required general options for Type S

To enable the SpotPack IRB 6600/6650 to perform as intended, general standard robot options are required. These standard options are further described under other chapters but are also mentioned in this chapter.

- Option 716-1 1 pc. Digital 24 VDC I/O 16 inputs/ 16 outputs (Option 717-1 AD Kombi I/O could also be used)
- Option 727-1 24V 8 Amps power supply
- Option 731-1 Safety internal connection
- Option 635-1 Spot. Software option for pneumatic guns (software option 635-2 could also be used)

Required SpotWelding cabinet options for Type S

The SpotPack IRB 6600/6650 also requires a SpotWelding cabinet (option 768-3) to perform as intended. There are five different variants (see below) of SpotWelding cabinet available. Weld timer brand and weld capacity are stated by choosing one of the optional variants. Additional features could then be added to each of the cabinet

2 SpotPack and DressPack

2.4.3 Interface description DressPack for Type S

variant.

All these options are further described under chapter 2.8 SpotWelding cabinet.but are also mentioned in this chapter.

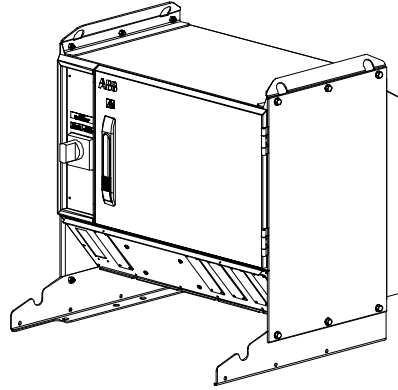

Figure 83 SpotWelding cabinet overview.

Option	Type	Description
782-1	Bosch Basic AC	This option gives a basic SpotWelding cabinet equipped with a weld timer from Bosch with an integrated AC-thyristor with basic capacity. Type Bosch PST 6100.630L1.
782-3	Bosch Extended AC	This option gives an extended SpotWelding cabinet equipped with a weld timer from Bosch with an integrated AC-thyristor with extended capacity. Type Bosch PST 6250.630L1.
782-5	Medar Extended AC	This option gives an extended SpotWelding cabinet equipped with a weld timer from Medar/WTC equipped with an AC-thyristor with extended capacity. Type MEDWELD 4000 single AC.
782-7	Bosch Basic MFDC	This option gives a basic SpotWelding cabinet equipped with a weld timer from Bosch with an integrated inverter with basic capacity. Type Bosch PSI 6100.630L1.
782-9	Medar Basic MFDC	This option gives a basic SpotWelding cabinet equipped with a weld timer from Medar/WTC equipped with an integrated inverter with basic capacity. Type MEDWELD 5000 single MFDC.

Additional options to the different SpotWelding cabinets are mentioned below. For further technical details as well as restrictions in combinations see chapter 2.8 SpotWelding cabinet.

Option	Type	Description
788-1	Forced air cooling	Offers a cooling fan with housing placed on the rear of the SpotWelding cabinet which forces air on the cooling surface/grids of the thyristor or MFDC inverter.
789-1	Earth fault protection unit	Offers a earth fault protection integrated with the circuit breaker for the weld power.
790-1	Contactator for weld power	Offers a weld contactor with necessary wiring placed inside the SpotWelding cabinet.

Option	Type	Description
791-1	Weld power cable, 7 m	Offers floor cable of 7 m length for weld power.
791-2	Weld power cable, 15 m	Offers floor cable of 15 m length for weld power.

Required Water and Air unit options for Type S

The SpotPack IRB 6600/6650 also requires Water and Air unit options to perform as intended. These options are further described under chapter 2.9 Water and Air unit. but are also mentioned in this chapter.

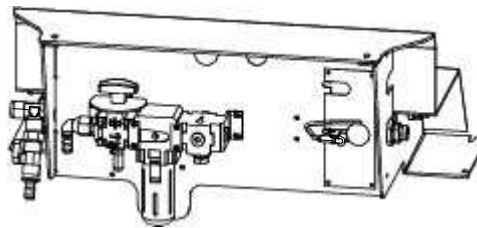

Figure 84 Water and Air unit overview.

Option	Type	Description
792-1	Water and Air unit, type S	Offers the basic water and air unit for type S including splitbox for signal distribution.
793-1	Second water return	Offers an additional water return circuit.
794-1	Digital flow meter, One water return	Offers a digital flow meter instead of a flow switch.
794-2	Digital flow meter, Two water returns	Offers digital flow meter if the option second water return (option 793-1) is chosen.
795-1	Pressure switch and regulator for air	Offers filter regulator and pressure switch for air distribution.
796-1	Electrical proportional valve for air	Offers a proportional valve with cables and additional hoses.
797-1	Cable to split box, 7 m	Offers floor cable of 7 m length for signals between the SpotWelding cabinet and to the split box placed on the water and air unit.
797-2	Cable to split box, 15 m	Offers floor cable of 15 m length for signals between the SpotWelding cabinet and to the split box placed on the water and air unit.
797-3	Cable to split box, 22 m	Offers floor cable of 22 m length for signals between the SpotWelding cabinet and to the split box placed on the water and air unit.
797-1	Cable to split box, 30 m	Offers floor cable of 30 m length for signals between the SpotWelding cabinet and to the split box placed on the water and air unit.

2 SpotPack and DressPack

2.4.4 Summary Type S

2.4.4 Summary Type S

The following options are minimum required to form a complete SpotPack Type S:

DressPack

- Option 16-1 Connection to cabinet, (Cable length and communication type to be stated)
- Option 455-1, 455-4 Parallel or Parallel and Bus communication (Communication type to be stated)
- Option 778-2 SpotWelding
- Option 798-1 or Option 798-2 External routing, DressPack Lower arm (Routing type to be stated)
- Option 780-2 External routing or Option 780-1 Internal routing, DressPack Upper arm (Routing type to be stated)

Another routing alternative without change over connection point is:

- Option 781-1 (and Option 798-2). Routing base to axis 6

General options

- Option 716-1 1 pc. Digital 24 VDC I/O 16 inputs/ 16 outputs
- Option 727-1 24V 8 Amps power supply
- Option 731-1 Safety internal connection
- Option 635-1 Spot

SpotWelding cabinet

- Option 782-1,3,5,7,9 SpotWelding cabinet (weld timer brand and weld capacity to be stated)
- Option 791-1 Power cable 7 m (other length available)

Water and air unit

- Option 792-1 Water and air unit, Type S
- Option 797-1 Splitbox cable 7 m. (other length available)

(Also option 796-1 at the water and air unit is normally required for pneumatic gun handling).

Other described options depends on specific system need and performance.

2.5 Type HS

2.5.1 Introduction

General

Variant Type HS is designed for handling against a stationary mounted SpotWelding pneumatic gun. Included main modules are shown in Figure 85 below. Available configurations with linked option numbers are described below with a start at the DressPack.

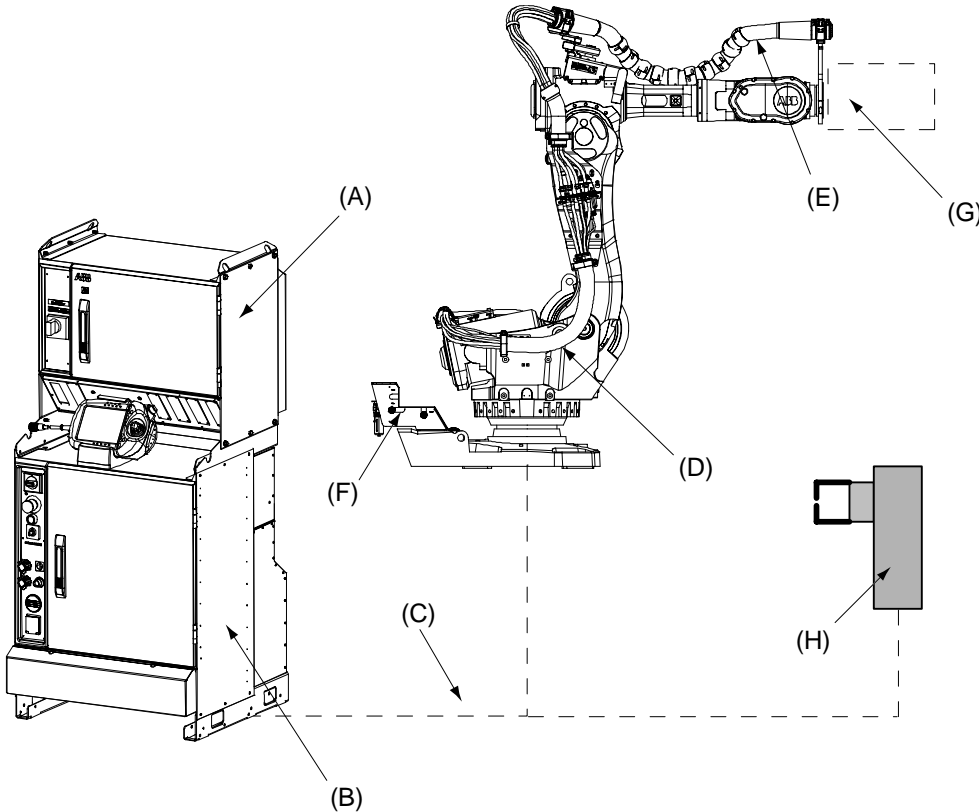

Figure 85 Type HS shown with "Orange line" DressPack.

Pos.	Name
A	SpotWelding cabinet
B	Robot Cabinet IRC5
C	DressPack, Floor
D	DressPack, Lower arm
E	DressPack, Upper arm
F	Water and Air unit with hoses
G	Robot Gripper
H	Stationary gun

2 SpotPack and DressPack

2.5.1 Introduction

Available configurations with linked option numbers are described below.

Option description

Option	Type	Description
16-2	Connection to manipulator	No Floor harness for the DressPack is chosen.
16-1	Connection to cabinet	Floor cables and connections inside the I/O section for the DressPack are chosen. The length and configuration of the floor harness is specified under the options below. Option 94-1,-2,-3,-4 for parallel communication. Option 90-2,-3,-4,-5 for parallel communication and field bus communication with Can/DeviceNet. Option 92-2,-3,-4,-5 for parallel communication and field bus communication with Profibus. Option 91-2,-3,-4,-5 for parallel communication and field bus communication with Interbus.
455-1	Parallel communication	Offers the signal cables needed for parallel communication in lower and upper arm DressPack. To be combined with option 94-1,-2,-3,-4,-5.
455-4	Parallel and Bus communication	Offers the signal cables needed for the combination of parallel and bus communication in lower and upper arm DressPack. To be combined with option 90-2,-3,-4,-5 or 92-2,-3,-4,-5 or 91-2,-3,-4,-5.

- Option 778-1. for the application Material Handling.
- Option 798-1. Internal routing, (Silver line). Offers DressPack Lower arm for Material Handling application with internal routing according to "Silver line".
- Option 798-2. Internal routing, (Orange line). Offers DressPack Lower arm for Material Handling application with internal routing according to "Orange line".
- Option 780-2 and option 798-1. External routing, (Silver line). Offers DressPack upper arm for Material Handling application with external routing according to "Silver line".
- Option 780-2 and option 798-2. External routing, (Orange line). Offers DressPack upper arm for Material Handling application with external routing according to "Orange line".
- Option 780-1 and option 798-2. Internal routing, (Orange line) offers DressPack Upper arm for Material Handling application with internal routing.

The available alternatives and allowed combinations are shown in the schematic Figure 86 below.

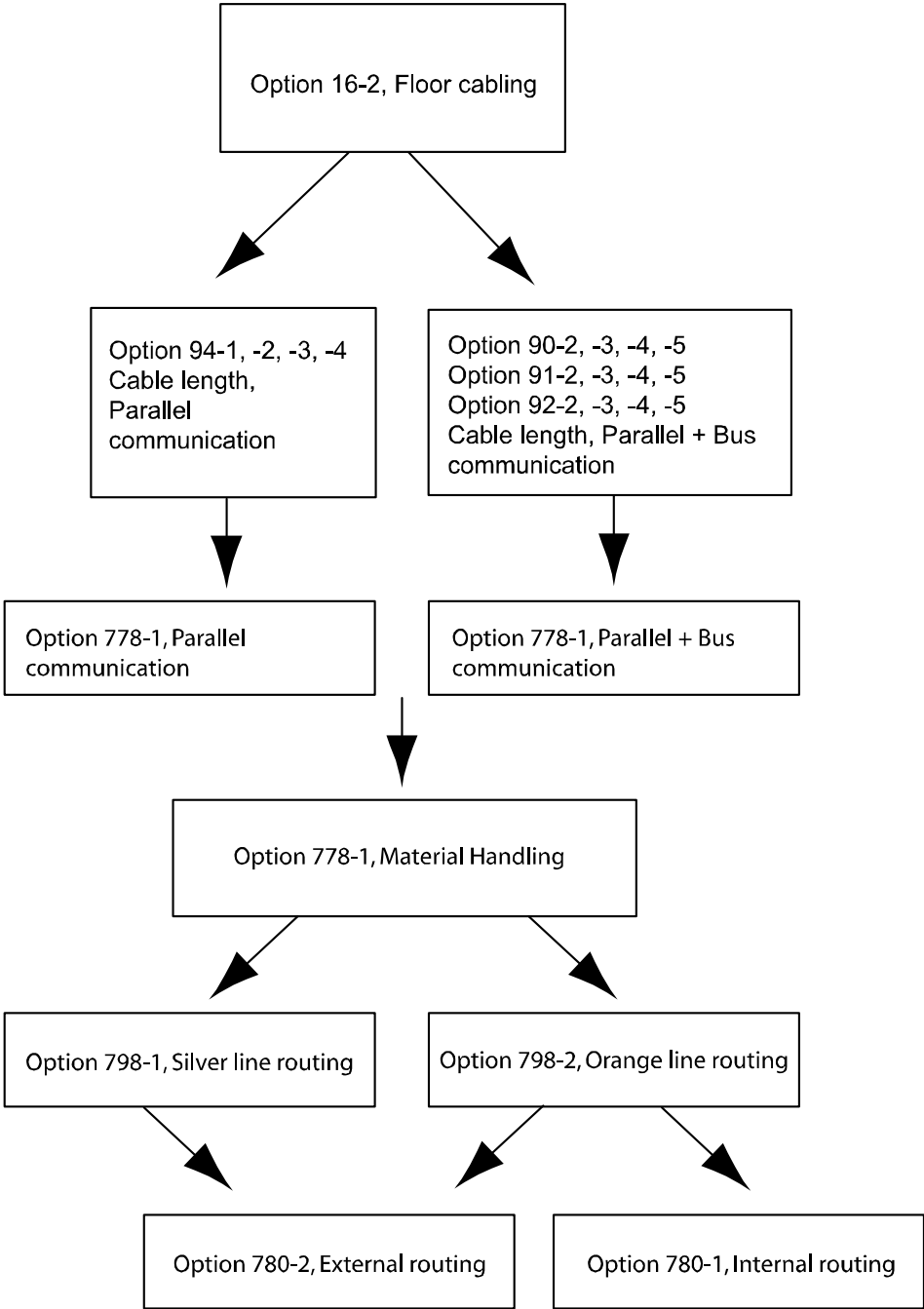

Figure 86 Schematic picture for configuration of DressPack for Material Handling application.

2 SpotPack and DressPack

2.5.2 Configuration result for Type HS

2.5.2 Configuration result for Type HS

General

Depending on the choice of options above the DressPack will have different content. The choice of routing (“Silver line” or “Orange line”) will not affect the content. See tables for signal content below.

DressPack Type HS. Parallel communication

- Option 16-2 or Option 16-1 with Connection to cabinet (option 94-1,-2,-3,-4 to specify cable length)
- Option 455-1 Parallel communication
- Option 778-1 Material Handling
- Option 798-1 or Option 798-2. Internal routing, DressPack Lower arm

One of the options:

- Option 780-2 (and Option 798-1 or Option 798-2). External routing, or
- Option 780-1 (and Option 798-2) Internal routing, DressPack Upper arm

The table below is showing available type of wires/media.

Type	At terminals in cabinet	At Connection point. Base, Axis 2/3 or axis 6	Cable/part area	Allowed capacity
Customer Power (CP)				
Utility Power	2+2	2+2	0,5 mm ²	250 VAC, 5 A rms
Protective earth		1	0,5 mm ²	250 VAC
Customer Signals (CS)				
Signals twisted pair	20	20 (10x2) ^a	0,23 mm ²	50 V DC, 1 A rms
Signals twisted pair and separate shielded	8	8 (4x2)	0,23 mm ²	50 V DC, 1 A rms
Media				
Air (PROC 1)		1	12,5 mm inner diameter	Max. Air pressure 16 bar/230 PSI ^b

a. For IRB 6600/6650 ID 16 signals instead of 20 signals.

b. For IRB 6600/6650 ID Max. air pressure 12 bar.

DressPack Type HS. Parallel and field bus communication, Can/DeviceNet

- Option 16-2 or Option 16-1 with Connection to cabinet (Option 90-2,-3,-4,-5 to specify cable length)
- Option 455-4. Parallel and bus communication
- Option 778-1. Material Handling
- Option 798-1 or Option 798-2. Internal routing, DressPack Lower arm

One of the options:

- Option 780-2 (and Option 798-1 or Option 798-2). External routing, or
- Option 780-1 (and Option 798-2) Internal routing, DressPack Upper arm

The table below is showing available type of wires/media.

Type	At terminals in cabinet	At Connection point. Base, Axis 2/3 or axis 6	Cable/part area	Allowed capacity
Customer Power (CP)				
Utility Power	2+2	2+2	0,5 mm ²	250 VAC, 5 A rms
Protective earth		1	0,5 mm ²	250 VAC
Customer Signals (CS)				
Signals twisted pair	20	20 (10x2) ^a	0,23 mm ²	50 V DC, 1 A rms
Signals twisted pair and separate shielded	8	8 (4x2)	0,23 mm ²	50 V DC, 1 A rms
Customer bus (CBus)				
Bus signals	At bus board	2	0,14 mm ²	Can/DeviceNet spec
Bus signals	At bus board	2	0,23 mm ²	50 V DC, 1 A rms
Signals twisted pair	6	6(3x2)	0,14 mm ²	50 V DC, 1 A rms
Media				
Air (PROC 1)		1	12,5 mm inner diameter	Max. Air pressure 16 bar/230 PSI ^b

a. For IRB 6600/6650 ID 16 signals instead of 20 signals.

b. For IRB 6600/6650 ID Max. air pressure 12 bar.

2 SpotPack and DressPack

2.5.2 Configuration result for Type HS

DressPack Type HS. Parallel and field bus communication, Profibus

- Option 16-2 or Option 16-1 with Connection to cabinet (Option 92-2,-3,-4,-5 to specify cable length)
- Option 455-4 Parallel and bus communication
- Option 778-1 Material Handling
- Option 798-1 or Option 798-2. Internal routing, DressPack Lower arm

One of the options:

- Option 780-2 (and Option 798-1 or Option 798-2). External routing, or
- Option 780-1 (and Option 798-2) Internal routing, DressPack Upper arm

The table below is showing available type of wires/media.

Type	At terminals in cabinet	At Connection point. Base, Axis 2/3 or axis 6	Cable/part area	Allowed capacity
Customer Power (CP)				
Utility Power	2+2	2+2	0,5 mm ²	250 VAC, 5 A rms
Protective earth		1	0,5 mm ²	250 VAC
Customer Signals (CS)				
Signals twisted pair	22	22 (11x2) ^a	0,23 mm ²	50 V DC, 1 A rms
Signals twisted pair and separate shielded	8	8 (4x2)	0,23 mm ²	50 V DC, 1 A rms
Customer bus (CBus)				
Bus signals	At bus board	2	0,14 mm ²	Profibus 12 Mbit/s spec
Signals twisted pair	6	6 (3x2)	0,14 mm ²	50 V DC, 1 A rms
Media				
Air (PROC 1)		1	12,5 mm inner diameter	Max. Air pressure 16 bar/230 PSI ^b

a. For IRB 6600/6650 ID 18 signals instead of 22 signals.

b. For IRB 6600/6650 ID Max. air pressure 12 bar.

DressPack Type HS. Parallel and field bus communication, Interbus

- Option 16-2 or Option 16-1 with Connection to cabinet (Option 91-2,-3,-4,-5 to specify cable length)
- Option 455-4 Parallel and bus communication
- Option 778-1 Material Handling
- Option 798-1 or Option 798-2. Internal routing, DressPack Lower arm

One of the options:

- Option 780-2 (and Option 798-1 or Option 798-2). External routing, or
- Option 780-1 (and Option 798-2) Internal routing, DressPack Upper arm

The table below is showing available type of wires/media.

Type	At terminals in cabinet	At Connection point. Base, Axis 2/3 or axis 6	Cable/part area	Allowed capacity
Customer Power (CP)				
Utility Power	2+2	2+2	0,5 mm ²	250 VAC, 5 A rms
Protective earth		1	0,5 mm ²	250 VAC
Customer Signals (CS)				
Signals twisted pair	21	21 (10x2+1) ^a	0,23 mm ²	50 V DC, 1 A rms
Signals twisted pair and separate shielded	8	8 (4x2)	0,23 mm ²	50 V DC, 1 A rms
Customer bus (CBus)				
Bus signals	At bus board	4	0,14 mm ²	Interbus spec
Bus signals	At bus board	1	0,23 mm ²	50 V DC, 1 A rms
Signals twisted pair	4	4 (2x2)	0,14 mm ²	50 V DC, 1 A rms
Media				
Air (PROC 1)		1	12,5 mm inner diameter	Max. Air pressure 16 bar/230 PSI ^b

a. For IRB 6600/6650 ID 17 signals instead of 21 signals.

b. For IRB 6600/6650 ID Max. air pressure 12 bar.

2 SpotPack and DressPack

2.5.3 Interface description DressPack for Type HS

2.5.3 Interface description DressPack for Type HS

General

The interface at axis 6 has a hose ending with free end for external routing and a fitting for internal routing. The signal cables end with a signal connector type modular Harting. The connector configurations are described in the tables below. Signals with (parentheses) are to be connected by customer inside the robot control cabinet.

Connection

Name	Communication types			
	Parallel	Parallel and Can DeviceNet	Parallel and Interbus	Parallel and Profibus
Harting module type at axis 6	HD+DD+EE	HD+DD+EE	HD+DD+EE	HD+DD+EE

Customer power signals

Name	Sep. screened	Terminal in cabinet	Pin no at base	Pin no at axis 2/3	Pin no at axis 6	Communication types			
						Parallel	Parallel and Can DeviceNet	Parallel and Interbus	Parallel and Profibus
(+24 V)		XP6 / 1	D1	D1	C4	Yes	Yes	Yes	Yes
(0 V)		XP6 / 2	D6	D6	C5	Yes	Yes	Yes	Yes
(+24 V)		XP6 / 3	D3	D3	C6	Yes	Yes	Yes	Yes
(0 V)		XP6 / 4	D4	D4	C7	Yes	Yes	Yes	Yes
PE (in housing)			GND	GND	GND	Yes	Yes	Yes	Yes

Customer signals

Name	Sep. screened	Terminal in cabinet	Pin no at base	Pin no at axis 2/3	Pin no at axis 6	Communication types			
						Parallel	Parallel and Can DeviceNet	Parallel and Interbus	Parallel and Profibus
(Spare)		XP5:1/1	B1	B1	B18	Yes	Yes	Yes	Yes
(Spare)		XP5:1/2	B2	B2	B19	Yes	Yes	Yes	Yes
(Spare)	X	XP5:2/1	B3	B3	B20	Yes	Yes	Yes	Yes
(Spare)	X	XP5:2/2	B4	B4	B21	Yes	Yes	Yes	Yes

Name	Sep. screened	Terminal in cabinet	Pin no at base	Pin no at axis 2/3	Pin no at axis 6	Communication types			
						Parallel	Parallel and Can Device Net	Parallel and Interbus	Parallel and Profibus
(Spare)	X	XP5:2/3	B5	B5	B22	Yes	Yes	Yes	Yes
(Spare)	X	XP5:2/4	B6	B6	B23	Yes	Yes	Yes	Yes
(Spare)	X	XP5:1/9	B7	B7	B24	Yes	Yes	Yes	Yes
(Spare)	X	XP5:1/10	B8	B8	B25	Yes	Yes	Yes	Yes
(Spare)	X	XP5:1/11	B9	B9	B16	Yes	Yes	Yes	Yes
(Spare)	X	XP5:1/12	B10	B10	B17	Yes	Yes	Yes	Yes
(Spare)		XP5:1/3	B11	B11	B1	Yes	Yes	Yes	Yes
(Spare)		XP5:1/4	B12	B12	B2	Yes	Yes	Yes	Yes
(Spare)		XP5:1/5	B13	B13	B3	Yes	Yes	Yes	Yes
(Spare)		XP5:1/6	B14	B14	B4	Yes	Yes	Yes	Yes
(Spare)		XP5:3/1	B15	B15	B5	Yes	Yes	Yes	Yes
(Spare)		XP5:3/2	B16	B16	B6	Yes	Yes	Yes	Yes
(Spare)		XP5:3/3	B18	B18	B7	Yes	Yes	Yes	Yes
(Spare)		XP5:3/4	B19	B19	B8	Yes	Yes	Yes	Yes
(Spare)		XP5:3/5	B20	B20	B9	Yes	Yes	Yes	Yes
(Spare)		XP5:3/6	B21	B21	B10	Yes	Yes	Yes	Yes
(Spare)		XP5:2/5	C16	C16	B11 ^a	not used	Yes	Yes	Yes
(Spare)		XP5:2/6	C17	C17	B12 ^a	not used	Yes	Yes	Yes
(Spare)		XP5:2/7	C18	C18	B13 ^a	Yes	Yes	Yes	Yes
(Spare)		XP5:1/7	C19	C19	B14	Yes	Yes	Yes	Yes
(Spare)		XP5:2/8	C20	C20	B15 ^a	Yes	Yes	Yes	Yes
(Spare)		XP5:1/8	C21	C21	C8	Yes	Yes	Yes	Yes

a. Not connected at IRB 6600/6650 ID.

Cbus signals

Name	Sep. screened	Terminal in cabinet	Pin no at base	Pin no at axis 2/3	Pin no at axis 6	Communication types			
						Parallel	Parallel and Can Device Net	Parallel and Interbus	Parallel and Profibus
(Spare) or Bus signal		See comm. types	B22	B22	A1	XP5:2/9	+24V Can	GNDIM	XP5:2/9
(Spare) or Bus signal		See comm. types	B23	B23	A2	XP5:2/10	0V Can	XP5:2/10	XP5:2/10

2 SpotPack and DressPack

2.5.3 Interface description DressPack for Type HS

Name	Sep. screened	Terminal in cabinet	Pin no at base	Pin no at axis 2/3	Pin no at axis 6	Communication types			
						Parallel	Parallel and Can Device Net	Parallel and Interbus	Parallel and Profibus
(Spare) or Bus signal		See comm. types	B24	B24	A3	XP5:2/11	XP5:2/11	XP5:2/11	XP5:2/11
(Spare) or Bus signal		See comm. types	B25	B25	A4	XP5:2/12	XP5:2/12	XP5:2/12	XP5:2/12
(Spare) or Bus signal		See comm. types	A9	A9	A5	not used	XP5:3/9	DO	XP5:3/9
(Spare) or Bus signal		See comm. types	A10	A10	A6	not used	XP5:3/10	DO_N	XP5:3/10
(Spare) or Bus signal		See comm. types	A3	A3	A7	not used	Can_H	XP5:3/9	XP5:3/7
(Spare) or Bus signal		See comm. types	A4	A4	A8	not used	Can_L	XP5:3/10	XP5:3/8
(Spare) or Bus signal		See comm. types	A5	A5	A9	not used	XP5:3/7	XP5:3/7	RXD/TXD-P
(Spare) or Bus signal		See comm. types	A6	A6	A10	not used	XP5:3/8	XP5:3/8	RXD/TXD-N
(Spare) or Bus signal		See comm. types	A11	A11	A11	not used	XP5:3/11	DI	XP5:3/11
(Spare) or Bus signal		See comm. types	A12	A12	A12	not used	XP5:3/12	DI_N	XP5:3/12

Harting Connector - External routing

The Harting connector for external routing is shown in the Figure 87. The different main parts within the connector are described in the list below, both with name and Harting article number. (Corresponding parts at the tool are available with a Connection kit (see chapter 2.10 Connection kits.) and within the Harting product offer).

Name	Harting article no.
Hood	09 30 010 0543
Hinged frame, hood	09 14 010 0303
Multicontact, female (HD) (25 pin)	09 14 025 3101
Multicontact, female (EE) (12 pin)	09 14 008 3101
Multicontact, female (DD) (8 pin)	09 14 012 3101

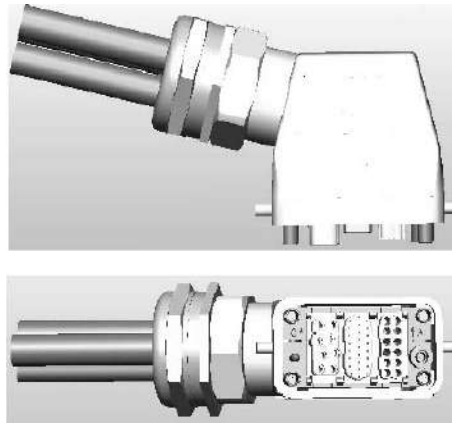

Figure 87 Harting connector external routing.

2 SpotPack and DressPack

2.5.3 Interface description DressPack for Type HS

Harting connector - Internal routing

Name	Harting article no.
Hood	09 62 040 0301
Multicontact, female (HD) (25 pin)	09 14 025 3101
Multicontact, female (EE) (12 pin)	09 14 008 3101
Multicontact, female (DD) (8 pin)	09 14 012 3101

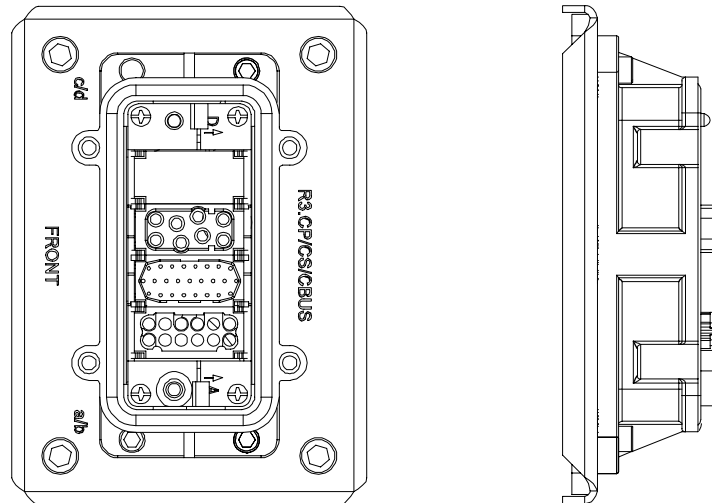

Figure 88 Harting connector for internal routing.

Hose fitting, Internal routing

- For the internal routing the hose ends with fitting type: Parker Pushlock, ($\frac{1}{2}$ " , M22x1,5 Brass, 24 degree seal).

Required general options for Type HS

To enable the SpotPack IRB 6600/6650 to perform as intended, general standard robot options are required. These standard options are further described under other chapters but are also mentioned in this chapter.

- Option 716-1 1 pc. Digital 24 VDC I/O 16 inputs/ 16 outputs (Option 717-1 AD Kombi I/O could also be used)
- Option 727-1 24V 8 Amps power supply
- Option 731-1 Safety internal connection
- Option 635-1 Spot. Software option for pneumatic guns. (software option 635-2 could also be used)

Required SpotWelding cabinet options for Type HS

The SpotPack IRB 6600/6650 also requires a SpotWelding cabinet (option 768-3) to perform as intended. There are five different variants (see below) of SpotWelding cabinet available. Weld timer brand and weld capacity are stated by choosing one of the optional variants. Additional features could then be added to each of the cabinet

variant. All these options are further described under chapter 2.8 SpotWelding cabinet. but are also mentioned in this chapter.

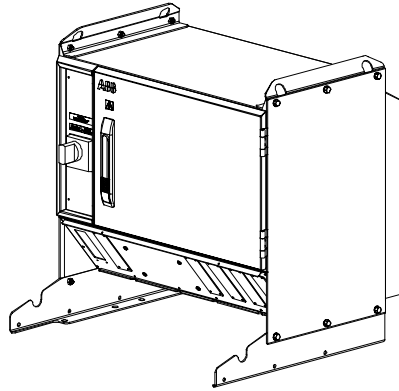

Figure 89 SpotWelding cabinet overview.

Option	Type	Description
782-1	Bosch Basic AC	This option gives a basic SpotWelding cabinet equipped with a weld timer from Bosch with an integrated AC-thyristor with basic capacity. Type Bosch PST 6100.630L1.
782-3	Bosch Extended AC	This option gives an extended SpotWelding cabinet equipped with a weld timer from Bosch with an integrated AC-thyristor with extended capacity. Type Bosch PST 6250.630L1.
782-5	Medar Extended AC	This option gives an extended SpotWelding cabinet equipped with a weld timer from Medar/WTC equipped with an AC-thyristor with extended capacity. Type MEDWELD 4000 single AC.
782-7	Bosch Basic MFDC	This option gives a basic SpotWelding cabinet equipped with a weld timer from Bosch with an integrated inverter with basic capacity. Type Bosch PSI 6100.630L1.
782-9	Option Medar Basic MFDC	This option gives a basic SpotWelding cabinet equipped with a weld timer from Medar/WTC equipped with an integrated inverter with basic capacity. Type MEDWELD 5000 single MFDC.

Additional options to the different SpotWelding cabinets are mentioned below. For further technical details as well as restrictions in combinations see chapter 2.8 SpotWelding cabinet.

Option	Type	Description
788-1	Forced air cooling	Offers a cooling fan with housing placed on the rear of the SpotWelding cabinet which forces air on the cooling surface/grids of the thyristor or MFDC inverter.
789-1	Earth fault protection unit	Offers a earth fault protection integrated with the circuit breaker for the weld power.
790-1	Contactora for weld power	Offers a weld contactor with necessary wiring placed inside the SpotWelding cabinet.
791-1	Weld power cable, 7 m	Offers floor cable of 7 m length for weld power.

2 SpotPack and DressPack

2.5.3 Interface description DressPack for Type HS

Option	Type	Description
791-2	Weld power cable, 15 m	Offers floor cable of 15 m length for weld power.
809-1	Process cable to stationary gun, 7 m	Offers floor cable of 7 m length for process signals between the SpotWelding cabinet and to the stationary gun.
809-2	Process cable to stationary gun, 15 m	Offers floor cable of 15 m length for process signals between the SpotWelding cabinet and to the stationary gun.
809-3	Process cable to stationary gun, 22 m	Offers floor cable of 22 m length for process signals between the SpotWelding cabinet and to the stationary gun.
809-4	Process cable to stationary gun, 30 m	Offers floor cable of 30 m length for process signals between the SpotWelding cabinet and to the stationary gun.

2.5.4 Interface description stationary gun

General

The interface towards the stationary gun includes 3 parts.

- Signal interface with a signal connector type modular Harting (Cable option 809-1,2,3 or 4). The connector configurations are described in the tables below. Signals with (parentheses) are to be connected by customer. Other signals are connected if a complete SpotPack Type HS is ordered.
- Power cable with a Multi Contact interface (Cable option 791-1 or option 791-2) (Ending Multi contact type MC TSB 150/35).
- Water and air connections made by the customer directly on the water and air unit. (See chapter 2.9 Water and Air unit.)

The connector configurations are described in the tables below. Signals with (parentheses) are to be connected by customer in control cabinet end.

Name	Connector Pin SpotWelding cabinet	Connector Pin no. Stationary gun
Harting module type*	(Cable gland)	EE+HD+DD

Customer power signal

Name	Connector Pin SpotWelding cabinet	Connector Pin no. Stationary gun
+24 V	XT 5.6/1	C4
0 V	XT 5.6/2	C5

Customer signals

Name	Connector Pin SpotWelding cabinet	Connector Pin no. Stationary gun
(Spare)	XT 5.6/10	B20
(Spare)	XT 5.6/11	B21
(Spare)	XT 5.6/12	B22
KSR Sep. screened	XT 5.7/1	B24
KSR Sep. screened	XT 5.7/2	B25
(Spare) Sep. screened	XT 5.7/4	B16
(Spare) Sep. screened	XT 5.7/5	B17
gl_close_gun (DO7)	XT 5.6/5	B1
gl_gun_open (DI9)	XT 5.6/6	B2
gl_hlift_open (DI10)	XT 5.6/7	B3
gl_equalize (DO0)	XT 5.6/8	B4
gl_open_hlift (DO8)	XT 5.6/3	B18
gl_close_hlift (DO9)	XT 5.6/4	B19
gl_tempo_ok (DI7)	XT 5.6/9	B14

2 SpotPack and DressPack

2.5.4 Interface description stationary gun

The Harting connector is shown below. The different main parts within the connector are showed both with name and Hartings article number. Corresponding parts at the tool are available within the Harting product offer.

Name	Harting article no.
Hood	09 30 010 0543
Hinged frame, hood	09 14 010 0303
Multicontact, female (HD)	09 14 025 3101
Multicontact, female (EE)	09 14 008 3101
Multicontact, female (DD)	09 14 012 3101

For the contacts above corresponding female crimp-contacts for the different cable diameters are required.

Required Water and Air unit options for Type HS

The SpotPack IRB 6600/6650 also requires Water and Air unit options to perform as intended. These options are further described under chapter 2.9 Water and Air unit.but are also mentioned in this chapter.

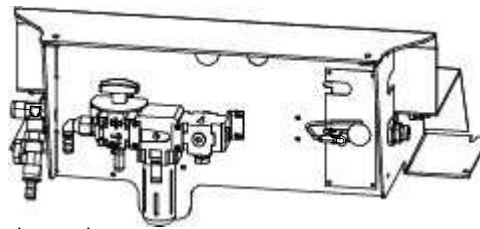

Figure 90 Water and Air unit overview.

Option	Type	Description
792-2	Water and Air unit, type HS	Offers the basic water and air unit for type HS including splitbox for signal distribution.
793-1	Second water return	Offers an additional water return circuit.
794-1	Digital flow meter, One water return	Offers a digital flow meter instead of a flow switch.
794-2	Digital flow meter, Two water returns	Offers digital flow meter if the option second water return (option 793-1) is chosen.
795-1	Pressure switch and regulator for air	Offers filter regulator and pressure switch for air distribution.
796-1	Electrical proportional valve for air	Offers a proportional valve with cables and additional hoses.
797-1	Cable to split box, 7 m	Offers floor cable of 7 m length for signals between the SpotWelding cabinet and to the split box placed on the water and air unit.
797-2	Cable to split box, 15 m	Offers floor cable of 15 m length for signals between the SpotWelding cabinet and to the split box placed on the water and air unit.
797-3	Cable to split box, 22 m	Offers floor cable of 22 m length for signals between the SpotWelding cabinet and to the split box placed on the water and air unit.

Option	Type	Description
797-1	Cable to split box, 30 m	Offers floor cable of 30 m length for signals between the SpotWelding cabinet and to the split box placed on the water and air unit.

2.5.5 Summary Type HS

General

The following options are minimum required to form a complete SpotPack Type HS:

DressPack

- Option 16-1 Connection to cabinet, (Cable length and communication type to be stated)
- Option 455-1, 455-4 Parallel or Parallel and Bus communication (Communication type to be stated)
- Option 778-2 SpotWelding
- Option 798-1 or Option 798-2 External routing, DressPack Lower arm (Routing type to be stated)
- Option 780-2 External routing or Option 780-1 Internal routing, DressPack Upper arm (Routing type to be stated)

Another routing alternative without change over connection point is:

- Option 781-1 (and Option 798-2). Routing base to axis 6

General options

- Option 716-1 1 pc. Digital 24 VDC I/O 16 inputs/ 16 outputs
- Option 727-1 24V 8 Amps power supply
- Option 731-1 Safety internal connection
- Option 635-1 Spot

SpotWelding cabinet

- Option 782-1, 3, 5, 7, 9 SpotWelding cabinet (weld timer brand and weld capacity to be stated)
- Option 791-1 Power cable 7 m (other length available)
- Option 809-1 Process cable to stationary gun

Water and air unit

- Option 792-2 Water and air unit, Type HS
- Option 797-1 Splitbox cable 7 m. (other length available)

(Also option 796-1 at the water and air unit is normally required for pneumatic gun handling).

Other described options depend on specific system need and performance.

2 SpotPack and DressPack

2.6.1 Introduction

2.6 Type Se

2.6.1 Introduction

General

Variant Type Se is designed for SpotWelding application with robot handled servo-controlled tool (electrical gun). Included modules are shown in Figure 91. Available configurations with linked option numbers are described below.

Illustration SpotPack

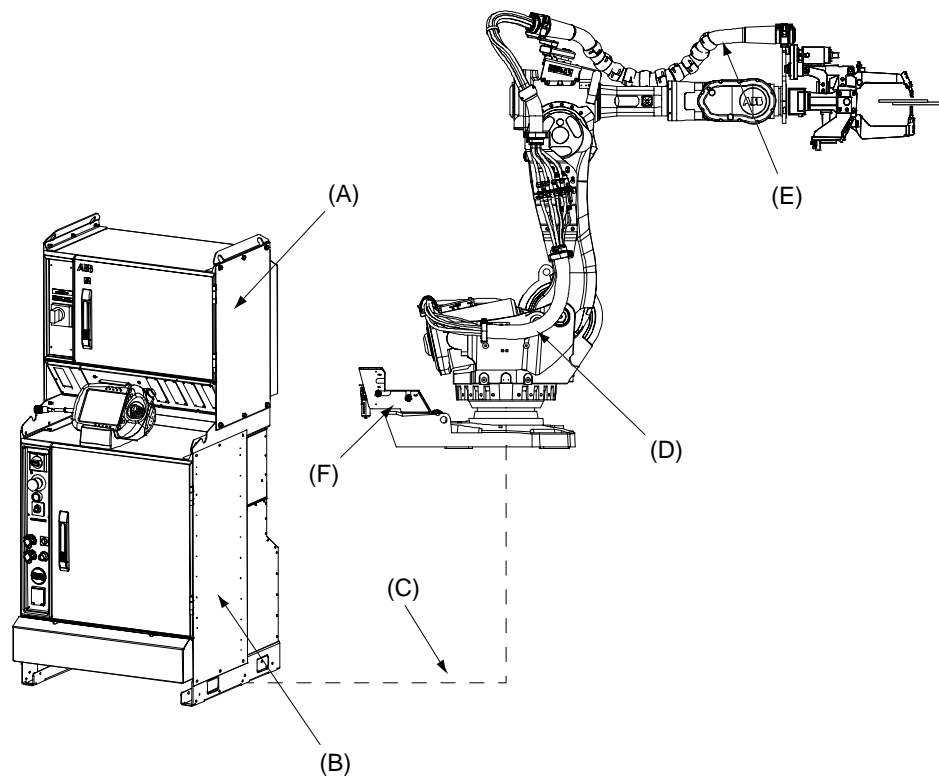

Figure 91 Type Se shown with "Orange line" DressPack.

Pos.	Name
A	SpotWelding cabinet
B	Robot Cabinet IRC5 (including 7th axis drive)
C	DressPack, Floor
D	DressPack, Lower arm
E	DressPack, Upper arm
F	Water and Air unit with hoses

Available configurations with linked option numbers are described below. To achieve the specific servo motor connections within the DressPack option 785-1 Robot gun has also to be chosen. See chapter 1.9.3 Robot Gun.for details.

Option description

Option	Type	Description
16-2	Connection to manipulator	No Floor harness for the DressPack is chosen.
16-1	Connection to cabinet	Floor cables and connections inside the I/O section for the DressPack are chosen. The length and configuration of the floor harness is specified under the options below. Option 94-1,-2,-3,-4 for parallel communication Option 90-2,-3,-4,-5 for parallel communication and field bus communication with Can/DeviceNet Option 92-2,-3,-4,-5 for parallel communication and field bus communication with Profibus Option 91-2,-3,-4,-5 for parallel communication and field bus communication with Interbus
455-1	Parallel communication	Offers the signal cables needed for parallel communication in lower and upper arm DressPack. To be combined with option 94-1,-2,-3,-4.
455-4	Parallel and Bus communication	Offers the signal cables needed for the combination of parallel and bus communication in combination in lower and upper arm DressPack. To be combined with option 90-2,-3,-4,-5 or 92-2,-3,-4,-5 or 91-2,-3,-4,-5.

- Option 778-2 for the application SpotWelding.
- Option 798-1. External routing, (Silver line). Offers DressPack Lower arm for SpotWelding application with external routing according to “Silver line”.
- Option 798-2. External routing, (Orange line). Offers DressPack Lower arm for SpotWelding application with external routing according to “Orange line”.
- Option 780-2 and option 798-1. External routing, (Silver line). Offers DressPack Upper arm for SpotWelding application with external routing according to “Silver line”.
- Option 780-2 and option 798-2. External routing, (Orange line). Offers DressPack Upper arm for SpotWelding application with external routing according to “Orange line”.
- Option 781-1 and option 798-2. Routing base to axis 6. External routing (Orange line). Offers DressPack Lower and Upper arm external routing without intermediate connection point.
- Option 780-1 and option 798-2. Internal routing, (Orange line). Offers DressPack for SpotWelding application with internal routing according to “Orange line”.

The available alternatives and allowed combinations are shown in the schematic Figure 92 below.

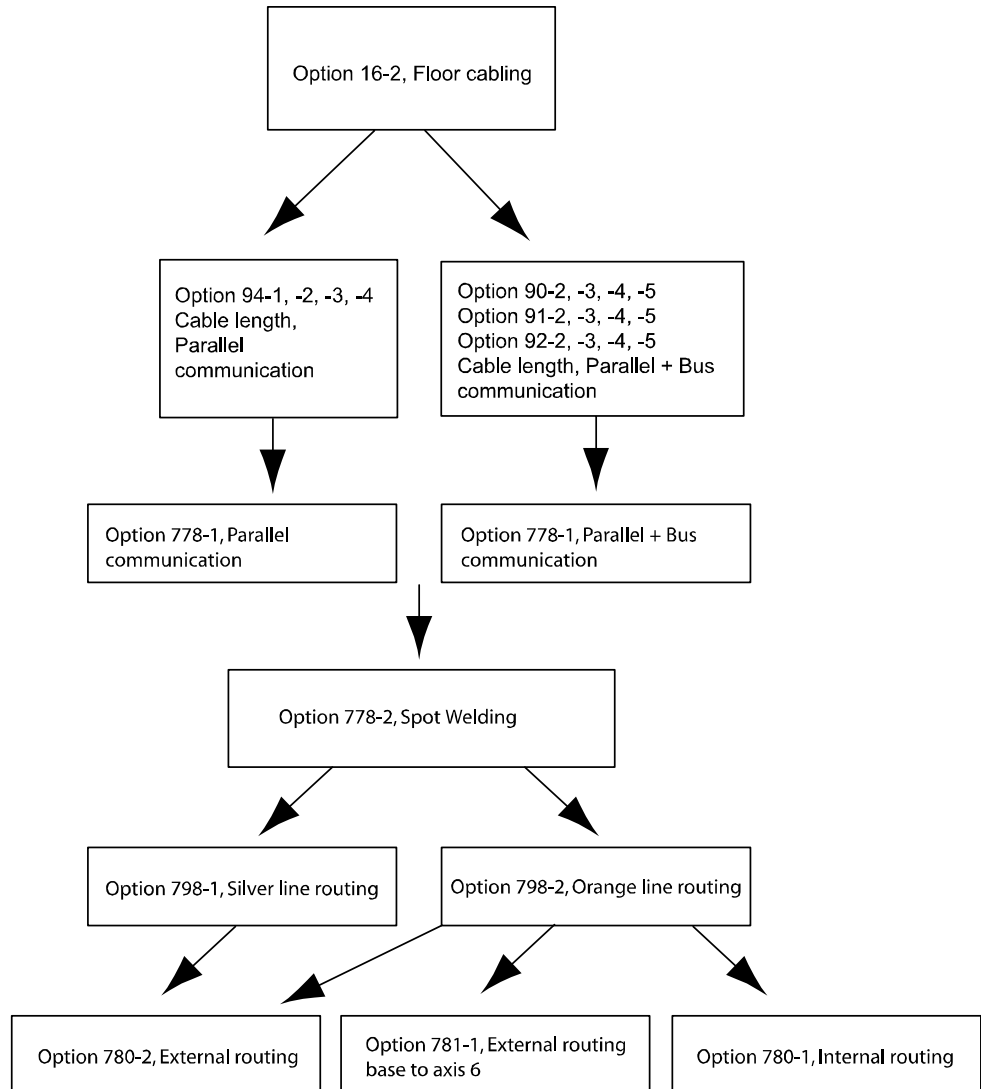

Figure 92 Schematic picture for configuration of DressPack for SpotWelding application.

2.6.2 Configuration result for Type Se

General

Depending on the choice of options above (combined with option 785-1 Robot gun) the DressPack will have different content. The choice of routing (“Silver line” or “Orange line”) will not affect the content. See tables for signal content below.

DressPack Type Se. Parallel communication

- Option 16-2 or 16-1 with Connection to cabinet (option 94-1,-2,-3,-4 to specify cable length)
- Option 455-1 Parallel communication
- Option 778-2 SpotWelding
- Option 798-1 or Option 798-2 External routing, DressPack Lower arm

One of the options

- Option 780-2 (and Option 798-1 or Option 798-2) External routing, DressPack Upper arm, or
- Option 780-1 (and Option 798-2) Internal routing, DressPack Upper arm, or
- Option 781-1 (and Option 798-2). Routing base to axis 6

The table below is showing available type of wires/media.

Type	At terminals in cabinet	At connection point. Base, axis 2/3 or axis 6	Cable/part area	Allowed capacity
Customer Power (CP)				
Utility Power	2+2	2+2	0,5 mm ²	250 VAC, 5 A rms
Protective earth		1	0,5 mm ²	250 VAC
Customer Signals (CS)				
Signals twisted pair	16	16 (8x2)	0,23 mm ²	50 V DC, 1 A rms
Signals twisted pair and separate shielded	4	4 (2x2)	0,23 mm ²	50 V DC, 1 A rms
Servo motor signals				
Servo motor power	At drive	3	1,5 mm ²	600 VAC, 12 A rms
Protective earth	At drive	1	1,5 mm ²	600 VAC
Signals twisted pair for resolver	-	6 ^a	0,23 mm ²	50 V DC, 1 A rms
Brake	-	2	0,23 mm ²	50 V DC, 1 A rms
Temperature control/PTC	-	2	0,23 mm ²	50 V DC, 1 A rms
Media				
Water/Air (PROC 1-4)		4	12,5 mm inner diameter	Max. air pressure 16 bar/ 230 PSI ^b . Max water pressure 10 bar/ 145 PSI
Welding power (WELD)				
Lower and Upper arm		2	35 mm ²	600 VAC, 150 A rms at 20°C (68°F)
Protective earth (Lower and Upper arm)		1	35 mm ²	

a. Interface only at axis 3 or axis 6.

b. For IRB 6600/6650 ID Max. air pressure 12 bar.

2 SpotPack and DressPack

2.6.2 Configuration result for Type Se

DressPack Type Se. Parallel and field bus communication, Can/DeviceNet

- Option 16-2 or Options 16-1 with Connection to cabinet (Option 90-2,-3,-4,-5 to specify cable length)
- Option 455-4 Parallel and bus communication
- Option 778-2 SpotWelding
- Option 798-1 or Option 798-2 External routing, DressPack Lower arm

One of the options:

- Option 780-2 (and Option 798-1 or Option 798-2) External routing, DressPack Upper arm, or
- Option 780-1 (and Option 798-2) Internal routing, DressPack Upper arm, or
- Option 781-1 (and Option 798-2). Routing base to axis 6

The table below is showing available type of wires/media.

Type	At terminals in cabinet	At connection point. Base, axis 2/3 or axis 6	Cable/part area	Allowed capacity
Customer Power (CP) Utility Power Protective earth	2+2	2+2 1	0,5 mm ² 0,5 mm ²	250 VAC, 5 A rms 250 VAC
Customer signals (CS) Signals twisted pair	14	14 (7x2)	0,23 mm ²	50 V DC, 1 A rms
Signals twisted pair and separate shielded	4	4 (1x2)	0,23 mm ²	50 V DC, 1 A rms
Customer bus (CBus) Bus signals	At bus board	2	0,14 mm ²	Can/DeviceNet spec 50 V DC, 1 A rms
Bus signals Signals twisted pair	At bus board 6	2 6 (3x2)	0,23 mm ² 0,14 mm ²	50 V DC, 1 A rms
Servo motor signals Servo motor power Protective earth Signals twisted pair for resolver Brake Temperature control/PTC	At drive At drive - - -	3 1 6 ^a 2 2	1,5 mm ² 1,5 mm ² 0,23 mm ² 0,23 mm ² 0,23 mm ²	600 VAC, 12 A rms 600 VAC 50 V DC, 1 A rms 50 V DC, 1 A rms 50 V DC, 1 A rms
Media Water/Air (PROC 1-4)		4	12,5 mm inner diameter	Max. Air pressure 16 bar/230 PSI ^b . Max. Water pressure 10 bar/145 PSI.
Welding power (WELD) Lower and Upper arm Protective earth (Lower and Upper arm)		2 1	35 mm ² 35 mm ²	600 VAC, 150 A rms at 20°C (68°F)

a. Interface only at axis 3 or axis 6.

b. For IRB 6600/6650 ID Max. air pressure 12 bar.

DressPack Type Se. Parallel and field bus communication, Profibus

- Option 16-2 or Options 16-1 with Connection to cabinet (Option 92-2,-3,-4,-5 to specify cable length)
- Option 455-4 Parallel and bus communication
- Option 778-2 SpotWelding
- Option 798-1 or Option 798-2 External routing, DressPack Lower arm

One of the options:

- Option 780-2 (and Option 798-1 or Option 798-2) External routing, DressPack Upper arm, or
- Option 780-1 (and Option 798-2) Internal routing, DressPack Upper arm, or
- Option 781-1 (and Option 798-2). Routing base to axis 6

The table below is showing available type of wires/media.

Type	At terminals in cabinet	At connection point. Base, axis 2/3 or axis 6	Cable/part area	Allowed capacity
Customer Power (CP)				
Utility Power	2+2	2+2	0,5 mm ²	250 VAC, 5 A rms
Protective earth		1	0,5 mm ²	250 VAC
Customer signals (CS)				
Signals twisted pair	16	16 (8x2)	0,23 mm ²	50 V DC, 1 A rms
Signals twisted pair and separate shielded	4	4 (2x2)	0,23 mm ²	50 V DC, 1 A rms
Customer bus (CBus)				
Bus signals	At bus board	2	0,14 mm ²	Profibus 12 Mbit/s spec
Signals twisted pair	6	6 (3x2)	0,14 mm ²	50 V DC, 1 A rms
Servo motor signals				
Servo motor power	At drive	3	1,5 mm ²	600 VAC, 12 A rms
Protective earth	At drive	1	1,5 mm ²	600 VAC
Signals twisted pair for resolver	-	6 ^a	0,23 mm ²	50 V DC, 1 A rms
Brake	-	2	0,23 mm ²	50 V DC, 1 A rms
Temperature control/PTC	-	2	0,23 mm ²	50 V DC, 1 A rms
Media				
Water/Air (PROC 1-4)		4	12,5 mm inner diameter	Max. Air pressure 16 bar/230 PSI ^b . Max. Water pressure 10 bar/145 PSI.
Welding power (WELD)				
Lower and Upper arm		2	35 mm ²	600 VAC, 150 A rms at 20°C (68°F)
Protective earth (Lower and Upper arm)		1	35 mm ²	

a. Interface only at axis 3 or axis 6.

b. For IRB 6600/6650 ID Max. air pressure 12 bar.

2 SpotPack and DressPack

2.6.2 Configuration result for Type Se

DressPack Type Se. Parallel and field bus communication, Interbus

- Option 16-2 or Options 16-1 with Connection to cabinet (Option 91-2,-3,-4,-5 to specify cable length)
- Option 455-4 Parallel and bus communication
- Option 778-2 SpotWelding
- Option 798-1 or Option 798-2 External routing, DressPack Lower arm

One of the options:

- Option 780-2 (and Option 798-1 or Option 798-2) External routing, DressPack Upper arm, or
- Option 780-1 (and Option 798-2) Internal routing, DressPack Upper arm, or
- Option 781-1 (and Option 798-2). Routing base to axis 6

The table below is showing available type of wires/media.

Type	At terminals in cabinet	At connection point. Base, axis 2/3 or axis 6	Cable/part area	Allowed capacity
Customer Power (CP)				
Utility Power	2+2	2+2	0,5 mm ²	250 VAC, 5 A rms
Protective earth		1	0,5 mm ²	250 VAC
Customer signals(CS)				
Signals twisted pair	15	15 (7x2+1)	0,23 mm ²	50 V DC, 1 A rms
Signals twisted pair and separate shielded	4	4 (2x2)	0,23 mm ²	50 V DC, 1 A rms
Customer bus (CBus)				
Bus signals	At bus board	4	0,14 mm ²	Interbus spec
Bus signals	At bus board	1	0,23 mm ²	50 V DC, 1 A rms
Signals twisted pair	4	4 (2x2)	0,14 mm ²	50 V DC, 1 A rms
Servo motor signals				
Servo motor power	At drive	3	1,5 mm ²	600 VAC, 12 A rms
Protective earth	At drive	1	1,5 mm ²	600 VAC
Signals twisted pair for resolver	-	6 ^a	0,23 mm ²	50 V DC, 1 A rms
Brake	-	2	0,23 mm ²	50 V DC, 1 A rms
Temperature control/PTC	-	2	0,23 mm ²	50 V DC, 1 A rms
Media				
Water/Air (PROC 1-4)		4	12,5 mm inner diameter	Max. Air pressure 16 bar/230 PSI ^b . Max. Water pressure 10 bar/145 PSI.
Welding power (WELD)				
Lower and Upper arm		2	35 mm ²	600 VAC, 150 A rms at 20°C (68°F)
Protective earth (Lower and Upper arm)		1	35 mm ²	

a. Interface only at axis 3 or axis 6.

b. For IRB 6600/6650 ID Max. air pressure 12 bar.

2.6.3 Interface description DressPack for Type Se

Customer Interface

The DressPack interface at axis 6 has a connector type modular Harting for the signals. For external routing the hoses and the weld cable have free ends. For the internal routing the weld cable ends with a connector and the hoses end with fittings. The connector configurations are described in the table below. Signals with (parentheses) are to be connected by customer inside the robot control cabinet.

Name	Communication types			
	Parallel	Parallel and Can DeviceNet	Parallel and Interbus	Parallel and Profibus
Harting module type at axis 6	HD+DD+EE	HD+DD+EE	HD+DD+EE	HD+DD+EE

Customer power signals

Name	Sep. screened	Terminal in cabinet	Pin no at base	Pin no at axis 2/3	Pin no at axis 6	Communication types			
						Parallel	Parallel and Can DeviceNet	Parallel and Interbus	Parallel and Profibus
+24 V		XP6 / 1	D1	D1	C4	Yes	Yes	Yes	Yes
0 V		XP6 / 2	D6	D6	C5	Yes	Yes	Yes	Yes
+24 V		XP6 / 3	D3	D3	C6	Yes	Yes	Yes	Yes
0 V		XP6 / 4	D4	D4	C7	Yes	Yes	Yes	Yes
PE (in housing)			GND	GND	GND	Yes	Yes	Yes	Yes
Servo W (T-fase)		At drive	E	D5	C1	Yes	Yes	Yes	Yes
Servo V (S-fase)		At drive	C	D2	C2	Yes	Yes	Yes	Yes
Servo U (R-fase)		At drive	A	D7	C3	Yes	Yes	Yes	Yes
			G	GND	GND	Yes	Yes	Yes	Yes

2 SpotPack and DressPack

2.6.3 Interface description DressPack for Type Se

Customer signals

Name	Sep. screened	Terminal in cabinet	Pin no at base	Pin no at axis 2/3	Pin no at axis 6	Communication types			
						Parallel	Parallel and Can Device Net	Parallel and Interbus	Parallel and Profibus
X7/(S1)	X			B1	B18	Yes	Yes	Yes	Yes
0V X7/(S3)	X			B2	B19	Yes	Yes	Yes	Yes
Y7/(S4)	X			B3	B20	Yes	Yes	Yes	Yes
0V Y7/(S2)	X			B4	B21	Yes	Yes	Yes	Yes
0V EXC2/(R2)	X			B5	B22	Yes	Yes	Yes	Yes
EXC2/(R1)	X			B6	B23	Yes	Yes	Yes	Yes
KSR	X	XP5:1/9	B7	B7	B24	Yes	Yes	Yes	Yes
KSR	X	XP5:1/10	B8	B8	B25	Yes	Yes	Yes	Yes
(Spare)	X	XP5:1/11	B9	B9	B16	Yes	Yes	Yes	Yes
(Spare)	X	XP5:1/12	B10	B10	B17	Yes	Yes	Yes	Yes
(Spare)		XP5:1/3	B11	B11	B1	Yes	Yes	Yes	Yes
(Spare)		XP5:1/4	B12	B12	B2	Yes	Yes	Yes	Yes
(Spare)		XP5:1/5	B13	B13	B3	Yes	Yes	Yes	Yes
gl_equalize/(Spare)		XP5:1/6	B14	B14	B4	Yes	Yes	Yes	Yes
(Spare)		XP5:3/1	B15	B15	B5	Yes	Yes	Yes	Yes
(Spare)		XP5:3/2	B16	B16	B6	Yes	Yes	Yes	Yes
(Spare)		XP5:3/3	B18	B18	B7	Yes	Yes	Yes	Yes
(Spare)		XP5:3/4	B19	B19	B8	Yes	Yes	Yes	Yes
(Spare)		XP5:3/5	B20	B20	B9	Yes	Yes	Yes	Yes
(Spare)		XP5:3/6	B21	B21	B10	Yes	Yes	Yes	Yes
PTC			J	C1	B11	Yes	Yes	Yes	Yes
0V PTC			K	C2	B12	Yes	Yes	Yes	Yes
24 V Brake release			L	C3	B13	Yes	Yes	Yes	Yes
gl_temp_ok/(Spare)		XP5:1/7	C19	C19	B14	Yes	Yes	Yes	Yes
0 V Brake			M	C5	B15	Yes	Yes	Yes	Yes
(Spare)		XP5:1/8	C21	C21	C8	Yes	Yes	Yes	Yes

Cbus signals

Name	Sep. screened	Terminal in cabinet	Pin no at base	Pin no at axis 2/3	Pin no at axis 6	Communication types			
						Parallel	Parallel and Can Device Net	Parallel and Interbusv	Parallel and Profibusv
(Spare) or Bus signal		See comm. types	B22	B22	A1	XP5:2/9	+24V Can	GNDIM	XP5:2/9
(Spare) or Bus signal		See comm. types	B23	B23	A2	XP5:2/10	0V Can	XP5:2/10	XP5:2/10
(Spare) or Bus signal		See comm. types	B24	B24	A3	XP5:2/11	XP5:2/11	XP5:2/11	XP5:2/11
(Spare) or Bus signal		See comm. types	B25	B25	A4	XP5:2/12	XP5:2/12	XP5:2/12	XP5:2/12
(Spare) or Bus signal	X	See comm. types	A9	A9	A5	not used	XP5:3/9	DO	XP5:3/9
(Spare) or Bus signal	X	See comm. types	A10	A10	A6	not used	XP5:3/10	DO_N	XP5:3/10
(Spare) or Bus signal	X	See comm. types	A3	A3	A7	not used	Can_H	XP5:3/9	XP5:3/7
(Spare) or Bus signal	X	See comm. types	A4	A4	A8	not used	Can_L	XP5:3/10	XP5:3/8
(Spare) or Bus signal	X	See comm. types	A5	A5	A9	not used	XP5:3/7	XP5:3/7	RXD/TXD-P
(Spare) or Bus signal	X	See comm. types	A6	A6	A10	not used	XP5:3/8	XP5:3/8	RXD/TXD-N
(Spare) or Bus signal	x	See comm. types	A11	A11	A11	not used	XP5:3/11	DI	XP5:3/11
(Spare) or Bus signal	X	See comm. types	A12	A12	A12	not used	XP5:3/12	DI_N	XP5:3/12

2 SpotPack and DressPack

2.6.3 Interface description DressPack for Type Se

Harting connection - External routing

The Harting connector for external routing is shown in Figure 93. The different main parts within the connector are described in the list below, both with name and Hartings article number. (Corresponding parts at the tool are available with a Connection kit (see chapter 2.10 Connection kits.) and within the Harting product offer).

Name	Harting article no
Hood	09 30 010 0543
Hinged frame, hood	09 14 010 0303
Multicontact, female (HD) (25 pin)	09 14 025 3101
Multicontact, female (EE) (12 pin)	09 14 008 3101
Multicontact, female (DD) (8 pin)	09 14 012 3101

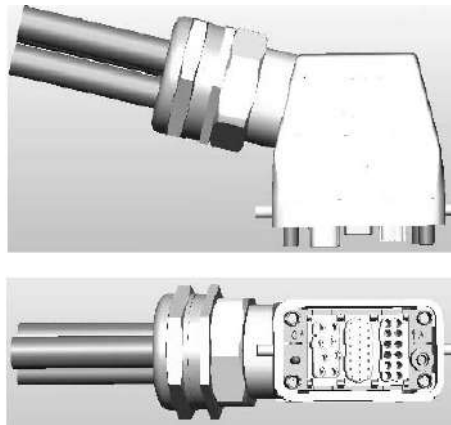

Figure 93 Harting connector for external routing.

Harting connector/hoses Internal routing

Name	Harting article no.
Hood	09 62 040 0301
Multicontact, female (HD) (25 pin)	09 14 025 3101
Multicontact, female (EE) (12 pin)	09 14 008 3101
Multicontact, female (DD) (8 pin)	09 14 012 3101

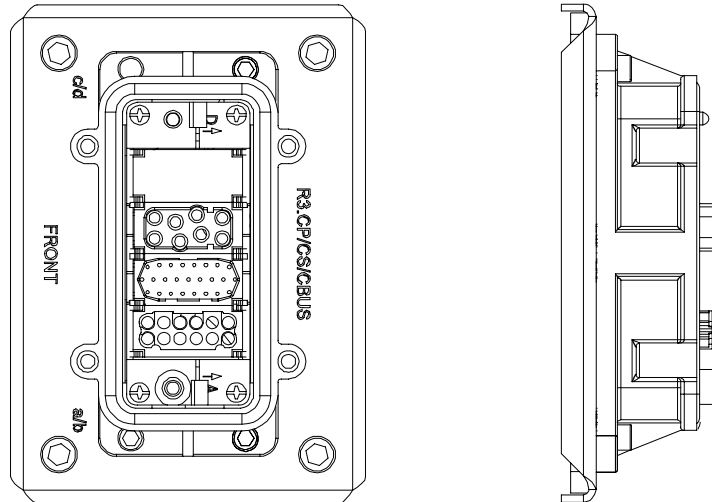

Figure 94 Harting connector for internal routing.

Weld connector and hose fittings, Internal routing

- For the internal routing the weld cable ends with connector type: MC TSB 150/35
- The hoses end with fitting type: Parker Pushlock, (1/2", M22x1,5 Brass, 24 degree seal).

Required general options for Type Se

To enable the SpotPack IRB 6600/6650 to perform as intended, general standard robot options are required. These standard options are further described under other chapters but are also mentioned in this chapter.

- Option 716-1 1 pc. Digital 24 VDC I/O 16 inputs/ 16 outputs (Option 717-1 AD Kombi I/O could also be used)
- Option 727-1 24V 8 Amps power supply
- Option 731-1 Safety internal connection

Required options for servo gun

To enable the spot welding function package SpotPack IRB 6600/6650 to run with a servo controlled gun, some additional (additional to those described in previous section "Required general options for Type Se") servo drive options are required. These

2 SpotPack and DressPack

2.6.3 Interface description DressPack for Type Se

standard options are described under other chapters but are also mentioned below in this chapter.

- Option 770-4 First additional drive, W Drive
- Option 785-1 Robot Gun
- Option 786-1,2,3,4 Connection to first drive (cable length to be stated)
- Option 635-3 Spot Servo. Software option for servo controlled guns. (Software option 635-4 and option 635-5 could also be used)

Also option 630-1, Servo tool change, should be added if servo gun tool change is required.

Required SpotWelding cabinet options for Type Se

The SpotPack IRB 6600/6650 also requires a SpotWelding cabinet (option 768-3) to perform as intended. There are five different variants (see below) of SpotWelding cabinet available. Weld timer brand and weld capacity are stated by choosing one of the optional variants. Additional features could then be added to each of the cabinet variant. All these options are further described under chapter 2.8 SpotWelding cabinet. but are also mentioned in this chapter.

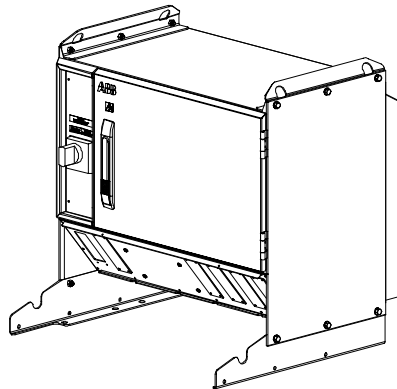

Figure 95 SpotWelding cabinet overview.

Option	Type	Description
782-1	Bosch Basic AC	This option gives a basic SpotWelding cabinet equipped with a weld timer from Bosch with an integrated AC-thyristor with basic capacity. Type Bosch PST 6100.630L1.
782-3	Bosch Extended AC	This option gives an extended SpotWelding cabinet equipped with a weld timer from Bosch with an integrated AC-thyristor with extended capacity. Type Bosch PST 6250.630L1.
782-5	Medar Extended AC	This option gives an extended SpotWelding cabinet equipped with a weld timer from Medar/WTC equipped with an AC-thyristor with extended capacity. Type MEDWELD 4000 single AC.
782-7	Bosch Basic MFDC	This option gives a basic SpotWelding cabinet equipped with a weld timer from Bosch with an integrated inverter with basic capacity. Type Bosch PSI 6100.630L1.

Option	Type	Description
782-9	Medar Basic MFDC	This option gives a basic SpotWelding cabinet equipped with a weld timer from Medar/WTC equipped with an integrated inverter with basic capacity. Type MEDWELD 5000 single MFDC.

Additional options to the different SpotWelding cabinets are mentioned below. For further technical details as well as restrictions in combinations see chapter 2.8 SpotWelding cabinet.

Option	Type	Description
788-1	Forced air cooling	Offers a cooling fan with housing placed on the rear of the SpotWelding cabinet which forces air on the cooling surface/grids of the thyristor or MFDC inverter.
789-1	Earth fault protection unit	Offers a earth fault protection integrated with the circuit breaker for the weld power.
790-1	Contactora for weld power	Offers a weld contactor with necessary wiring placed inside the SpotWelding cabinet.
791-1	Weld power cable, 7 m	Offers floor cable of 7 m length for weld power.
791-2	Weld power cable, 15 m	Offers floor cable of 15 m length for weld power.

Required Water and Air unit options for Type Se

The SpotPack IRB 6600/6650 also requires Water and Air unit options to perform as intended. These options are further described under chapter 2.9 Water and Air unit. but are also mentioned in this chapter.

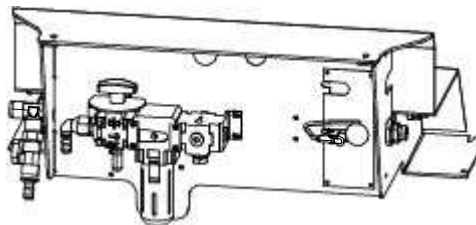

Figure 96 Water and Air unit overview.

Option	Type	Description
792-1	Water and Air unit, type S	Offers the basic water and air unit for type S including splitbox for signal distribution.
793-1	Second water return	Offers an additional water return circuit.
794-1	Digital flow meter, One water return	Offers a digital flow meter instead of a flow switch.
794-2	Digital flow meter, Two water returns	Offers digital flow meter if the option second water return (option 793-1) is chosen.
795-1	Pressure switch and regulator for air	Offers filter regulator and pressure switch for air distribution.
797-2	Cable to split box, 7 m	Offers floor cable of 7 m length for signals between the SpotWelding cabinet and to the split box placed on the water and air unit.

2 SpotPack and DressPack

2.6.3 Interface description DressPack for Type Se

Option	Type	Description
797-2	Cable to split box, 15 m	Offers floor cable of 15 m length for signals between the SpotWelding cabinet and to the split box placed on the water and air unit.
797-3	Cable to split box, 22 m	Offers floor cable of 22 m length for signals between the SpotWelding cabinet and to the split box placed on the water and air unit.
797-1	Cable to split box, 30 m	Offers floor cable of 30 m length for signals between the SpotWelding cabinet and to the split box placed on the water and air unit.

2.6.4 Summary Type Se

DressPack

The following options are minimum required to form a complete SpotPack Type Se:

- Option 16-1 Connection to cabinet, (Cable length and communication type to be stated)
- Option 455-1, 455-4 Parallel or Parallel and Bus communication (Communication type to be stated)
- Option 778-2 SpotWelding
- Option 798-1 or Option 798-2 External routing, DressPack Lower arm (Routing type to be stated)
- Option 780-2 External routing, DressPack Upper arm (Routing type to be stated)

Another routing alternative without change over connection point is:

- Option 781-1 (and Option 798-2). Routing base to axis 6

See Chapter 1.9.3 Robot gun for further drive details.



General options

- Option 716-1 1 pc. Digital 24 VDC I/O 16 inputs/ 16 outputs
- Option 727-1 24V 8 Amps power supply
- Option 731-1 Safety internal connection

Required options for servo gun

- Option 770-4 First additional drive, W Drive
- Option 785-1 Robot Gun
- Option 786-1,2,3,4 Connection to first drive (cable length to be stated)
- Option 635-3 Spot Servo

SpotWelding cabinet

- Option 782-1,3,5,7,9 SpotWelding cabinet (weld timer brand and weld capacity to be stated)
- Option 791-1 Power cable 7 m (other length available)

Water and air unit

- Option 792-1 Water and air unit, Type S
- Option 797-1 Splitbox cable 7 m (other length available)

Other described options depend on specific system need and performance.

2.7 Type HSe

2.7.1 Introduction

General

Variant Type HSe is designed for handling against a stationary mounted Spot Welding servo controlled tool (electrical gun). Included main modules are shown in Figure 97 below. Available configurations with linked option numbers are described below with a start at the DressPack.

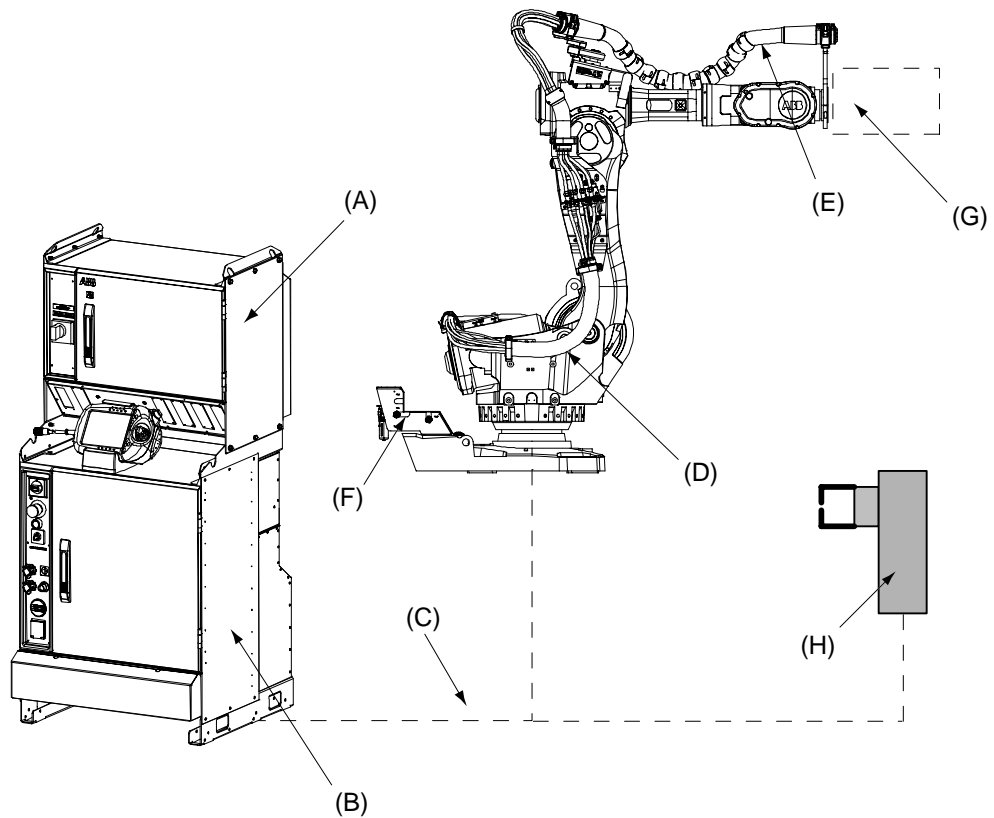

Figure 97 Type HSe shown with "Orange line" DressPack.

Pos.	Name
A	SpotWelding cabinet
B	Robot Cabinet IRC5 (incl. 7 th axis drive)
C	DressPack, Floor
D	DressPack, Lower arm
E	DressPack, Upper arm
F	Water and Air unit with hoses
G	Robot Gripper
H	Stationary gun with axis 7

Available configurations with linked option numbers are described below.

Option description

Option	Type	Description
16-2	Connection to manipulator	No Floor harness for the DressPack is chosen.
16-1	Connection to cabinet	Floor cables and connections inside the I/O section for the DressPack are chosen. The length and configuration of the floor harness is specified under the options below. Option 94-1,-2,-3,-4 for parallel communication. Option 90-2,-3,-4,-5 for parallel communication and field bus communication with Can/DeviceNet. Option 92-2,-3,-4,-5 for parallel communication and field bus communication with Profibus. Option 91-2,-3,-4,-5 for parallel communication and field bus communication with Interbus.
455-1	Parallel communication	Offers the signal cables needed for parallel communication in lower and upper arm DressPack. To be combined with option 94-1,-2,-3,-4,-5.
455-4	Parallel and Bus communication	Offers the signal cables needed for the combination of parallel and bus communication in lower and upper arm DressPack. To be combined with option 90-2,-3,-4,-5 or 92-2,-3,-4,-5 or 91-2,-3,-4,-5.

- Option 778-1. for the application Material Handling.
- Option 798-1. Internal routing, (Silver line). Offers DressPack Lower arm for Material Handling application with internal routing according to “Silver line”.
- Option 798-2. Internal routing, (Orange line). Offers DressPack Lower arm for Material Handling application with internal routing according to “Orange line”.
- Option 780-2 and option 798-1. External routing, (Silver line). Offers DressPack upper arm for Material Handling application with external routing according to “Silver line”.
- Option 780-2 and option 798-2. External routing, (Orange line). Offers DressPack upper arm for Material Handling application with external routing according to “Orange line”.
- Option 780-1 and option 798-2. Internal routing, (Orange line) offers DressPack Upper arm for Material Handling application with internal routing.

The available alternatives and allowed combinations are shown in the schematic Figure 98 below.

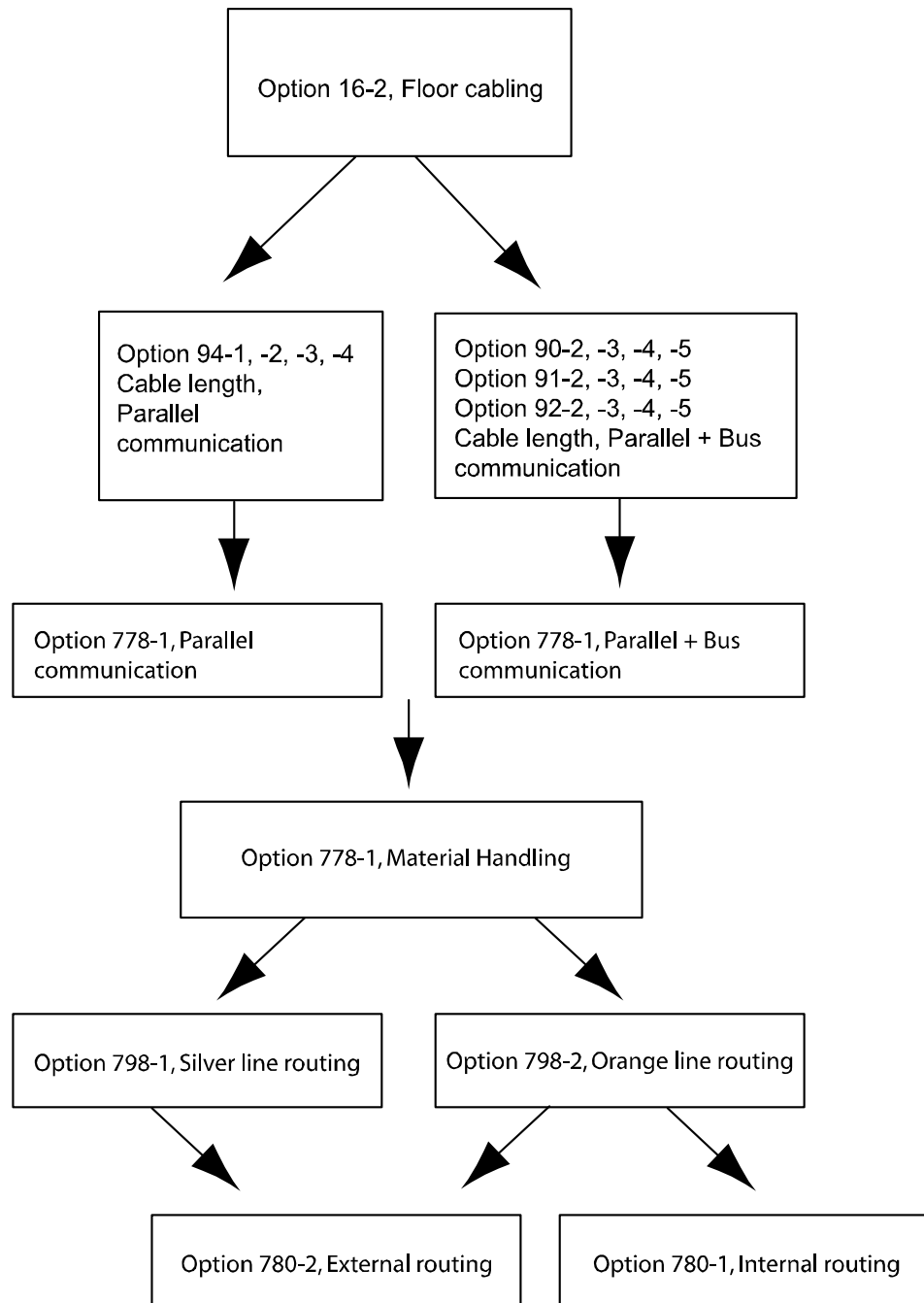

Figure 98 Schematic picture for configuration of DressPack for Material Handling application.

2.7.2 Configuration result for Type HSe

General

Depending on the choice of options above the DressPack will have different content. The choice of routing (“Silver line” or “Orange line”) will not affect the content. See tables for signal content below.

DressPack Type HSe. Parallel communication

- Option 16-2 or Option 16-1 with Connection to cabinet (option 94-1,-2,-3,-4 to specify cable length)
- Option 455-1 Parallel communication
- Option 778-1 Material Handling
- Option 798-1 or Option 798-2. Internal routing, DressPack Lower arm

One of the options:

- Option 780-2 (and Option 798-1 or Option 798-2). External routing, or
- Option 780-1 (and Option 798-2) Internal routing, DressPack Upper arm

The table below is showing available type of wires/media.

Type	At terminals in cabinet	At Connection point. Base, Axis 2/3 or axis 6	Cable/part area	Allowed capacity
Customer Power (CP)				
Utility Power	2+2	2+2	0,5 mm ²	250 VAC, 5 A rms
Protective earth		1	0,5 mm ²	250 VAC
Customer Signals (CS)				
Signals twisted pair	20	20 (10x2) ^a	0,23 mm ²	50 V DC, 1 A rms
Signals twisted pair and separate shielded	8	8 (4x2)	0,23 mm ²	50 V DC, 1 A rms
Media				
Air (PROC 1)		1	12,5 mm inner diameter	Max. Air pressure 16 bar/230 PSI ^b

a. For IRB 6600/6650 ID 16 signals instead of 20 signals.

b. For IRB 6600/6650 ID Max. air pressure 12 bar.

2 SpotPack and DressPack

2.7.2 Configuration result for Type HSe

DressPack Type HSe. Parallel and field bus communication, Can/DeviceNet

- Option 16-2 or Option 16-1 with Connection to cabinet (Option 90-2,-3,-4,-5 to specify cable length)
- Option 455-4 Parallel and bus communication
- Option 778-1 Material Handling
- Option 798-1 or Option 798-2. Internal routing, DressPack Lower arm

One of the options:

- Option 780-2 (and Option 798-1 or Option 798-2). External routing, or
- Option 780-1 (and Option 798-2) Internal routing, DressPack Upper arm

The table below is showing available type of wires/media.

Type	At terminals in cabinet	At Connection point. Base, Axis 2/3 or axis 6	Cable/part area	Allowed capacity
Customer Power (CP)				
Utility Power	2+2	2+2	0,5 mm ²	250 VAC, 5 A rms
Protective earth		1	0,5 mm ²	250 VAC
Customer Signals (CS)				
Signals twisted pair	20	20 (10x2) ^a	0,23 mm ²	50 V DC, 1 A rms
Signals twisted pair and separate shielded	8	8 (4x2)	0,23 mm ²	50 V DC, 1 A rms
Customer bus (CBus)				
Bus signals	At bus board	2	0,14 mm ²	Can/DeviceNet spec
Bus signals	At bus board	2	0,23 mm ²	50 V DC, 1 A rms
Signals twisted pair	6	6(3x2)	0,14 mm ²	50 V DC, 1 A rms
Media				
Air (PROC 1)		1	12,5 mm inner diameter	Max. Air pressure 16 bar/230 PSI ^b

a. For IRB 6600/6650 ID 16 signals instead of 20 signals.

b. For IRB 6600/6650 ID Max. air pressure 12 bar.

DressPack Type HSe. Parallel and field bus communication, Profibus

- Option 16-2 or Option 16-1 with Connection to cabinet (Option 92-2,-3,-4,-5 to specify cable length)
- Option 455-4 Parallel and bus communication
- Option 778-1 Material Handling
- Option 798-1 or Option 798-2. Internal routing, DressPack Lower arm

One of the options:

- Option 780-2 (and Option 798-1 or Option 798-2). External routing, or
- Option 780-1 (and Option 798-2) Internal routing, DressPack Upper arm

The table below is showing available type of wires/media.

Type	At terminals in cabinet	At Connection point. Base, Axis 2/3 or axis 6	Cable/part area	Allowed capacity
Customer Power (CP)				
Utility Power	2+2	2+2	0,5 mm ²	250 VAC, 5 A rms
Protective earth		1	0,5 mm ²	250 VAC
Customer Signals (CS)				
Signals twisted pair	22	22 (11x2) ^a	0,23 mm ²	50 V DC, 1 A rms
Signals twisted pair and separate shielded	8	8 (4x2)	0,23 mm ²	50 V DC, 1 A rms
Customer bus (CBus)				
Bus signals	At bus board	2	0,14 mm ²	Profibus 12 Mbit/s spec
Signals twisted pair	6	6 (3x2)	0,14 mm ²	50 V DC, 1 A rms
Media				
Air (PROC 1)		1	12,5 mm inner diameter	Max. Air pressure 16 bar/230 PSI ^b

a. For IRB 6600/6650 ID 18 signals instead of 22 signals.

b. For IRB 6600/6650 ID Max. air pressure 12 bar.

2 SpotPack and DressPack

2.7.2 Configuration result for Type HSe

DressPack Type HSe. Parallel and field bus communication, Interbus

- Option 16-2 or Option 16-1 with Connection to cabinet (Option 91-2,-3,-4,-5 to specify cable length)
- Option 455-4 Parallel and bus communication
- Option 778-1 Material Handling
- Option 798-1 or Option 798-2. Internal routing, DressPack Lower arm

One of the options:

- Option 780-2 (and Option 798-1 or Option 798-2). External routing, or
- Option 780-1 (and Option 798-2) Internal routing, DressPack Upper arm

The table below is showing available type of wires/media.

Type	At terminals in cabinet	At Connection point. Base, Axis 2/3 or axis 6	Cable/part area	Allowed capacity
Customer Power (CP)				
Utility Power	2+2	2+2	0,5 mm ²	250 VAC, 5 A rms
Protective earth		1	0,5 mm ²	250 VAC
Customer Signals (CS)				
Signals twisted pair	21	21 (10x2+1) ^a	0,23 mm ²	50 V DC, 1 A rms
Signals twisted pair and separate shielded	8	8 (4x2)	0,23 mm ²	50 V DC, 1 A rms
Customer bus (CBus)				
Bus signals	At bus board	4	0,14 mm ²	Interbus spec
Bus signals	At bus board	1	0,23 mm ²	50 V DC, 1 A rms
Signals twisted pair	4	4 (2x2)	0,14 mm ²	50 V DC, 1 A rms
Media				
Air (PROC 1)		1	12,5 mm inner diameter	Max. Air pressure 16 bar/230 PSI ^b

a. For IRB 6600/6650 ID 17 signals instead of 21 signals.

b. For IRB 6600/6650 ID Max. air pressure 12 bar.

2.7.3 Interface description DressPack for Type HSe

General

The interface at axis 6 has a hose ending with free end for external routing and a fitting for internal routing. The signal cables end with a signal connector type modular Harting. The connector configurations are described in the table below. Signals with (parentheses) are to be connected by customer inside the robot control cabinet.

Connection

Name	Communication types			
	Parallel	Parallel and Can DeviceNet	Parallel and Interbus	Parallel and Profibus
Harting module type at axis 6	HD+DD+EE	HD+DD+EE	HD+DD+EE	HD+DD+EE

Customer power signals

Name	Sep. screened	Terminal in cabinet	Pin no at base	Pin no at axis 2/3	Pin no at axis 6	Communication types			
						Parallel	Parallel and Can Device Net	Parallel and Interbus	Parallel and Profibus
(+24 V)		XP6 / 1	D1	D1	C4	Yes	Yes	Yes	Yes
(0 V)		XP6 / 2	D6	D6	C5	Yes	Yes	Yes	Yes
(+24 V)		XP6 / 3	D3	D3	C6	Yes	Yes	Yes	Yes
(0 V)		XP6 / 4	D4	D4	C7	Yes	Yes	Yes	Yes
PE (in housing)			GND	GND	GND	Yes	Yes	Yes	Yes

Customer signals

Name	Sep. screened	Terminal in cabinet	Pin no at base	Pin no at axis 2/3	Pin no at axis 6	Communication types			
						Parallel	Parallel and Can Device Net	Parallel and Interbus	Parallel and Profibus
(Spare)		XP5:1/1	B1	B1	B18	Yes	Yes	Yes	Yes
(Spare)		XP5:1/2	B2	B2	B19	Yes	Yes	Yes	Yes
(Spare)	X	XP5:2/1	B3	B3	B20	Yes	Yes	Yes	Yes
(Spare)	X	XP5:2/2	B4	B4	B21	Yes	Yes	Yes	Yes

2 SpotPack and DressPack

2.7.3 Interface description DressPack for Type HSe

Name	Sep. screened	Terminal in cabinet	Pin no at base	Pin no at axis 2/3	Pin no at axis 6	Communication types			
						Parallel	Parallel and Can Device Net	Parallel and Interbus	Parallel and Profibus
(Spare)	X	XP5:2/3	B5	B5	B22	Yes	Yes	Yes	Yes
(Spare)	X	XP5:2/4	B6	B6	B23	Yes	Yes	Yes	Yes
(Spare)	X	XP5:1/9	B7	B7	B24	Yes	Yes	Yes	Yes
(Spare)	X	XP5:1/10	B8	B8	B25	Yes	Yes	Yes	Yes
(Spare)	X	XP5:1/11	B9	B9	B16	Yes	Yes	Yes	Yes
(Spare)	X	XP5:1/12	B10	B10	B17	Yes	Yes	Yes	Yes
(Spare)		XP5:1/3	B11	B11	B1	Yes	Yes	Yes	Yes
(Spare)		XP5:1/4	B12	B12	B2	Yes	Yes	Yes	Yes
(Spare)		XP5:1/5	B13	B13	B3	Yes	Yes	Yes	Yes
(Spare)		XP5:1/6	B14	B14	B4	Yes	Yes	Yes	Yes
(Spare)		XP5:3/1	B15	B15	B5	Yes	Yes	Yes	Yes
(Spare)		XP5:3/2	B16	B16	B6	Yes	Yes	Yes	Yes
(Spare)		XP5:3/3	B18	B18	B7	Yes	Yes	Yes	Yes
(Spare)		XP5:3/4	B19	B19	B8	Yes	Yes	Yes	Yes
(Spare)		XP5:3/5	B20	B20	B9	Yes	Yes	Yes	Yes
(Spare)		XP5:3/6	B21	B21	B10	Yes	Yes	Yes	Yes
(Spare)		XP5:2/5	C16	C16	B11 ^a	not used	Yes	Yes	Yes
(Spare)		XP5:2/6	C17	C17	B12 ^a	not used	Yes	Yes	Yes
(Spare)		XP5:2/7	C18	C18	B13 ^a	Yes	Yes	Yes	Yes
(Spare)		XP5:1/7	C19	C19	B14	Yes	Yes	Yes	Yes
(Spare)		XP5:2/8	C20	C20	B15 ^a	Yes	Yes	Yes	Yes
(Spare)		XP5:1/8	C21	C21	C8	Yes	Yes	Yes	Yes

a. Not connected at IRB 6600/6650 ID.

Cbus signals

Name	Sep. screened	Terminal in cabinet	Pin no at base	Pin no at axis 2/3	Pin no at axis 6	Communication types			
						Parallel	Parallel and Can Device Net	Parallel and Interbus	Parallel and Profibus
(Spare) or Bus signal		See comm. types	B22	B22	A1	XP5:2/9	+24V Can	GNDIM	XP5:2/9
(Spare) or Bus signal		See comm. types	B23	B23	A2	XP5:2/10	0V Can	XP5:2/10	XP5:2/10

Name	Sep. screened	Terminal in cabinet	Pin no at base	Pin no at axis 2/3	Pin no at axis 6	Communication types			
						Parallel	Parallel and Can Device Net	Parallel and Interbus	Parallel and Profibus
(Spare) or Bus signal		See comm. types	B24	B24	A3	XP5:2/11	XP5:2/11	XP5:2/11	XP5:2/11
(Spare) or Bus signal		See comm. types	B25	B25	A4	XP5:2/12	XP5:2/12	XP5:2/12	XP5:2/12
(Spare) or Bus signal		See comm. types	A9	A9	A5	not used	XP5:3/9	DO	XP5:3/9
(Spare) or Bus signal		See comm. types	A10	A10	A6	not used	XP5:3/10	DO_N	XP5:3/10
(Spare) or Bus signal		See comm. types	A3	A3	A7	not used	Can_H	XP5:3/9	XP5:3/7
(Spare) or Bus signal		See comm. types	A4	A4	A8	not used	Can_L	XP5:3/10	XP5:3/8
(Spare) or Bus signal		See comm. types	A5	A5	A9	not used	XP5:3/7	XP5:3/7	RXD/TXD-P
(Spare) or Bus signal		See comm. types	A6	A6	A10	not used	XP5:3/8	XP5:3/8	RXD/TXD-N
(Spare) or Bus signal		See comm. types	A11	A11	A11	not used	XP5:3/11	DI	XP5:3/11
(Spare) or Bus signal		See comm. types	A12	A12	A12	not used	XP5:3/12	DI_N	XP5:3/12

2 SpotPack and DressPack

2.7.3 Interface description DressPack for Type HSe

Harting Connector - External routing

The Harting connector for external routing is shown in the Figure 99. The different main parts within the connector are described in the list below, both with name and Harting article number. (Corresponding parts at the tool are available with a Connection kit (see chapter 2.10 Connection kits.) and within the Harting product offer).

Name	Harting article no.
Hood	09 30 010 0543
Hinged frame, hood	09 14 010 0303
Multicontact, female (HD) (25 pin)	09 14 025 3101
Multicontact, female (EE) (12 pin)	09 14 008 3101
Multicontact, female (DD) (8 pin)	09 14 012 3101

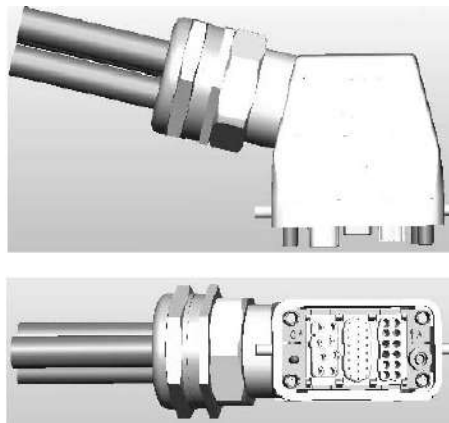

Figure 99 Harting connector external routing.

Harting connector - Internal routing

Name	Harting article no.
Hood	09 62 040 0301
Multicontact, female (HD) (25 pin)	09 14 025 3101
Multicontact, female (EE) (12 pin)	09 14 008 3101
Multicontact, female (DD) (8 pin)	09 14 012 3101

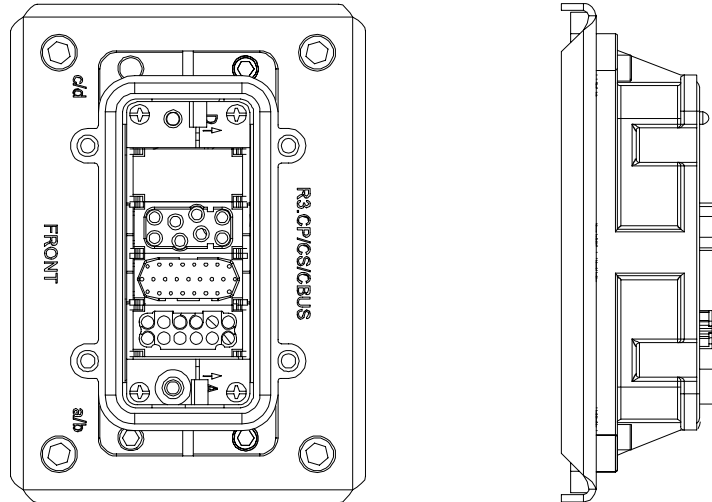

Figure 100 Harting connector for internal routing.

Hose fitting, Internal routing

- For the internal routing the hose ends with fitting type: Parker Pushlock, (½", M22x1,5 Brass, 24 degree seal).

Required general options for Type HSe

To enable the SpotPack IRB 6600/6650 to perform as intended, general standard robot options are required. These standard options are further described under other chapters but are also mentioned in this chapter.

- Option 716-1 1 pc. Digital 24 VDC I/O 16 inputs/ 16 outputs (Option 717-1 AD Kombi I/O could also be used)
- Option 727-1 24V 8 Amps power supply
- Option 731-1 Safety internal connection

2 SpotPack and DressPack

2.7.3 Interface description DressPack for Type HSe

Required options for servo gun

To enable the spot welding function package SpotPack IRB 6600/6650 to run with a servo controlled gun, some additional (additional to those described in previous section "Required general options for Type Se") servo drive options are required. These standard options are described under other chapters but are also mentioned below in this chapter.

- Option 770-4 First additional drive, W Drive
- Option 785-5 Stationary gun
- Option 786-1,2,3,4 Connection to first drive (cable length to be stated)
- Option 635-3 Spot Servo. Software option for servo controlled guns. (Software option 635-4 and option 635-5 could also be used)

Required SpotWelding cabinet options for Type HSe

The SpotPack IRB 6600/6650 also requires a SpotWelding cabinet (option 768-3) to perform as intended. There are five different variants (see below) of SpotWelding cabinet available. Weld timer brand and weld capacity are stated by choosing one of the optional variants. Additional features could then be added to each of the cabinet variant. All these options are further described under chapter 2.8 SpotWelding cabinet. but are also mentioned in this chapter.

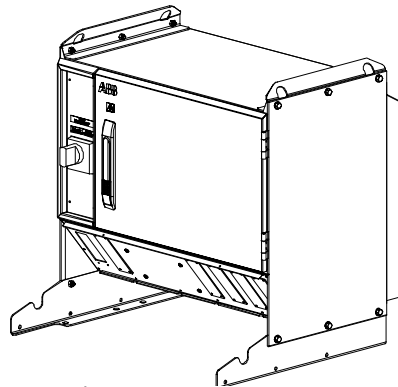

Figure 101 SpotWelding cabinet overview.

Option	Type	Description
782-2	Bosch Basic AC	This option gives a basic SpotWelding cabinet equipped with a weld timer from Bosch with an integrated AC-thyristor with basic capacity. Type Bosch PST 6100.630L1.
782-4	Bosch Extended AC	This option gives an extended SpotWelding cabinet equipped with a weld timer from Bosch with an integrated AC-thyristor with extended capacity. Type Bosch PST 6250.630L1.
782-6	Medar Extended AC	This option gives an extended SpotWelding cabinet equipped with a weld timer from Medar/WTC equipped with an AC-thyristor with extended capacity. Type MEDWELD 4000 single AC.

Option	Type	Description
782-8	Bosch Basic MFDC	This option gives a basic SpotWelding cabinet equipped with a weld timer from Bosch with an integrated inverter with basic capacity. Type Bosch PSI 6100.630L1.
782-10	Medar Basic MFDC	This option gives a basic SpotWelding cabinet equipped with a weld timer from Medar/WTC equipped with an integrated inverter with basic capacity. Type MEDWELD 5000 single MFDC.

Additional options to the different SpotWelding cabinets are mentioned below. For further technical details as well as restrictions in combinations see chapter 2.8 SpotWelding cabinet.

Option	Type	Description
788-1	Forced air cooling	Offers a cooling fan with housing placed on the rear of the SpotWelding cabinet which forces air on the cooling surface/grids of the thyristor or MFDC inverter.
789-1	Earth fault protection unit	Offers a earth fault protection integrated with the circuit breaker for the weld power.
790-1	Contactora for weld power	Offers a weld contactor with necessary wiring placed inside the SpotWelding cabinet.
791-1	Weld power cable, 7 m	Offers floor cable of 7 m length for weld power.
791-2	Weld power cable, 15 m	Offers floor cable of 15 m length for weld power.
809-1	Process cable to stationary gun, 7 m	Offers floor cable of 7 m length for process signals between the SpotWelding cabinet and to the stationary gun.
809-2	Process cable to stationary gun, 15 m	Offers floor cable of 15 m length for process signals between the SpotWelding cabinet and to the stationary gun.
809-3	Process cable to stationary gun, 22 m	Offers floor cable of 22 m length for process signals between the SpotWelding cabinet and to the stationary gun.
809-4	Process cable to stationary gun, 30 m	Offers floor cable of 30 m length for process signals between the SpotWelding cabinet and to the stationary gun.

2 SpotPack and DressPack

2.7.4 Interface description stationary gun

2.7.4 Interface description stationary gun

General

The interface towards the stationary gun includes 5 parts.

- Servo power cable (option 786-1,2,3 or 4). Cable goes from robot control cabinet to stationary gun and ends with a 23 pin Souriau connector (Type UT 061823SH)
- Resolver signal cable, 7 m length (included in option 785-5). Cable goes from robot foot R3.FB7 to stationary gun and ends with a 8 pin Souriau connector (Type UT 06128SH)
- Signal interface with a signal connector type modular Harting (Cable option 809-1,2,3 or 4). The connector configurations are described in the tables below. Signals with (parentheses) are to be connected by customer. Other signals are connected if a complete SpotPack Type HS is ordered
- Power cable with a Multi Contact interface (Cable option 791-1 or option 791-2) (Ending Multi contact Type MC TSB 150/35)
- Water and air connections made by the customer directly on the water and air unit

The connector configurations are described in the tables below. Signals with (parentheses) are to be connected by customer in control cabinet end.

Name	Connector Pin SpotWelding cabinet	Connector Pin no. Stationary gun
Harting module type*	(Cable gland)	EE+HD+DD

Customer power signals

Name	Connector Pin SpotWelding cabinet	Connector Pin no. Stationary gun
+24 V	XT 5.6/1	C4
0 V	XT 5.6/2	C5

Customer signals

Name	Connector Pin SpotWelding cabinet	Connector Pin no. Stationary gun
(Spare)	XT 5.6/10	B20
(Spare)	XT 5.6/11	B21
(Spare)	XT 5.6/12	B22
KSR Sep. screened	XT 5.7/1	B24
KSR Sep. screened	XT 5.7/2	B25
(Spare) Sep. screened	XT 5.7/4	B16
(Spare) Sep. screened	XT 5.7/5	B17
(Spare)	XT 5.6/5	B1
(Spare)	XT 5.6/6	B2
(Spare)	XT 5.6/7	B3
gl_equalize (DO0)	XT 5.6/8	B4
(Spare)	XT 5.6/3	B18

Name	Connector Pin SpotWelding cabinet	Connector Pin no. Stationary gun
(Spare)	XT 5.6/4	B19
temp_ok (DI7)	XT 5.6/9	B14

The Harting connector is shown below. The different main parts within the connector are shown both with name and Hartings article number. Corresponding parts at the tool are available within the Harting product offer.

Name	Harting article no
Hood	09 30 010 0543
Hinged frame, hood	09 14 010 0303
*Multicontact, female (HD)	09 14 025 3101
*Multicontact, female (EE)	09 14 008 3101
*Multicontact, female (DD)	09 14 012 3101

For the contacts above corresponding female crimp-contacts for the different cable diameters are required.

Required Water and Air unit options for Type HSe

The SpotPack IRB 6600/6650 also requires Water and Air unit options to perform as intended. These options are further described under chapters 2.9 Water and Air unit. but are also mentioned in this chapter.

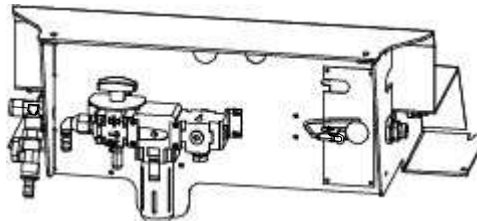

Figure 102 Water and Air unit overview.

Option	Type	Description
792-2	Water and Air unit, type HS	Offers the basic water and air unit for type HS including splitbox for signal distribution.
793-1	Second water return	Offers an additional water return circuit.
794-1	Digital flow meter, One water return	Offers a digital flow meter instead of a flow switch.
794-2	Digital flow meter, Two water returns	Offers digital flow meter if the option second water return (option 793-1) is chosen.
795-1	Pressure switch and regulator for air	Offers filter regulator and pressure switch for air distribution.
796-1	Electrical proportional valve for air	Offers a proportional valve with cables and additional hoses.
797-1	Cable to split box, 7 m	Offers floor cable of 7 m length for signals between the SpotWelding cabinet and to the split box placed on the water and air unit.

2 SpotPack and DressPack

2.7.4 Interface description stationary gun

Option	Type	Description
797-2	Cable to split box, 15 m	Offers floor cable of 15 m length for signals between the SpotWelding cabinet and to the split box placed on the water and air unit.
797-3	Cable to split box, 22 m	Offers floor cable of 22 m length for signals between the SpotWelding cabinet and to the split box placed on the water and air unit.
797-1	Cable to split box, 30 m	Offers floor cable of 30 m length for signals between the SpotWelding cabinet and to the split box placed on the water and air unit.

2.7.5 Summary Type HSe

DressPack

The following options are minimum required to form a complete SpotPack Type HSe:

- Option 16-1 Connection to cabinet, (Cable length and communication type to be stated)
- Option 455-1, 455-4 Parallel or Parallel and Bus communication (Communication type to be stated)
- Option 778-1 Material Handling
- Option 798-1 or Option 798-2 Internal routing, DressPack Lower arm (Routing type to be stated)
- Option 780-2 External routing or option 780-1 Internal routing, DressPack Upper arm (Routing type to be stated)

General options

- Option 716-1 1 pc. Digital 24 VDC I/O 16 inputs/ 16 outputs
- Option 727-1 24V 8 Amps power supply
- Option 731-1 Safety internal connection

Required options for servo gun

- Option 770-4 First additional drive, W Drive
- Option 785-5 Stationary gun
- Option 786-1 Connection to first drive (other length available)
- Option 635-3 Spot Servo. Software option for servo controlled guns

SpotWelding cabinet

- Option 782-2,4,6,8,10 SpotWelding cabinet (weld timer brand and weld capacity to be stated)
- Option 791-1 Power cable 7 m (other length available)
- Option 809-1 Process cable to stationary gun

Water and air unit

- Option 792-2 Water and air unit, Type HS
- Option 797-1 Splitbox cable 7 m. (other length available)

Other described options depend on specific system need and performance.

2.8 SpotWelding cabinet

2.8.1 Introduction

General

The SpotWelding cabinet for SpotPack contains the electric components and circuits needed for spot welding application. The SpotWelding cabinet, with the welding controller built in, is via the process software controlled from the robot controller.

The capacity and functionality depends on the choice of different option combinations.

The SpotWelding cabinet is designed to be placed on top of the robot controller cabinet (Single cabinet version opt 700-3), see Figure 103 below. This is also how it is assembled at delivery.

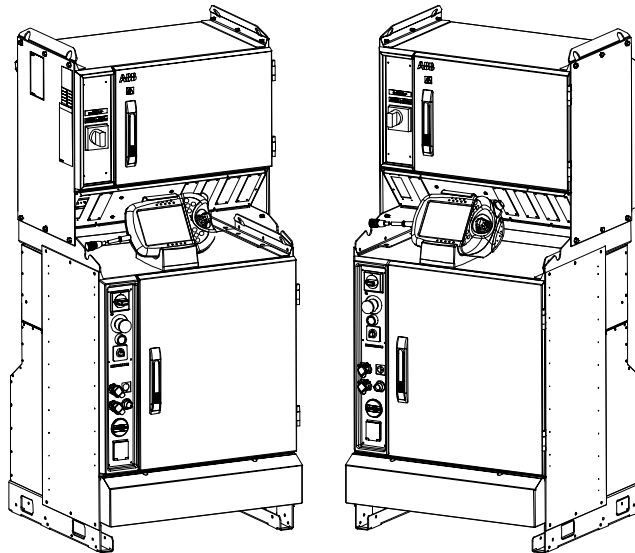

Figure 103 SpotWelding cabinet with robot controller cabinet.

There are interface cables between robot control cabinet and the SpotWelding cabinet (cable length 1,5 m, connected at rear of the control cabinet and at front of SpotWelding cabinet). These cables includes power feeding for control circuits, process signals to the welding gun, safety signals, communication towards weld timer and I/O:s for indication and control. Depending on chosen options wiring will differ (see option descriptions below for further details).

The SpotWelding cabinet has the following common main features.

- Modular built for easy repair and installation (see Figure 104 below)
- Rotary switch with adjustable thermal release (not for UL option) and short circuit release.
- Cross connection of signal handling with separate fusing for different circuits to achieve selectivity.
- Programmable weld timer with proportional valve control.
- A compact cabinet family based on a common platform prepared for additional options and for easy exchange.

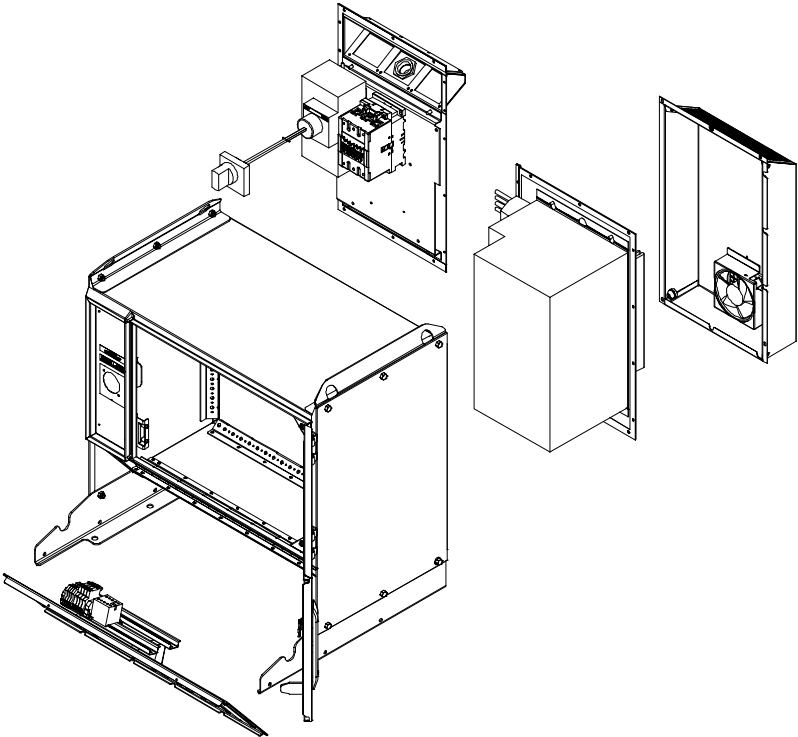

Figure 104 Exploded view drawing of the SpotWelding cabinet.

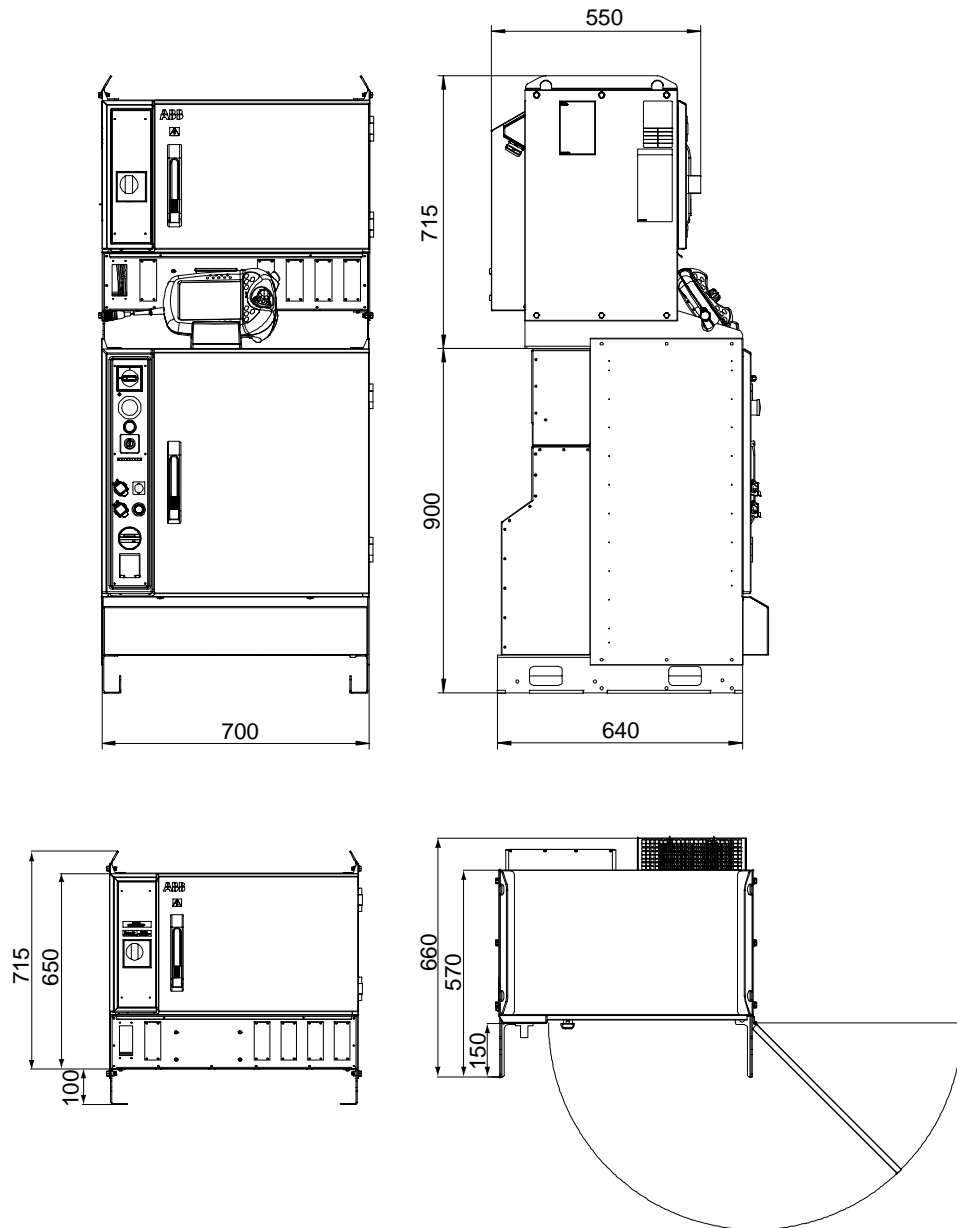

Figure 105 Different views of the SpotWelding cabinet (dimensions in mm).

The electrical circuits of the SpotWelding cabinet consist of weld power circuit and control circuits to control the welding.

Weld power circuit

The welding power for the welding gun is fed through a circuit breaker and welding thyristor (for AC welding) or inverter (for MFDC welding) and further out to the welding power cable. The cabinet is prepared for power feeding from the floor or from top. The welding power cable (outgoing feeding) is connected, via cable gland, directly to terminals inside the SpotWelding cabinet.

The circuit breaker has a built in thermal release that could be adjusted (not for UL version) for customer specific needs to protect welding equipment and to get selec-

tivity in the power circuit. The thermal release is set at 110 A at delivery. The maximum level should not exceed 150 A.

Control Circuits

Power feeding 240/115 V AC and 24 V DC for the control circuits is fed from the robot controller cabinet. Also the safety circuits in the robot controller cabinet are used to interlock the welding timer.

A welding timer (Bosch or WTC/Medar), integrated with the air cooled thyristor or inverter, controls the welding current. The welding timer includes control program that gives possibility to program different weld sequences. The programming is normally done on a programming device or a PC that is connected directly to the welding timer. The interface between the robot system and the welding timer is handled via a field bus interface (Can DeviceNet). Examples of signals are weld start, weld ready, weld program choice and error handling.

Also cross connections, of interface signals and interlocking between the robot system (I/O-boards), the water and air unit, signals to DressPack or stationary gun, are done within the SpotWelding cabinet. The cross connections to the water and air unit are supplied when choosing cable to split box (option 797-1,2,3 or 4). The cross connections for process signals to the stationary gun are supplied when choosing process cable to stationary gun (option 809-1,2,3 or 4).

Programming device for the welding timer is not included in the delivery.

If the option 744-1 is chosen there will follow a door interlock with the SpotWelding cabinet. If option 429-1 is chosen a circuit breaker type T3 will be supplied.

For further information see:

- Installation and Maintenance manual for SpotPack and DressPack
- Circuit diagrams
- Separate manuals for the Bosch or WTC/Medar equipment



The welding capacity as well as the weld timer brand could be chosen among described 5 versions below. Additional features could then be added to each of the cabinet variant.

Option 782-1 Bosch Basic AC

This option gives a basic SpotWelding cabinet equipped with a weld timer from Bosch with an integrated AC-thyristor with basic capacity.

General technical data	Description
Weld timer and thyristor	Bosch PST 6100.630L1
Power feeding	400-600 V AC
Max welding current	130 A rms, 100 kVA transformer
Max wire range, incoming power	3 x 70 mm ²
Main breaker (ABB Sace T1), thermal release	160 A (adjustable) 110-160 A

2 SpotPack and DressPack

2.8.1 Introduction

General technical data	Description
Main breaker, magnetic release	36 kA
Protection class	IP54

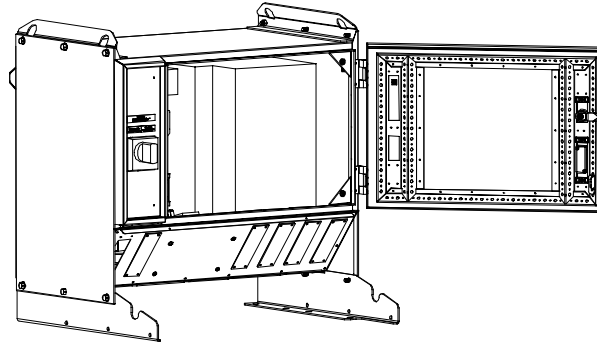

Figure 106 SpotWelding cabinet equipped with a weld timer from Bosch.

Option 782-3 Bosch Extended AC

This option gives an extended SpotWelding cabinet equipped with a weld timer from Bosch with an integrated AC-thyristor with extended capacity.

General technical data	Description
Weld timer and thyristor	Bosch PST 6250.630L1
Max wire range, incoming power	3 x 70 mm ²
Power feeding	400-600 V AC
Max welding current	150 A rms, 250 kVA transformer
Main breaker (ABB Sace T1), thermal release	160 A (adjustable) 110-160 A
Main breaker, magnetic release	36 kA
Protection class	IP54

Option 782-5 Medar Extended AC

This option gives an extended SpotWelding cabinet equipped with a weld timer from WTC/Medar with an integrated AC-thyristor with extended capacity.

General technical data	Description
Weld timer and thyristor	MedWeld 4000 air cooled
Max wire range, incoming power	3 x 70 mm ²
Power feeding	240-575 V AC
Max welding current	150 A rms, 150 kVA transformer
Main breaker (ABB Sace T1), thermal release	160 A (adjustable) 110-160 A
Main breaker, magnetic release	36 kA
Protection class	IP54

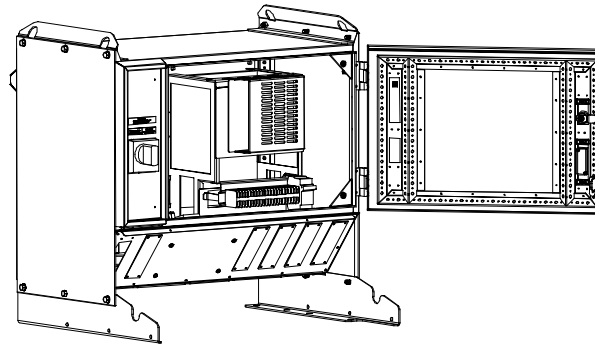

Figure 107 SpotWelding cabinet equipped with a weld timer from WTC/Medar.

Option 782-7 Bosch Basic MFDC

This option gives a basic SpotWelding cabinet equipped with a weld timer from Bosch with an integrated inverter with basic capacity.

General technical data	Description
Weld timer and inverter	Bosch PSI 6100.630L1
Max wire range, incoming power	3 x 70 mm ²
Power feeding	400-480 V AC
Max welding current	110 A rms, 20 kA weld current
Main breaker (ABB Sace T1), thermal release	160 A (adjustable) 110-160 A
Main breaker, magnetic release	36 kA
Protection class	IP54

Option 782-9 Medar Basic MFDC

This option gives a basic SpotWelding cabinet equipped with a weld timer from WTC/Medar equipped with an integrated inverter with basic capacity.

General technical data	Description
Weld timer and inverter	Med Weld 5000
Max wire range, incoming power	3 x 70 mm ²
Power feeding	480 V AC
Max welding current	127 A rms, 40 kA weld current
Main breaker (ABB Sace T1), thermal release	160 A (adjustable) 110-160 A
Main breaker, magnetic release	36 kA
Protection class	IP54

Additional options to the different SpotWelding cabinets are described below.

Option 788-1 Forced air cooling

Offers a cooling fan with housing placed on the rear of the SpotWelding cabinet which forces air on the cooling surface/grids of the thyristor or MFDC inverter (see pictures below). Cabling to the fan goes via a cable gland at the rear of the SpotWelding cabinet. The fan runs continuous when the welding system is powered up.

The fan is required to use together with Bosch MFDC (opt 782-9). For WTC/Medar it's not required as this inverter has a build in fan. For the AC options (opt 782-1,3 and 5) the need will depend on the welding conditions and surrounding temperature.

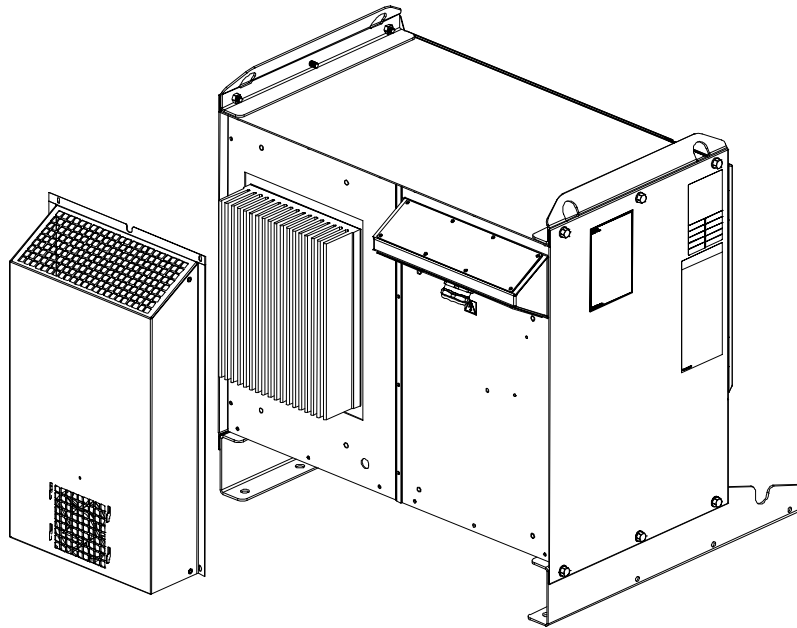

Figure 108 Exploded view drawing showing fan assembly at the rear of the SpotWelding cabinet.

Option 789-1 Earth fault protection unit

Offers a earth fault protection integrated with the circuit breaker for the weld power. This protection could be used for AC welding or MFDC welding. The sensitivity of the earth fault protection could be adjusted. If an earth fault occurs the circuit breaker is tripped.

This option could not be used together with option 768-5,9

Option 790-1 Contactor for weld power

Offers a weld contactor with necessary wiring placed inside the SpotWelding cabinet. The contactor is mounted after the thyristor or inverter and opens up the weld circuit out from the cabinet. It's recommended to be used for increasing safety or when using

tool change for weld guns. The contactor is open when the robot system is in motor off mode or when an specific I/O is set.

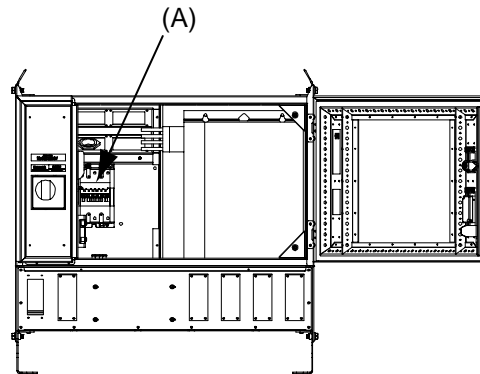

Figure 109 Cabinet with weld contactor, front view.

Pos	Description
A	Weld contactor

Option 791-1 Weld power cable, 7 m

Offers floor cable of 7 m length for weld power (3x35 mm²). One end of the weld power cable is connected at terminals to the weld timer (Bosch or WTC/Medar) or the contactor (when option 790-1 is chosen). The cable enters the SpotWelding cabinet via cable gland. The other end is equipped with an MC connector TSB 150/35 and is connected at either the manipulator base (for robot handled gun Type S or Se) or to the stationary gun (for Type HS or HSe).

Option 791-2 Weld power cable, 15 m

Offers floor cable of 15 m length for weld power (3x35 mm²). See option 791-1 for further details.

Option 809-1 Process cable to stationary gun, 7 m

Offers floor cable of 7 m length for process signals between the SpotWelding cabinet and to the stationary gun. This option also includes internal cross connections between I/O, weld timer and power feeding etc.

One end of the process cable enters the SpotWelding cabinet via cable gland and is connected at Phoenix terminals. The other end is equipped with a HD Harting 3 modules and is connected to the stationary gun (for Type HS or HSe).

Option 809-2, 3 and 4 Process cable to stationary gun

Offers floor cable of 15, 22 or 30 m length for process signals between the SpotWelding cabinet and to the stationary gun. See option 809-1 for further details.

2 SpotPack and DressPack

2.8.2 Interface description SpotWelding cabinet

2.8.2 Interface description SpotWelding cabinet

General

The interface towards the SpotWelding cabinet is described in the tables below.

Connections for SpotWelding cabinet

Type	Pcs	Specification	Allowed capacity
Incoming power from line ^a	1		400-480 VAC, Max. 110 A rms, 50/60 Hz
Outgoing power to robot	1	Cable gland (min 24 mm / max 28 mm cable diameter)	Max. 150 A rms, 50/60 Hz
Floor cable	2	35 mm ²	Max. 600 VAC, 150 A rms at + 20°C (68°F) ambient temperature
Floor cable protective earth	1	35 mm ²	Max. 600 VAC, 150 A rms at + 20°C (68°F) ambient temperature

a. Incoming power connection made by customer. For incoming power and safety recommendations see the Installation and service manual DressPack and SpotPack IRB 6600/6650 3HAC025058-001.

Connections for Signals

Type	Pcs	Specification	Allowed capacity
Water and air unit (XS 103)	1	Modular Harting connector, type DD	24 V DC, Max 0,5 A / output
Stationary gun (XS 104)	1	Modular Harting connector, type HD	24 V DC, Max 0,5 A / output See interface description Stationary gun type HS and HSe

2.9 Water and Air unit

2.9.1 Introduction

General

The Water and Air unit contains components for water and air distribution and control within the SpotPack. The water and air unit is controlled from the robot controller via the process software. Wiring is made via the power unit.

The capacity and functionality depends on the choice of different option combinations, see water and air unit options under this chapter, (end of chapter).

The unit is mounted at the manipulator base. Control cables to the unit have quick connectors in both ends. The unit is only used for the spot welding applications.

The Water and Air unit

The Water and Air unit has the following main features (See Figure 110).

- Adjustable, high speed water flow sensors (switch or digital type)
- Adjustable pressure switch for air
- Possibility to balance water flow for complete package and for individual circuits
- Preparation for additional options and preparation for easy exchange of complete unit or separate circuits
- Equipped with manual cut off valves to make exchange/maintenance easier
- Equipped with measuring points
- Equipped with extra (plugged) air outlets

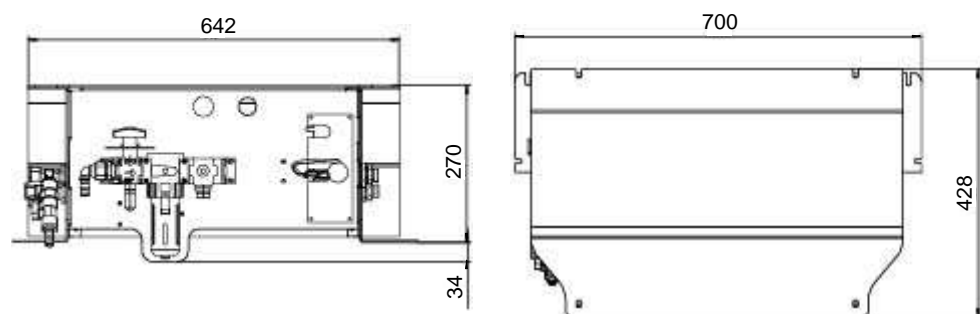

Figure 110 Water and air unit with outer dimensions, media connections, signal connection (dimensions in mm).

The standard water and air unit consists of four main assemblies.

- Water in circuit
- Water return circuit
- Air supply circuit
- Split box

Cables and hoses required for Water and Air unit are defined and described under each option for water and air unit.

2 SpotPack and DressPack

2.9.1 Introduction

Water in circuit

The function of the water in circuit is to open / close the cooling water supply to the Spot welding gun (See Figure 111). An electrically controlled valve with indication LED is used. The valve is controlled by a digital signal from the robot control system. The circuit begins from left with a Parker Pushlock 33482-8-8BK fitting for ½” hose (hose assembled by customer), manual shut off valve for the cooling water flow, electrical shut off valve and ends with a Parker Pushlock adapter. (Suitable for a Parker Pushlock DIN 20 078 A, we recommend a Parker Pushlock 39C82-15-8BK fitting). From this point the water is led to the gun/robot base.

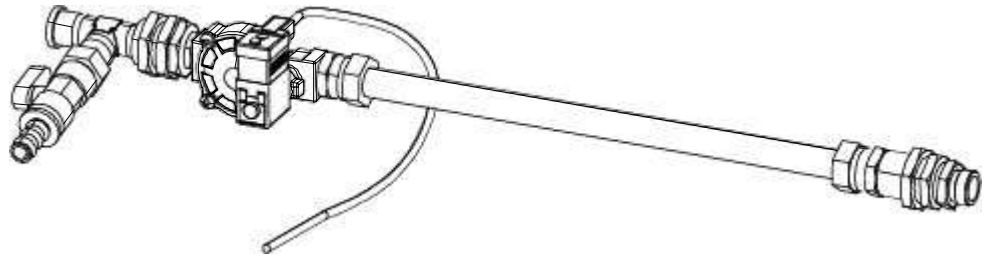

Figure 111 Water in circuit.

Water return circuit

The water return circuit monitors the flow of the returning cooling water from the Spot welding gun (See Figure 112). The flow switch detects if the water flow is too low in the cooling water circuit.

The flow switch gives a digital signal to the robot control system, which automatically shuts off the electrical shut off valve in the water in circuit if the flow is too low. The system and the supply of cooling water are then automatically stopped to minimize risk of damage to the system.

The water return circuit is delivered with a pre-set flow limit, set to approx. 3,5 liters per minute.

The water return circuit begins from right with a Parker Pushlock adapter (suitable for a Parker Pushlock DIN 20 078 A, we recommend a Parker Pushlock 39C82-15-8BK fitting), flow switch with a switching point between 2-12 liters per minute.

It's also equipped with a flow control valve; the flow control can adjust the water flow to a wanted flow level. The flow-value can be monitored through a small window on the flow control valve. This will serve as a rough function check in the approximate flow range of 2-8 liters per minute. The circuit ends with a check-valve that will stop any reversing water flow, manual shut off valve and a Parker Pushlock 33482-8-8BK fitting for ½” hose (hose assembled by customer). From this point the water is led to the factory water system.

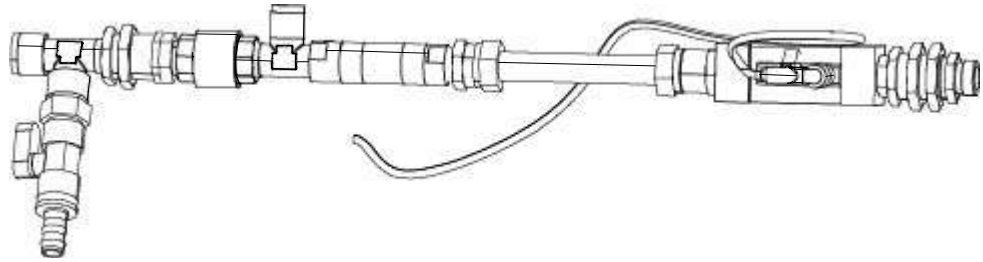

Figure 112 Water return circuit.

Air supply circuit

The air supply circuit provides the function package with filtered air. (See Figure 113).

The air supply circuit begins with a Parker Pushlock 39C82-15-8BK fitting (hose assembled by customer). Manually operated shut off valve to vent the system through a silencer, air filter 25 microns and a water separator equipped with a metal bowl protection, distribution block containing plugged air outlet ports.

The air supply circuit ends with a Parker Pushlock adapter. (Suitable for a Parker Pushlock DIN 20 078 A, we recommend a Parker Pushlock 39C82-15-8BK fitting).

Maximum flow capacity is 3000 litres per minute at 6.3 bar and $\Delta P = 1.0$ bar. Maximum allowed pressure is 16 bar.

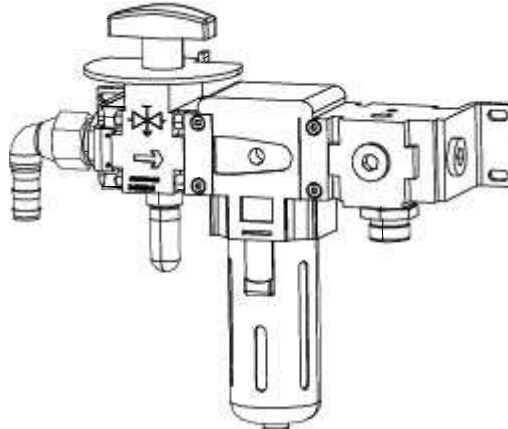

Figure 113 Air Supply Circuit.

Split box

With the split box, the 24VDC supply and signals are connected and distributed to the different units on the water and air unit, see picture below. The design makes disconnection of separate items for service and repair on the water and air unit very easy. The split box has a protection class IP68, which means it is well protected against dust and water leakage.

2 SpotPack and DressPack

2.9.1 Introduction

Signals for water and air unit

Electrical connections to robot I/O board are made via the splitbox on the water and air unit.

Total 6 x M12 connections (4 pins) are available. The number in use depends on option choices but minimum 2 are in use within the SpotPack. Free connections can be used for customer purpose like tip-dresser control.

The split box has six connections prepared for the following units.

- 1. Electric water shut off valve
- 2. Flow switch 1
- 3. Flow switch 2 (Option 793-1 Second Water Return)
- 4. Pressure switch (Option 795-1 Pressure switch and Regulator for air)
- 5. Proportional valve (Option 796-1 Electrical proportional valve for air)
- 6. Spare

The cable and cable length between the Split box and the SpotWelding cabinet must be specified (see option 797-1,2,3,4).

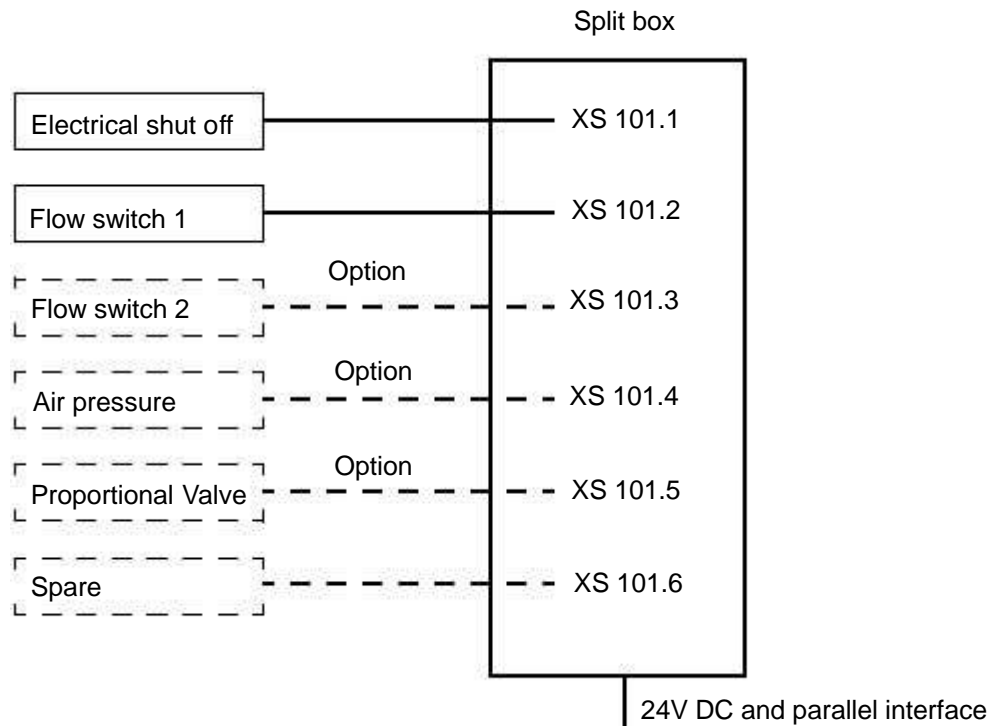

Figure 114 Block diagram.

Option	Type	Description
792-1	Water and Air unit, type S	The basic water and air unit for type S (See Figure 40) is equipped for a robot handled gun and with the following components: Water in circuit Water return circuit Air supply circuit Split box 1/2 " hose between air supply circuit and manipulator base (PROC 1) 1/2 " hose between water in circuit and manipulator base (PROC 2) 1/2 " hose between water return circuit and manipulator base (PROC 3)

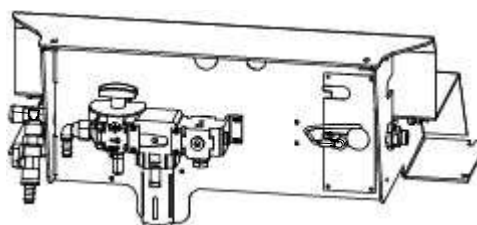

Figure 115 Water and air unit basic.

Option	Type	Description
792-2	Water and Air unit, type HS	The basic water and air unit for type HS is equipped for a pedestal/stationary gun and with the following components: Water in circuit Water return circuit Air supply circuit Split box 1/2 " hose between air supply circuit and manipulator base (PROC 1) Hoses between water in circuit and water return circuit are not supplied. These have to be arranged by the customer.
793-1	Second water return	Offers an additional water return circuit (See Figure 116). The option contains an extra flow switch to monitor the water coming from the second circuit and a flow control valve. For more information see under Flow switch in water return circuit.



Please note that for type S and Se there are some restrictions. Option 793-1 can not be combined with option 796-1. Additional 1/2" water hose (PROC 4) from Water and Air unit to manipulator base is included.

2 SpotPack and DressPack

2.9.1 Introduction

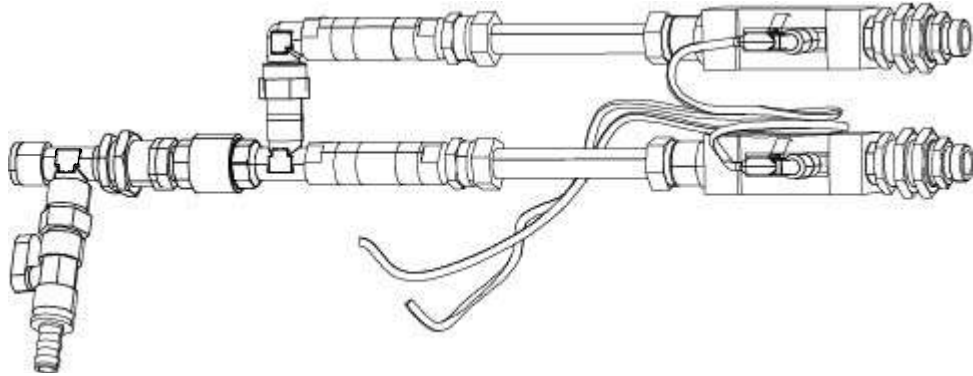

Figure 116 Second Water Return.

Option	Type	Description
794-1	Digital flow meter, One water return	<p>Offers a digital flow meter instead of a flow switch (See Figure 117). This option is valid for one water return (if second water return see option 793-1). This option means that the flow switch and the flow control valve with visible flow indication is replaced by the digital flow meter and a flow control valve without visible flow indication (not required as adjustments can be seen on the digital flow meter).</p> <p>The digital flow meter gives the following advantages compared to flow switch</p> <ul style="list-style-type: none"> The biggest advantage is that the flow switch is mechanical function safe, which means that if something damages the flow switch you will notice that immediately The actual flow could be seen direct on the display The flow switch level and the tolerance could be set with high tolerance The flow value can be monitored at distance with a remote display.

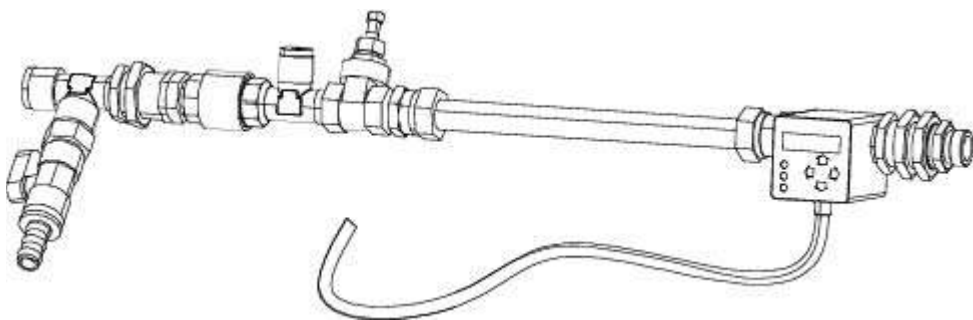

Figure 117 Digital flow meter.

Option	Type	Description
794-2	Digital flow meter, Two water returns	Offers digital flow meter if the option second water return (option 793-1) is chosen. For more information see option 794-1.

Option	Type	Description
795-1	Pressure switch and regulator for air	Offers, filter regulator, pressure switch and a manually operated pressure regulator to set the incoming pressure to the Spot welding gun. The pressure can be monitored on the included pressure gauge. This option also includes a Pressure Switch to monitor the air pressure and to give a signal to the control system if the pressure becomes to low.
796-1	Electrical proportional valve for air	Offers a proportional valve with integrated control circuit and connection cable to the splitbox (See Figure 118). The proportional valve controls the welding force of the pneumatic spot welding gun. The proportional valve is controlled by the welding timer in the Power unit. The included distribution block can be used for two additional non-regulated compressed air circuits. An analogue signal 0-10V, controls the proportional valve and the air pressure is in the range of 0-12 bar.

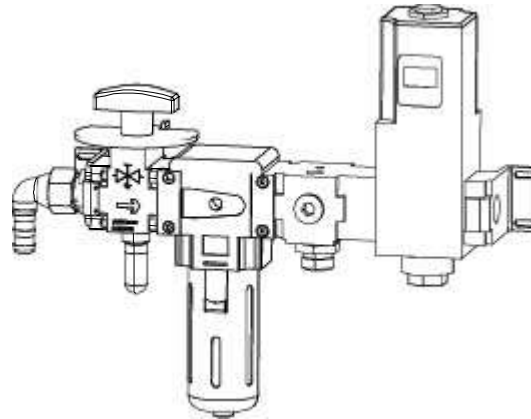

Figure 118 Air unit with Electric Proportional Valve.

Option	Type	Description
797-1	Cable to split box, 7 m	Offers floor cable of 7 m length for signals to the split box placed on the water and air unit. This cable is connected to the SpotWelding cabinet with a modular Harting and it ends with a quick connector at the split box.
797-2	Cable to split box, 15 m	Offers floor cable of 15 m length for the split box. See description of option 797-1.
797-3	Cable to split box, 22 m	Offers floor cable of 22 m length for the split box. See description of option 797-1.
797-4	Cable to split box, 30 m	Offers floor cable of 30 m length for the split box. See description of option 797-1.

2 SpotPack and DressPack

2.9.2 Interface description Water and Air unit

2.9.2 Interface description Water and Air unit

General

The interface towards the Water and Air unit is described in table below.

Type	Pcs	Specification
Connections for media		
Incoming water	1	Parker Pushlock 33482-8-8BK fitting for 1/2" hose ^a
Outgoing water	1	Parker Pushlock 33482-8-8BK fitting for 1/2" hose ¹
Incoming air	1	Parker Pushlock 33482-8-8BK fitting for 1/2" hose ¹
Extra air outlet	1	1/2" connection ^b

a. Connection to be made by customer.

b. Plugged at delivery (to be used for tip-dresser or other equipment). (Fitting 1/2" BSP 1,5).

General Technical data

Data	Description
Maximum water pressure	10 bar / 145 PSI
Maximum air pressure	16 bar / 230 PSI
Maximum pressure drop	0,35 bar at 6 liter/minute ^a
Water quality	Normal filtered industrial water quality
Air quality	

a. The pressure drop is measured under the following conditions:

Measuring point 1: Incoming water connection at water and air unit.

Measuring point 2: Outgoing water connection at water and air unit.

The water hoses (Proc 2 and Proc 3) are cross-connected at the end at axis 6 (the pressure drop is measured without any tool).

2.10 Connection kits

2.10.1 Options

Option 459-1, CP/CS, Proc 1 on base

R1. CP/CS and Proc 1 on base.

This option offers a kit with connectors. This must be assembled by the customer.

The kit contains:

- 1 Hose fittings (Parker Pushlock, (1/2", M22x1,5 Brass, 24 degree seal))
- Connector with:

1 pcs Hood Foundry (Harting)	HAN EMC / M 40
1 pcs Hinged frame (Harting)	Shell size 16
2 pcs Multicontact, female (Harting)	Type HD (25 pin)
1 pcs Multicontact, female (Harting)	Type EE (8 pin)
1 pcs Multicontact, female (Harting)	Type DD (12 pin)
10 pcs Female crimp contacts	For 1,5 mm ²
10 pcs Female crimp contacts	For 0,5 mm ²
10 pcs Female crimp contacts	For 1,0 mm ²
10 pcs Female crimp contacts	For 2,5 mm ²
12 pcs Female crimp contacts	For 0,14 – 0,37 mm ²
45 sockets	For 0,2 – 0,56 mm ²
Assembly Accessories to complete connector	
Assembly instruction	

Option 480-1, Weld, Proc 2-4 on base

R1. Weld and Proc 2-4 on base

This option offers a kit with weld connector and fittings. This must be assembled by the customer. The kit contains:

- 4 Hose fittings (Parker Pushlock, (1/2", M22x1,5 Brass, 24 degree seal))
- Weld connector with:

1 pcs Welding connector socket (MC)	3x35 mm ²
1 pcs Cable gland, plastic	Diameter 24-28 mm
Assembly Accessories to complete connector	
Assembly instruction	

2 SpotPack and DressPack

2.10.1 Options

Option 474-1, Pos switch on base

R1. SW1 and SW2/3 on base

This option offers a kit with two connectors. This must be assembled by the customer. The kit contains:

- Connector for position switch axis1 (SW 1) with:

1 pcs Socket connector (32p)	Souriau UTOW
1 pcs Adaptor	Used with form shrink
35 pcs Sockets Souriau UTOW	for 0,13-0,25 mm ²
Assembly Accessories to complete connector	
Assembly instruction	

- Connector for position switch axis 2/3 (SW2/3) with:

1 pcs Socket connector (32p)	Souriau UTOW, Rotated version (85 degrees)
1 pcs Adaptor	Used with form shrink
35 pcs Sockets Souriau UTOW	for 0,13-0,25 mm ²
Assembly Accessories to complete connector	
Assembly instruction	

Option 453-1, FB 7

R3. FB 7 on base

This option offers a kit with a connector. This must be assembled by the customer. The kit contains:

- Connector with:

1 pcs Multiple connector (pin)	Burndy
1 pcs Adaptor	8 pin
15 pcs Pin	for 0,13-0,25 mm ²
Assembly Accessories to complete connector	
Assembly instruction	

Option 458-1, CP/CS, Proc 1 axis 3

R2. CP/CS and Proc 1 on axis 2/3

This option offers a kit with connectors. This must be assembled by the customer. This option could also be used at axis 6 for IRB 6600ID.

The kit contains:

- 1 Hose fittings (Parker Pushlock, (1/2", M22x1,5 Brass, 24 degree seal))
- Connector with:

1 pcs Hood Foundry (Harting)	HAN EMC / M 40
1 pcs Hinged frame (Harting)	Shell size 16
2 pcs Multicontact, male (Harting)	Type HD (25 pin)
1 pcs Multicontact, male (Harting)	Type EE (8 pin)
1 pcs Multicontact, male (Harting)	Type DD (12 pin)
10 pcs Male crimp contacts	For 1,5 mm ²
10 pcs Male crimp contacts	For 0,5 mm ²
10 pcs Male crimp contacts	For 1,0 mm ²
10 pcs Male crimp contacts	For 2,5 mm ²
12 pcs Male crimp contacts	For 0,14 – 0,37 mm ²
45 pins	For 0,2 – 0,56 mm ²
Assembly Accessories to complete connector	
Assembly instruction	

Option 479-1, Weld, Proc 2-4 axis 3

R2. Weld and Proc 2-4 on axis 2/3

This option offers a kit with weld connector and fittings. This must be assembled by the customer. This option could also be used at axis 6 for IRB 6600ID.

The kit contains:

- 3 Hose fittings (Parker Pushlock, (1/2", M22x1,5 Brass, 24 degree seal))
- Weld connector with:

1 pcs Welding connector pin with flange (MC)	3x35 mm ² (25 mm ² pin)
1 pcs Cable gland, plastic	Diameter 24-28 mm
Assembly Accessories to complete connector	
Assembly instruction	

2 SpotPack and DressPack

2.10.1 Options

Option 452-1, Weld, Proc 1-4 axis 6

Weld and Proc 1-4 axis 6 on manipulator side

The process cable package from axis 3 to axis 6 (option 780-2-1 or option 781-1) ends with free end for media and for weld power cable¹. The option 452-1 offers a kit for connectors. This must be assembled by the customer when hoses and power cable has been cut to required length. The kit contains:

- 4 Hose fittings (Parker Pushlock, (1/2", M22x1,5 Brass, 24 degree seal))
- 1 Multi contact connector (Female) type including:

1 pc Welding connector socket incl. housing	3x35 mm ² (35 mm ² socket)
1 pc Cable gland	
1 pc End housing	
Assembly Accessories to complete connector	
Assembly instruction	

Option 543-1, CP/CS/CBus, Proc 1 axis 6

CP/CS/CBus, Proc 1 axis 6 on tool side

This kit offers a kit with connectors to be mounted at toolside of axis 6¹.

This must be assembled by the customer.

The kit contains:

- 1 Hose fitting (Parker Push lock (1/2", M22x1,5 Brass, 24 degree seal))
- Connector with:

1 pcs Hood Foundry (Harting)	HAN
1 pcs Hinged frame (Harting)	Shell size 10
1 pcs Multicontact, male (Harting)	Type HD (25 pin)
1 pcs Multicontact, male (Harting)	Type EE (8 pin)
1 pcs Multicontact, male (Harting)	Type DD (12 pin)
10 pcs Male crimp contacts	For 1,5 mm ²
10 pcs Male crimp contacts	For 0,5 mm ²
10 pcs Male crimp contacts	For 1,0 mm ²
10 pcs Male crimp contacts	For 2,5 mm ²
15 pcs Male crimp contacts	For 0,14 – 0,37 mm ²
30 pins	For 0,2 – 0,56 mm ²
Assembly Accessories to complete connector	
Assembly instruction	

1. Not with ID

3 Specification of Variants and Options

3.1 Introduction

3.1.1 General

The different variants and options for the IRB 6600 are described following sections. The same numbers are used here as in the Specification form. For controller options, see Product Specification IRC5 and for Controller software IRC5.

3.1.2 Manipulator

Variants

Option	IRB Type	Handling capacity (kg)/Reach (m)
435-22	6600	175/2.8
435-17	6600	225/2.55
435-16	6600	175/2.55
435-30	6650	125/3.2
435-19	6650	200/2.75
435-50	6650S	125/3.5
435-51	6650S	200/3.0
435-53	6600ID	185/2.55
435-55	6650ID	170/2.75

Manipulator color

Option	Description	Note
209-1	Standard	The manipulator is painted in ABB orange.
209-4 --192	RAL code	Colors according to RAL-codes.

Protection

Option	Description	Note
287-4	Standard	IP 67
287-3	Foundry	Robot adapted for foundry or other harsh environments. The robot has the FoundryPlus protection which means that the whole manipulator is steam washable. The excellent corrosion protection is obtained by a special coating. The connectors are designed for severe environment, and bearings, gears and other sensitive parts are highly protected.

3 Specification of Variants and Options

3.1.3 Equipment

3.1.3 Equipment

Option	Type	Description
213-1	Safety lamp	A safety lamp with an orange fixed light can be mounted on the manipulator. The lamp is active in MOTORS ON mode. The safety lamp is required on a UL/UR approved robot.
159-1	Fork lift device	Lifting device on the manipulator for fork-lift handling. Note. When Cooling Fan for axis 1 motor unit is used, this must be disassembled in order to use fork lift device.
37-1	Base plate	Can also be used for IRB 7600. See 1.3 Installation., for dimension drawing.
87-1	Cooling fan for axis 1 motor (IP 54)	Cannot be combined with Cooling fan for axis 2 motor option 88-1. For in use recommendations see 1.8 Cooling fan for axis 1-3 motor. Not for protection Foundry.
88-1	Cooling fan for axis 2 motor (IP 54)	For in use recommendations see 1.8 Cooling fan for axis 1-3 motor. Not for protection Foundry.
89-1	Cooling fan for axis 3 motor (IP 54)	For in use recommendations see 1.8 Cooling fan for axis 1-3 motor. Not for protection Foundry.
430-1	Upper arm covers	See Figure 119. Included in protection Foundry

Upper arm covers

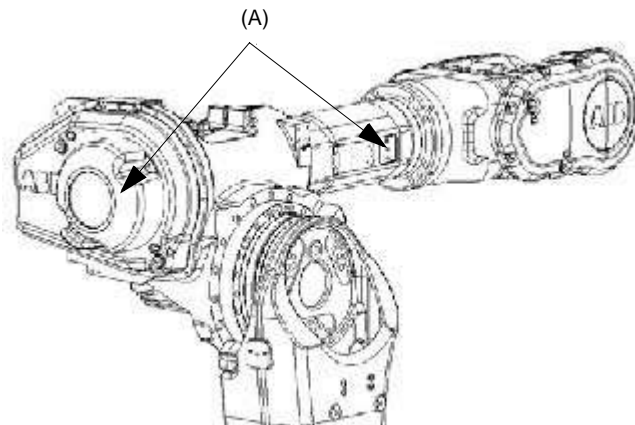

Figure 119 Upper arm covers.

Pos	Description
A	Option 430-1



The Insulated tool flange option can be ordered in combination with the Absolute Accuracy option, and the robot will then be factory calibrated.

When the Insulated tool flange is mounted after the robot delivery, the robot must be recalibrated for absolute accuracy.

Insulated tool flange

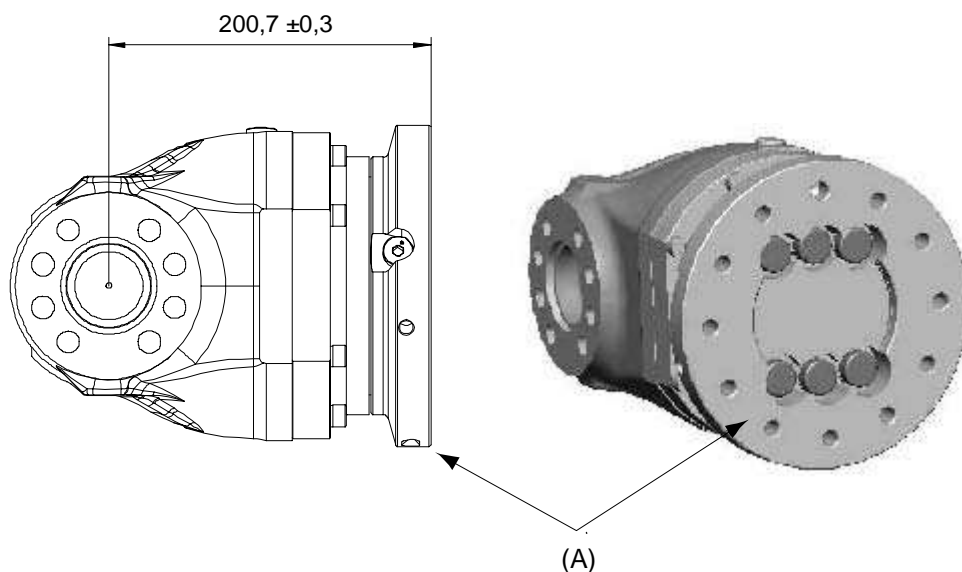

Figure 120 Insulated tool flange (dimensions in mm).

Option	Type	Description
184-1	Insulated tool flange (A)	<p>The electrically insulated tool flange, according to European Standard EN 60204-1, withstands dangerous voltage (in case of an electrical fault in the spot welding equipment mounted on the Insulated tool flange) of 500V DC during 30 seconds in non water applications without passing it further to the electronics in the manipulator and the controller.</p> <p>Not available together with Protection Foundry, option 287-4 and IRB 6600ID/6650ID options 435-53,435-55.</p> <p>Connection holes and all dimensions are the same as for the standard tool flange except for the distance from c/c 5th axis to the end surface of the Insulated tool flange. The distance is 0,7 mm longer compared to the standard tool flange, see Figure 120. The countersunked holes for the fastening bolts to the gear box are larger, and the bolts are insulated from the tool flange, see Figure 120.</p>

3 Specification of Variants and Options

3.1.3 Equipment

Chip protection

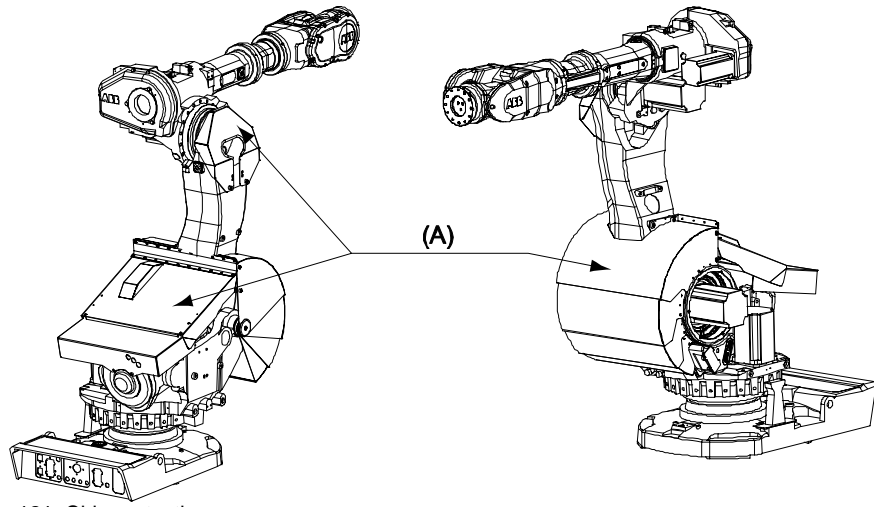

Figure 121 Chip protection.

Option	Type	Description
536-1	Chip protection (A)	The mechanical protection prevents chips created at applications as for instance, deburring, sawing and milling to be accumulated on the robot and secure its movable functionality. Only together with protection Foundry. See Figure 121.

Base Spacers

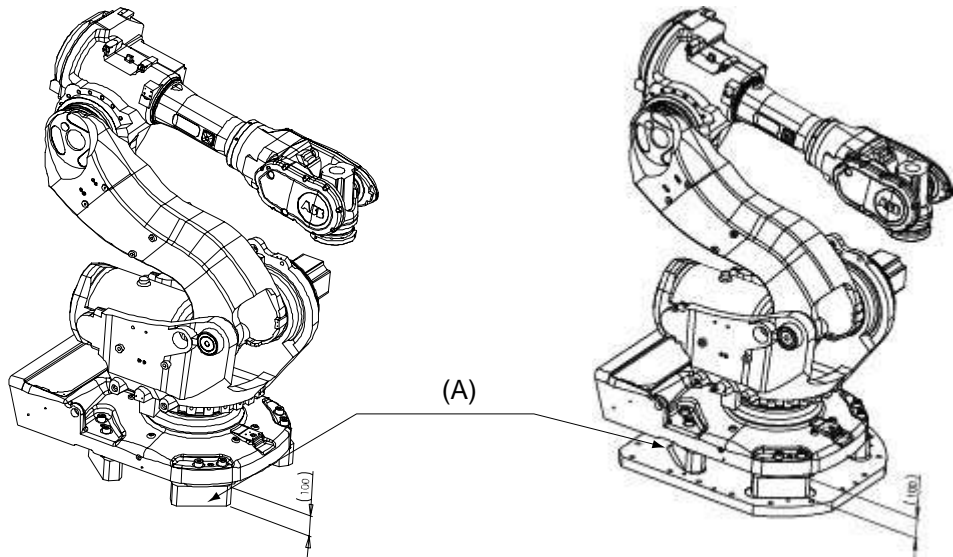

Figure 122 Base spacers.

Option	Type	Description
571-1	Base Spacers (A)	Four spacers to raise the robot 100mm from the floor or the base plate. See Figure 122.

3.1.4 Position Switches

General

Position switches indicating the position of the three main axes. Rails with separate adjustable carms are attached to the manipulator. The carms, which have to be adapted to the switch function by the user, can be mounted in any position in the working range for each switch. No machining operation of the carms is necessary for the adaptation, simple hand tools can be used.

Function

For axis 1, there are three redundant position zones available, each with two independent switches and carms. For axes 2 and 3, two channels position zones are available, each with two independent switches and carms.

Each position zone consists of two switches mechanically operated by separate carms. Each switch has one normally open and one normally closed contact. The design and components fulfill the demands to be used as safety switches. These options may require external safety arrangements, e.g. light curtains, photocells or contact mats.

The switches can be connected either to the manipulator base (R1.SW1 and R1.SW2/3, see Figure 75), or to the controller. In the controller the signals are connected to screw terminal XT8 Phoenix rmsTB 2.5/12-ST-5.08. Switch type Balluff Multiple position switches BNS, according to EN 60947-5-1 and EN 60947-5-2.

Position switches

Option	Type	Description
25-3	Position switches axis 1	Three redundant position zones are available, each with two independent switches and carms. Two plus one zone.
30-1	Position switches axis 2	Two redundant position zones are available, one with two independent switches and carms, and the other with one independent switch and cam. Not for protection foundry, (opt. 287-3).
33-1	Position switches axis 3	Two redundant position zones are available, one with two independent switches and carms, and the other with one independent switch and cam. Not for protection foundry, (opt. 287-3).

Connection to

Option	Type	Description
271-2	Manipulator	Connection on the manipulator base with one/two Souriau 32-pin connector.

3 Specification of Variants and Options

3.1.4 Position Switches

Option	Type	Description
271-1	Cabinet	Connection inside the cabinet wall. See Product Specification IRC5. Position switch cables are included.

Working Range Limit

To increase the safety of the robot, the working range of axes 1, 2 and 3 can be restricted by extra mechanical stops.

Option	Type	Description
29-2	Axis 1, 7,5 degrees	Four stops, two which allow the working range to be restricted in increments of 15° and two stops of 7,5°.
29-1	Axis 1, 15 degrees	Two stops which allow the working range to be restricted in increments of 15°.
32-1	Axis 2	Six stops which allow the working range to be restricted in increments of 15° at both end positions. Each stop decreases the motion by 15°.
34-1	Axis 3	Six stops which allow the working range to be restricted in increments of 20° at both end positions. Each stop decreases the motion by 20°.

Extended work range

Option	Type	Description
561-1	Extended work range axis 1	To extend the working range on Axis 1 from $\pm 180^\circ$ to $\pm 220^\circ$. When the option is used the mechanical stop shall be disassembled. Position switches axis 1, opt. 25-3, are required.

Warranty

Option	Type	Description
438-1	Standard Warranty	Standard warranty is 18 months (1 1/2 years)
438-2	Standard + 12 months	18 + 12 months (2 1/2 years)
438-4	Standard + 18 months	18 + 18 months (3 years)
438-5	Standard + 24 months	18 + 24 months (3 1/2 years)
438-6	Standard + 6 months	18 + 6 months (2 years)



DressPack options 778-1, 778-2, 780-1, 780-2 and 781-1 are not included in the warranty options.

3.1.5 Floor cables

General

Additional floor cables for SpotPack options, see chapter 3.1.7 DressPack Floor.

Manipulator cable length

Option	Lengths
210-2	7 m
210-3	15 m
210-4	22 m
210-5	30 m

Cable length Position switches Axis 1

Option	Lengths
273-1	7 m
273-2	15 m
273-3	22 m
273-4	30 m

Cable length Position switches Axis 2 and 3

Option	Lengths
274-1	7 m
274-2	15 m
274-3	22 m
274-4	30 m

3 Specification of Variants and Options

3.1.6 Process DressPack

3.1.6 Process DressPack

Connection to

Option	Connection to	Description
16-1	Cabinet	The signals CP/CS are connected to 12-pole screw terminals, Phoenix rmsTB 2.5/12-ST-5.08, in the controller. The cable between R1.CP/CS and the controller is supplied. For information about the limited number of signals available, see 2.3 Type H. to 2.6 Type Se.
16-2	Manipulator	The signals are connected directly to the manipulator base to one heavy duty industrial housing with a Harting modular connector R1.CP/CS see Figure 75. The cables from the manipulator base are not supplied.

Communication

Option	Type	Description
455-1	Parallel communication	Includes customer power CP, customer signals CS.
455-4	Parallel and bus communication	Includes CP, customer signals and CAN/DeviceNet or Profibus or Interbus for process cable package.

3.1.7 DressPack Floor

Connection to Parallel/CAN DeviceNet/Interbus/Profibus

Following information specifies the cable length for Parallel/CANDeviceNet/Interbus/Profibus for connection to cabinet.

Option	Lengths
94-1/90-2/91-2/92-2	7 m
94-2/90-3/91-3/92-3	15 m
94-3/90-4/91-4/92-4	22 m
94-4/90-5/91-5/92-5	30 m

Connection to first & second drive

Following information specifies the cable length for Connection to first drive/ Connection to first & second drive. For further information see chapter 1.9 Servo Gun.

Option	Lengths
786-1/787-1	7 m
786-2/787-2	15 m
786-3/787-3	22 m
786-4/787-4	30 m

3.1.8 DressPack Lower and Upper arm

Material Handling



For more information about the process cable packages, see 2.2 DressPack. and 2.3 Type H.

Option	Description	Note
778-1	Material Handling from base to axis 2/3	Available in "Silver line" (option 798-1) and "Orange line" (option 798-2) routing. Includes signals and one air hose.
780-2	Material Handling from axis 2/3 to axis 6 extended routing	Available in "Silver line" and "Orange line" routing. Includes signals and one air hose.
780-1	Material Handling from axis 2/3 to axis 6 internal routing	Available in "Orange line" routing. Includes signals and one air hose. Only for IRB 6600ID/6650ID (Options 435-5 and 435-55).

Spot Welding



For more information see Chapters 2.2 DressPack., 2.4 Type S. and 2.6 Type Se.

Option	Description	Note
778-2	SpotWelding from base to axis 2/3	Available in "Silver line" (Option 798-1) and "Orange line" (Option 798-2) routing. Includes signals, weld power cable, one air hose and three media hoses.
780-2	SpotWelding from axis 2/3 to axis 6	Available in "Silver line" and "Orange line" routing. Includes signals, weld power cable, one air hose and three media hoses.
781-1	SpotWelding from base to axis 6	Available in "Orange line" routing only. Includes signals, weld power cable, one air hose and three media hoses without change-over connection between lower and upper arm.
780-1	SpotWelding from axis 2/3 to axis 6 internal routing	Available in "Orange line" routing. Includes signals, weld power cable, one air hose and three media hoses. Only for IRB 6600ID/6650ID (Options 435-53 and 435-55)

DressPack line

Option	Description	Note
798-1	Silver line	Routing with connection point at axis 3.
798-2	Orange line	Routing with connection point at axis 2/3 or without connection point (Option 781-1).

3 Specification of Variants and Options

3.1.9 Connection Kits

3.1.9 Connection Kits

General

The connectors fit to the connectors at the manipulator base, axis 2/3 and 6 respectively.

Content

The kit consists of connectors, pins and sockets. For technical description, see 2.10 Connection kits.

Option	Type	Description
459-1	R1.CP/CS and PROC1	For the Customer Power/Customer Signal connector and one Process connector on the manipulator base. Sockets for bus communication are included.
480-1	R1.WELD and PROC2-4	For the Weld connector and three Process connectors on the manipulator base.
474-1	R1.SW1 and SW2/3	For the position switch axis 1 connector and the position axis 2/3 connector on the manipulator base.
453-1	R3.FB7	For the 7-axis connector on the manipulator base.
458-1	R2.CP/CS and PROC1	For the Customer Power/Customer Signal connector and one Process connector at axis 2/3. Pins for bus communication are included.
479-1	R2.WELD and PROC2-4	For the Weld connector and three Process connectors at axis 2/3.
452-1	WELD and PROC1-4 axis 6	Weld connector and four Process connectors at axis 6, the manipulator side.
543-1	CP/CS/BUS, PROC1 axis 6	Connector for customer power/customer signal/customer bus at axis 6 tool side.

3.1.10 Servo Gun

Content

For technical description see chapter 1.9 Servo Gun.

Option	Lengths
785-1	For robot handled Servo Gun.
785-2	For robot handled Servo Gun in combination with servo driven Track Motion.
785-3	For robot handled Servo Gun in combination with Stationary Servo Gun.
785-4	For Stationary Servo Gun in combination with servo driven Track Motion.
785-5	For Stationary Servo Gun.
785-6	For Twin Stationary Servo Gun.

3 Specification of Variants and Options

3.1.11 SpotPack Floor Cables

3.1.11 SpotPack Floor Cables

Weld Power Cable

Following information specifies the cable length for the Weld Power cable, from the SpotWelding process cabinet to the manipulator base.

Option	Lengths
791-1	7 m
791-2	15 m

Process Cable to Stationary Gun

Following information specifies the cable length for the Process Cable to the Stationary Gun, from the SpotWelding process cabinet to the Stationary Gun.

Option	Lengths
809-1	7 m
809-2	15 m
809-3	22 m
809-4	30 m

3.1.12 SpotPack Equipment

Process Cabinet

Option	Type	Description
768-1	Empty cabinet small	
768-3	SpotWelding smal	

Weld Timer capacity

Option	Type	Description
782-1	Bosch Basic AC S/SE	AC Welding Basic capacity
782-2	Bosch Basic AC HS/HSE	AC Welding Basic capacity
782-3	Bosch Extended AC S/SE	AC Welding Extended capacity
782-4	Bosch Extended AC HS/HSE	AC Welding Extended capacity
782-5	Medar Extended AC S/SE	AC Welding Extended capacity
782-6	Medar Extended AC HS/HSE	AC Welding Extended capacity
782-7	Bosch Basic MFDC S/SE	MFDC Welding Basic capacity
782-8	Bosch Basic MFDC HS/HSE	MFDC Welding Basic capacity
782-9	Medar Basic MFDC S/SE	MFDC Welding Basic capacity
782-10	Medar Basic MFDC HS/HSE	MFDC Welding Basic capacity

Other Equipment

Option	Type	Description
788-1	Forced Air Cooling	
789-1	Earth Fault Protection Unit	
790-1	Contact for Weld Power	

3 Specification of Variants and Options

3.1.13 Documentation

3.1.13 Documentation

CD User Documentation

Option	Type	Description
808-1	Documentation on CD	See Product Specification Robot User Documentation

Printed User Documentation

Option	Type	Description
428-1	English documentation	See Product Specification Robot User Documentation
358-1	Swedish documentation	See Product Specification Robot User Documentation
165-1	German documentation	See Product Specification Robot User Documentation
162-1	French documentation	See Product Specification Robot User Documentation
336-1	Spanish documentation	See Product Specification Robot User Documentation
97-1	Danish documentation	See Product Specification Robot User Documentation
195-1	Italian documentation	See Product Specification Robot User Documentation
234-1	Dutch documentation	See Product Specification Robot User Documentation
270-1	Portuguese documentation	See Product Specification Robot User Documentation
666-1	Chinese documentation	See Product Specification Robot User Documentation
667-1	Korean documentation	See Product Specification Robot User Documentation
668-1	Japanese documentation	See Product Specification Robot User Documentation
669-1	Czech documentation	See Product Specification Robot User Documentation
670-1	Finnish documentation	See Product Specification Robot User Documentation

4 Accessories

General

There is a range of tools and equipment available, specially designed for the robot.

Basic software and software options for robot and PC

For more information, see Product Specification IRC5, and for Controller software IRC5.

Robot Peripherals

- Track Motion
- Motor Units

A

accessories, 197
Active Brake System, 11

C

Collision detection, 12
colours, 183
cooling device, 7

E

Electronically Stabilised Path, 12
emergency stop, 14
enabling device, 14
equipment
 mounting, 46
 permitted extra load, 46

F

fire safety, 15
fork lift device, 184

H

Harting, 107
Harting Connector - External routing, 94, 121, 154
Harting connector - Internal routing, 95, 155
Harting connector/hoses Internal routing, 139
hold-to-run control, 15
hole configuration, 19
holes for mounting extra equipment, 48
humidity, 17

I

installation, 16
Internal Safety Concept, 14

L

lifting device, 184
limit switches, 13, 16, 187
load, 16, 18
load diagrams, 29

M

maintenance, 54
manipulator colour, 183
mechanical interface, 51, 52, 53
motion, 55
mounting
 extra equipment, 46
 robot, 18
mounting flange, 51, 52, 53

N

noise level, 7

O

operating requirements, 17
options, 183
overspeed protection, 12

P

Passive Safety System, 13
payload, 16
position switches, 13, 16, 187
protection, 183
protection standards, 17

R

range of movement, 55
reduced speed, 14
Robot Gun, 66
Robot Gun and Track Motion, 70
Robot Peripherals, 197
robot tool flange, 51, 52, 53
robot versions, 6

S

safeguarded space stop, 15
 delayed, 15
safety, 10
Safety category 3, 14
safety lamp, 15, 184
Self Tuning Performance, 11
service, 54
Service Information System, 10
space requirements, 7
standards, 10
Stationary and Robot Gun, 67
Stationary Gun, 65
Stationary Gun and Track Motion, 69
structure, 5

T

temperature, 17
troubleshooting, 54
Twin Stationary Guns, 68

V

variants, 183

W

working space
 restricting, 12, 16, 188

Z

zone switches, 13



ABB Automation Technologies AB
Robotics
S-721 68 VÄSTERÅS
SWEDEN
Telephone: +46 (0) 21 344000
Telefax: +46 (0) 21 132592

3HAC 023933-001, Revision 1, en