

right hand thread
single start
720° turn
pitch: 3,175mm

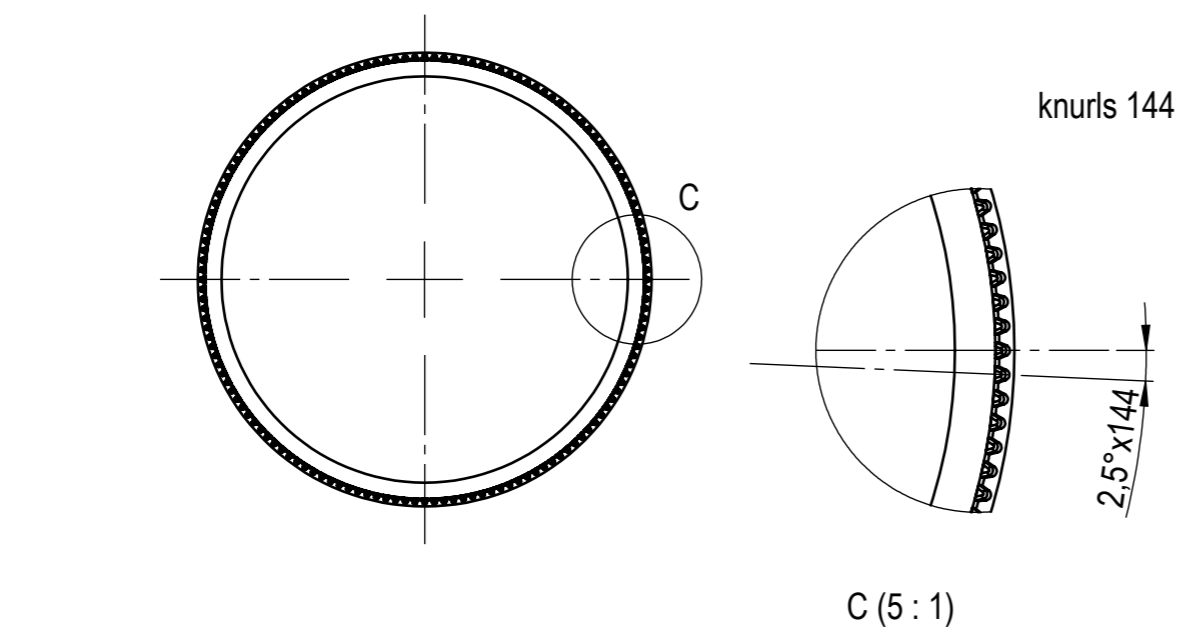
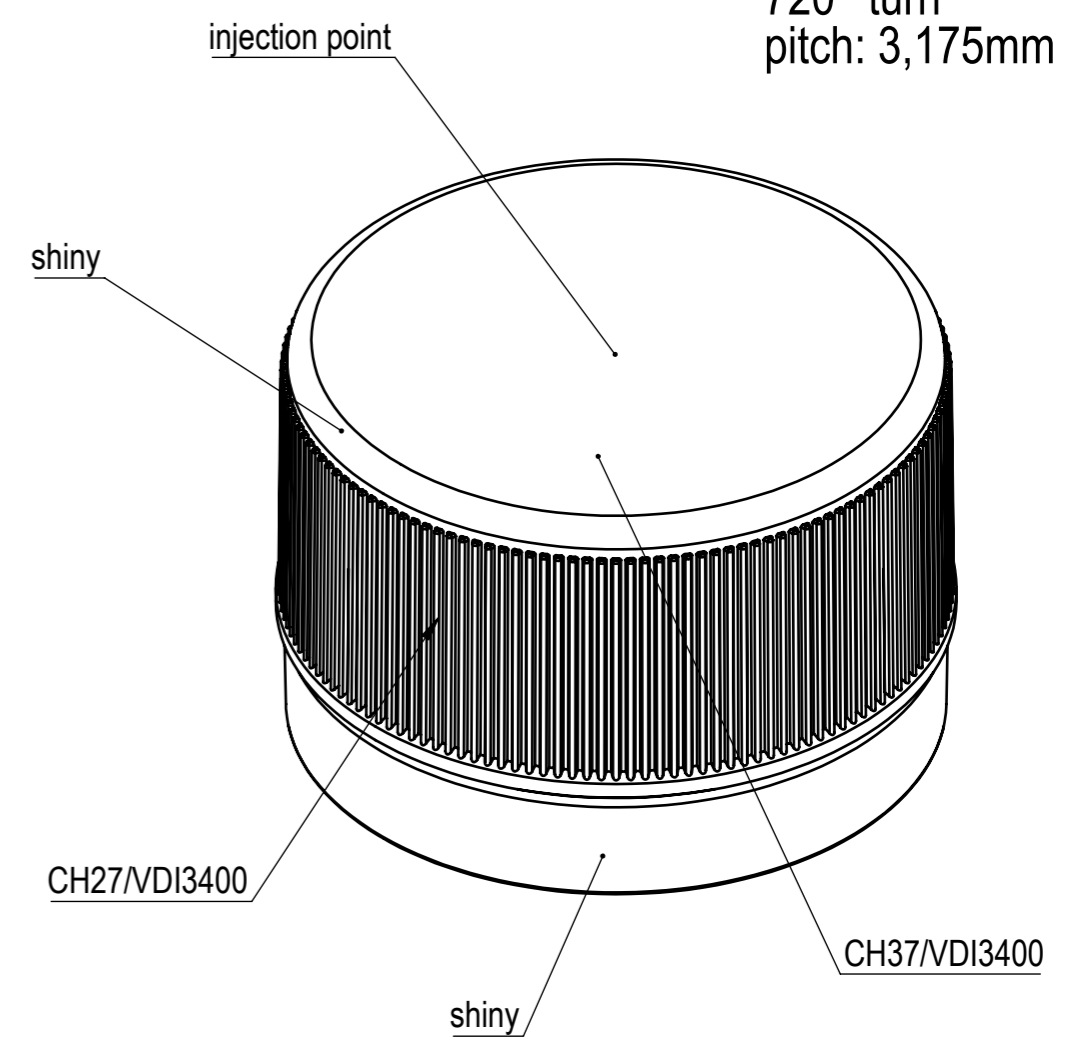
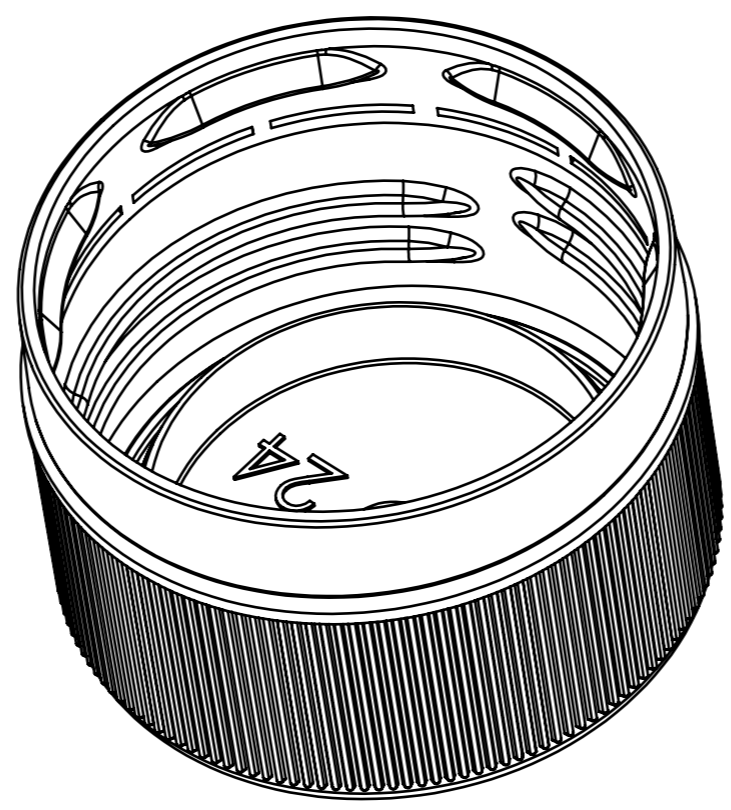
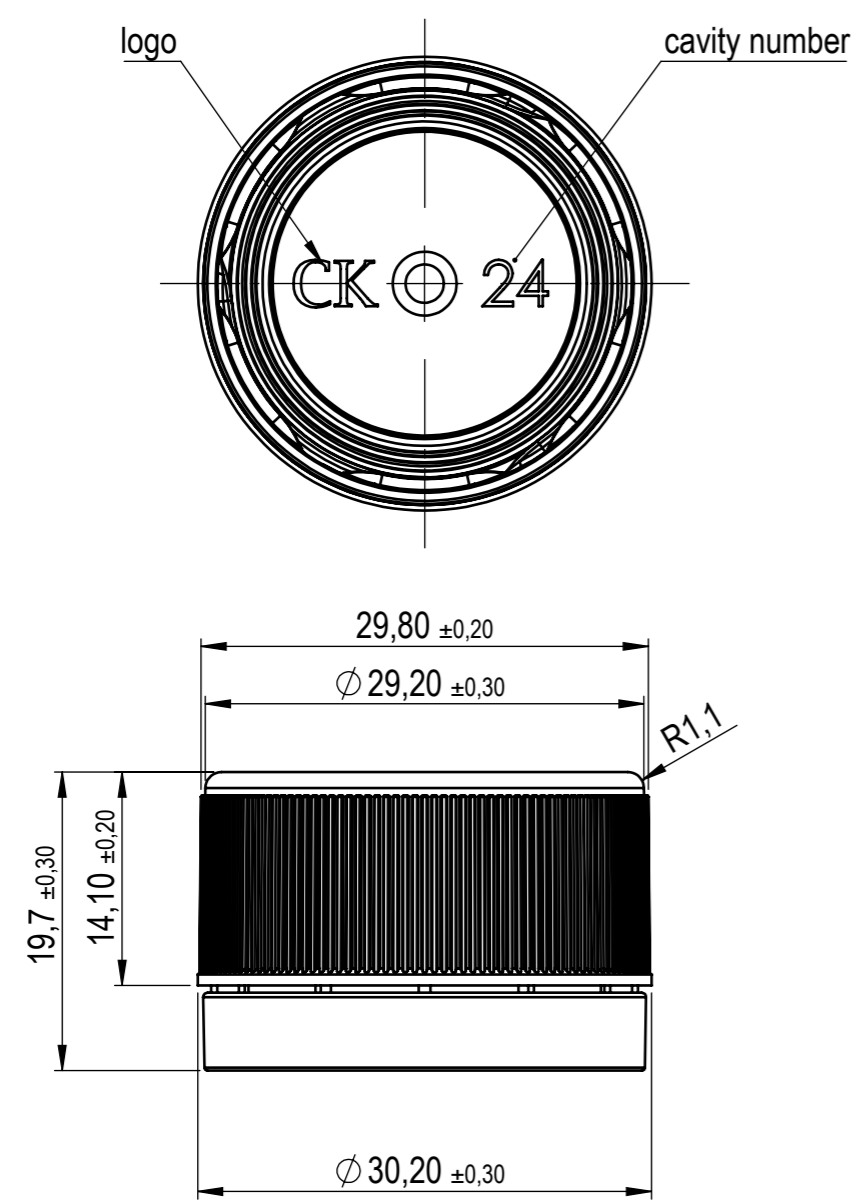

weight 2,5g +0,1
material HDPE

7,0g CO2/l

Masse ohne Toleranzangabe ->	Dezimalstellen	0	1	2	3				
Masse ohne Toleranzangabe ->	Toleranzfeld	±0.5	±0.3	±0.1	±0.05				
A3									
						1		KH	23.04.2020
Index	Änderung:	Name		Datum		Index	Änderung:	Name	Datum
Massstab:		Name		Datum					
2:1		Gez.: K. Halper		21.07.2015					
		Gepr.:							
		Ersatz für:							
		Ersetzt d.:				Für diese Zeichnung behalten wir uns alle Rechte vor.			
Benennung: SWZ 24-fach PCO 1810						Zeichnungsnummer:		Rev.	
						WZ_18_022		1	